

**Automobile Racing Club
of
America, LLC**

JOHN & MILDRED MARCUM*
Founders

JAMES C. FRANCE
Chairman of the Board and Chief Executive Officer

RON DRAGER
ARCA President

JOSEPH DENNEWITZ
Managing Director, Weekly and Touring Series

JESSE HARRIS
Managing Director, Partnership Sales and Marketing

GRAYLING CALL
Senior Director, Competition & Operations

JOE WELLS
Manager, Competition Administration

MIKE HEWER
Manager, Logistics and Event Operations

CHRIS A. WRIGHT
Director, ARCA East / West Series

BOBBY THOMSEN
Technical Services Director

JAKE JACOBS
Technical Director, ARCA East / West Series

TONY GLOVER
Technical Director, Touring Series

LES WESTERFIELD
Technical Coordinator, Touring Series

SHALENE WILLIAMS
Manager Accounting & Billing

DAN STUART
Director, Partnership Marketing

TYLER REAMER
Manager, Member & Employee Services

JACOB STOTZ
Senior Manager, Marketing Operations & Events

CHARLIE KRALL
Communications Manager

*Deceased

Copyright 1969 through 2024 by
Automobile Racing Club of America, LLC and
National Association for Stock Car Auto Racing, LLC
All rights reserved. Reproduction or redistribution in
any form without permission is strictly prohibited.

Post Office Box 2875
Daytona Beach, FL. 32120-2875

OFFICIALS

BOB ABITZ
ADRIA ALMAGER
ROCKY ANDERSON
DENIS BAGSBY
STEVE BINGOFF
RANDAL BRACKETT
BUDDY BRUCE
RANDY BURKE
SCOTT CAMERON
JOSE CONTRERAS
TOM CUMBOW
DOMINIC DILELLO
DON DOOLIN
NEAL EFIRD
DENISE ENGLE
MARK ENGLE
ROBBIE FALLIN
PAUL FITZGERALD
TERRY FRANCIS
LIZ FREDRICKSON
RICK GABEL
GEORGE GEIS
NICK GUIRUKIS
DONALD HAMILTON
MARK HONKOMP
DALE INGLE
THERESA INGLE
CRAIG JOHNSON
CASEY JUSTICE
STUART KOESTERER

LINDA KRIEG
JAY KRIEG
BOB LANGLEY
BECKY MCBRIDE
KYLE MCGOWAN
DEBBIE MEIER
HARVEY MORRIS
BRIAN MUNDIE
TONYA NEVIL
KENNY NEWBERRY
GARRY NEWBURY
EDWARD OWENS
JOHN PATTISON
KATHY PRESTON
TODD PRESTON
CELESTE PUTT
JENNIFER READY
THOMAS RUHL
ROBERT SANDERS
KEVIN STEPINSKI
WILLIE STILWELL
SCOTT STOVALL
TRINA STOVALL
MARK TURNER
MIKE VENTRESCA
DAVID WACHTER
CHRISTINE WALKER
JIMMIE WALKER
CHUCK WELCH
MARK WENDELL

TABLE OF CONTENTS

	Section	Page
The ARCA Rules.....	1	6
Membership.....	2	7
Licenses.....	3	9
Injury Reports.....	4	11
Safety.....	5	11
Entries.....	6	12
Approved Pit Support Vehicle Usage.....	7	13
Inspections & Eligibility.....	8	13
Event Procedure.....	9	16
Event Procedure (Flag Rules).....	10	24
Timing and Scoring.....	11	27
Violations and Disciplinary Action.....	12	27
Protests.....	13	35
Appeals.....	14	36
Final Appeals Officer.....	15	36
Prize Money.....	16	37
Points and Point Funds.....	17	37
ARCA Substance Abuse Policy.....	18	39
ARCA Menards Series Specifications.....	20C	43
Construction Guidelines (Rear Pages).....	--	123
Vehicle Requirements Index.....	--	154

PREFACE

An ARCA-sanctioned Event is a competitive stock car racing Event which is intended to be conducted and officiated in accordance with this Rule Book. This Rule Book may be amended from time to time. Special rules may be published by ARCA specifically for the Event and any applicable agreements to which ARCA is a party may also apply. The ARCA Rule Book is designed to provide for the orderly conduct of ARCA-sanctioned Events. Ultimately, the solution for unauthorized or improper officiating lies not in individual challenges seeking to undo what has been done, but rather in pressure brought upon the Officials in charge by drivers, owners, fans, and even ARCA to improve the caliber of Race supervision. It is the responsibility of each Member to address any complaint he/she might have regarding officiating to ARCA management.

It is ultimately the obligation of each participant to ensure that his/her conduct and equipment comply with all applicable ARCA Rules, as they may be amended from time to time. EXPRESSED OR IMPLIED WARRANTY OF SAFETY SHALL NOT RESULT FROM PUBLICATION OF, OR COMPLIANCE WITH, THESE RULES. They are intended as a guide for the conduct of stock car racing and are in no way a guarantee against injury or death to participants, spectators, or others.

**Intellectual Property
Owned By
National Association for
Stock Car Auto Racing, LLC.**

TRADEMARKS / SERVICEMARKS

NASCAR®, the NASCAR logo, Air Titan®, NASCAR Air Titan®, and all related slogans, logos and trade dress are trademarks of the National Association for Stock Car Auto Racing, LLC.

U.S. PATENTS

<u>PATENT NAME</u>	<u>U.S. PATENT NUMBER / APPLICATION NUMBER</u>
(1) SYSTEM AND APPARATUS FOR INCREASING DOWNWARD FORCE ON THE AFT END OF A MOTOR VEHICLE	11,390,335
(2) APPARATUSES, SYSTEMS, AND METHODS FOR CLEARING A SURFACE USING PRESSURIZED AIR	10,024,010
(3) APPARATUSES, SYSTEMS, AND METHODS FOR CLEARING A SURFACE USING AIR	10,024,009
(4) APPARATUSES, SYSTEMS, AND METHODS FOR CLEARING A SURFACE USING PRESSURIZED AIR	9,388,542
(5) METHOD OF CONDUCTING A RACING SERIES	7,207,568
(6) ROAD SURFACE CLEARING APPARATUS	D740,860
(7) RETAINING SYSTEM	8,485,482
(8) RETAINING SHOE	D666,134
(9) RETAINER COUPLER	D656,883

The above noted trademarks, and patents, among others, are the exclusive property of National Association for Stock Car Auto Racing, LLC. Unauthorized use of any intellectual property without the express written permission of National Association for Stock Car Auto Racing, LLC in any manner may be a violation of state or federal law. National Association for Stock Car Auto Racing, LLC will pursue its appropriate legal remedies to protect its statutory (and common law) rights in and to its intellectual property.

ARCA, as the licensee of NASCAR hereby grants to each ARCA Member a revocable, royalty-free license for 2024 to make and use the objects and methods embodied in the patents and patent applications listed above which are numbered (7) through (9) only for the sole purpose of competing in ARCA-sanctioned Events, unless otherwise approved in writing by ARCA. In addition, ARCA hereby grants each ARCA Member a revocable, royalty-free license for 2024 to sell to other ARCA Members only the objects and methods embodied in the patents and patent applications listed above which are numbered (7) through (9) only for the sole purpose of competing in ARCA-sanctioned Events, unless otherwise approved in writing by ARCA.

SECTION 1 - THE ARCA RULES

1-1 Effective Date

A. The ARCA Rules, including any Amendments thereto, are effective upon the Date of Issuance by ARCA, regardless of when an ARCA Member receives actual notice.

B. "Date of issuance" of the ARCA Rules, or any amendments thereto, is the earliest of:

1. Electronic posting date of an ARCA Bulletin on the ARCA Members website (arcaracing.com);
2. Mailing, emailing, or other timely distribution of notice to Members of the ARCA Bulletin;
3. ARCA's written or verbal announcement or distribution of an ARCA Bulletin to the industry of an immediate change (i.e. driver meeting announcement, etc.).

1-2 Amendment

A. The ARCA Rules may be amended by issuance of an ARCA Bulletin issued by ARCA.

B. Amendments to the ARCA Rules are effective immediately upon the Date of Issuance by ARCA, regardless of when an ARCA Member receives actual notice, unless otherwise set forth in the ARCA Bulletin.

C. Amendments to the ARCA Rules will be published by ARCA through official ARCA Bulletins made available on the ARCA Members website (arcaracing.com) or as otherwise announced or distributed by ARCA to its Members. Upon publication of the ARCA Bulletin, amendments to the ARCA Rules for the current season will be reflected in "redline" format to clearly distinguish the change from the original version.

1-3 Applicability

ARCA issues the Rule Book, which includes in the title reference to the ARCA Menards Series. The ARCA Rules within the Rule Book are applicable to all divisions of the ARCA Menards Series.

1-4 Interpretation and Application

A. If there is a disagreement or dispute regarding the meaning or application of the ARCA Rules, the interpretation and application by ARCA shall prevail.

B. Notwithstanding the foregoing or any other provision in the Rule Book, ARCA Supervisory Officials may review, adjust, modify and/or supersede an interpretation or application of the ARCA Rules when the ARCA Supervisory Officials deem such action to be appropriate.

C. Any and all print or paper copies of the ARCA Rules represent the status of the ARCA Rules as of the print date only. ARCA does not guarantee or represent that any print or paper copy of the ARCA Rules is correct or up to date. It is the responsibility of each ARCA Member to remain informed of and operate in accordance with the current version of the ARCA Rules at all times, as may be amended from time to time. Please contact the Series Director with any questions or concerns on the current status of the ARCA Rules.

1-5 Finality of Interpretation and Application

A. The interpretation and application of the ARCA Rules by the ARCA Officials at the Event, or by ARCA Supervisory Officials, pursuant to sub-section 1-4 Interpretation and Application, shall be final and non-appealable, except as provided in the following Rule Book Sections:

1. Section 12 Violations and Disciplinary Action;
2. Section 14 Appeals
3. Section 15 Final Appeal

B. In order to promote stock car racing, to achieve prompt finality in competition results, and in consideration of receiving the numerous benefits available to them, ALL MEMBERS, INCLUDING COMPETITORS AND OFFICIALS, EXPRESSLY AGREE THAT DETERMINATIONS BY ARCA OFFICIALS (WHETHER LOCAL, REGIONAL OR NATIONAL) (AND ARCA SUPERVISORY OFFICIALS WHEN MADE) AS TO THE APPLICATION AND INTERPRETATION OF THE ARCA RULES ARE NON-LITIGABLE, AND THEY COVENANT THAT THEY WILL NOT INITIATE OR MAINTAIN LITIGATION OF ANY KIND AGAINST ARCA OR ANYONE ACTING ON BEHALF OF ARCA, WITH RESPECT TO SUCH DETERMINATIONS OR TO RECOVER DAMAGES OR TO SEEK ANY OTHER KIND OF RELIEF AS A RESULT OF SUCH DETERMINATIONS, UNLESS THE ARCA OFFICIALS OR SUPERVISORY OFFICIALS MADE SUCH DETERMINATIONS FOR NO PURPOSE OTHER THAN A BAD-FAITH INTENT TO HARM OR CAUSE ECONOMIC LOSS TO THE MEMBER, COMPETITOR OR OFFICIAL. IF A MEMBER, COMPETITOR OR OFFICIAL INITIATES OR MAINTAINS LITIGATION IN VIOLATION OF THIS COVENANT, THAT MEMBER, COMPETITOR OR OFFICIAL AGREES TO REIMBURSE ARCA

FOR THE COSTS OF SUCH LITIGATION, INCLUDING ATTORNEYS' FEES. EACH MEMBER, COMPETITOR OR OFFICIAL FURTHER COVENANTS THAT IN ANY LITIGATION BROUGHT AGAINST ARCA FOR ANY REASON, IF THE LITIGATION IS NOT DISMISSED PURSUANT TO THIS COVENANT, THE MATTER WILL BE TRIED BEFORE A JUDGE OF COMPETENT JURISDICTION AND HEREBY WAIVES ANY RIGHT TO TRIAL BY JURY IN SUCH ACTION. ARCA RESERVES THE RIGHT TO TAKE ANY OTHER ACTION HEREUNDER, INCLUDING SUSPENSION OR TERMINATION OF MEMBERSHIP, FOR VIOLATION OF THE COVENANT NOT TO SUE.

1-6 Principal Rule of Interpretation and Application

A. The ARCA Rules are intended to ensure that ARCA-sanctioned Events are conducted in a manner that is as fair as possible for all Competitors, consistent with prompt finality in competition results.

B. On occasion, circumstances will be presented that are either unforeseen or are otherwise extraordinary, in which strict application of the ARCA Rules may not achieve this goal. In such rare circumstances, the ARCA Officials, as a practical matter, may make a determination regarding the conduct of an Event, the eligibility of a Competitor, or similar matters that are not contemplated by or are inconsistent with the ARCA Rules, in order to achieve this goal.

C. From time to time, in particular rules, Official Entry Blanks, Bulletins and elsewhere, ARCA may use the term "EIRI" – meaning "Except in Rare Instances" – to indicate the likelihood that such a determination may be made.

D. ARCA, however, may make such a determination even if "EIRI" has not been included in a particular rule, Official Entry Blank, Bulletin or otherwise. Such determinations are reviewable by ARCA Supervisory Officials pursuant to sub-section 1-4 Interpretation and Application. All such determinations are subject to sub-section 1-5 Finality of Interpretation and Application.

1-7 Special Rules

Special rules may be made by the Supervisory Officials for an Event. Such special rules shall apply to the conduct of that Event if they are issued or announced prior to or during the Event by means of a Bulletin, newsletter, fax, electronic or internet posting or Pre-Race meeting.

SECTION 2 - MEMBERSHIP

2-1 Application Process

A. Application/renewal forms for ARCA membership may be obtained from ARCA Headquarters and are also available at arcaracing.com for certain membership categories.

B. Upon completion, membership application/renewal forms must be submitted to ARCA Headquarters, which is the only ARCA office authorized to approve and issue such ARCA memberships.

C. Membership application/renewal forms must be fully executed, signed by the applicant, and accompanied by the requisite fee(s).

D. Membership application/renewal forms will not be processed/issued until all appropriate forms are received. **Electronic signatures are not acceptable.**

E. The receipt of an ARCA membership application/renewal form and fee(s) by ARCA and the depositing of accompanying fee(s) by ARCA do not constitute the issuance of or approval by ARCA of such an application for ARCA membership.

2-2 Acceptance of Membership

A. ARCA may, but is not required to, accept as an ARCA Member any individual or business entity interested in stock car racing, so long as the individual or entity has met the following requirements:

1. Properly and truthfully completed and filed an ARCA membership application;
2. Agreed to abide by the ARCA Rules;
3. Paid the fee(s) prescribed for membership;
4. Meets the required qualifications.

2-2.1 Rejection of Membership

A. ARCA is dedicated to the highest degree of professionalism, sportsmanship and integrity in stock car racing. For that reason, ARCA may reject the membership application of an otherwise qualified applicant in the interest of stock car racing or ARCA, in ARCA's sole discretion.

B. Among other things, participation or involvement by a person or business entity (including, in the case of a business entity, involvement by any stockholder, director, officer, employee, partner or agent thereof) in conduct detrimental to stock car racing or to ARCA, whether in the course of Competition or not, and whether the person or business entity was a Member or applicant at the time of such conduct, may result in rejection of a membership application by ARCA.

C. Any person or business entity whose membership application has been rejected by ARCA may appeal the rejection to the Department of Appeals in accordance with Section 14 Appeals.

2-3 Membership Status

A. An ARCA Member, including a Member who has been issued an ARCA license pursuant to Section 3 Licenses, is not an agent, or employee of ARCA by virtue of such membership or license.

B. With respect to any ARCA-related activities in which a Member engages, unless the Member is also an employee of ARCA, the Member shall act as and be deemed to be either an independent contractor or an employee of a person or entity other than ARCA, and not an agent, or employee of ARCA.

C. Each such Member, or the Member's employer:

1. Is obligated to furnish any tools, supplies or materials necessary to perform the Member's duties.
2. Is responsible for compensating their employees or agents.
3. Assumes all responsibility for any changes, record keeping, premiums and taxes, if any payable on any funds the Member may receive as a result of any activities as an ARCA Member, including but not limited to, social security taxes, unemployment insurance taxes, worker's compensation insurance, income taxes and withholding taxes.

D. A Single Event License may be secured for entry to pit area at ARCA's discretion.

2-4 Suspension

A. ARCA may suspend an ARCA membership at any time in the interest of stock car racing or ARCA, in ARCA's sole discretion.

B. All suspensions are with immediate effect.

C. A suspension may be total, or it may be limited to a suspension of membership and/or license privileges for one or for any combination of the following:

1. At a particular race track or race tracks;
2. For a particular series of Events;
3. For a specified or indefinite period of time, and/or
4. As otherwise determined by ARCA.

D. If the suspension is announced by Penalty Notice stating that the Member is "suspended from ARCA" for a specified or indefinite period of time, then the suspension shall apply to all ARCA-sanctioned Events for such period of time.

E. A Member who is suspended is not eligible to participate, in person, in any ARCA-sanctioned activity, nor to enter restricted areas of an Event (e.g. garage, pits, spotter stand, victory lane, etc.) in which competition or related activities take place.

F. Any special conditions for a suspension will be stated on the Penalty Notice.

G. If the affected Member holds a current and valid ARCA annual photo ID credential, that credential shall not be valid during the period of suspension and may be temporarily revoked by ARCA.

H. Other ARCA privileges will be suspended during the period of suspension.

I. During the period of suspension, the suspended Member is still bound by and subject to the ARCA Rules and all obligations of an ARCA licensed Member.

J. The affected Member shall have no right to receive, and ARCA shall not be obligated to refund, any part or all of the fee(s) previously paid by the Member to ARCA.

K. The affected Member may appeal such a suspension to the Department of Appeals in accordance with Section 14 Appeals.

2-5 Expiration

An ARCA membership expires automatically on the last day of the calendar year in which the membership is issued.

2-6 Ejection

A. An ARCA Supervisory Official may eject a Member from an Event or from the racing premises in an emergency situation as determined by such ARCA Supervisory Official, to promote the orderly conduct of the Event, and/or future Events.

B. An ejection is final, non-appealable and non-reviewable.

2-7 Membership Required

Every person or business entity who desires to participate in an ARCA-sanctioned Event as a Competitor, Official, Promoter, Manufacturer, Sponsor, Sales Representative, or other approved position, must apply for, receive, and possess a valid, current ARCA membership including SEL (Single Event License).

2-8 Medical

For safety reasons, at any time during the calendar year ARCA may require a Competitor to undergo a physical or psychological examination by designated medical professionals at the Competitor's expense.

2-9 Required Notice

Any ARCA Member charged with any violation of the law (misdemeanor and/or felony), shall notify ARCA at compliance@arcacaracing.com prior to the next scheduled Event or within 72 hours of being so charged, whichever is earlier.

SECTION 3 - LICENSES

3-1 Licenses Non-Transferable

A. Licensed Members must present proof of their ARCA license to any ARCA Official(s), at any time, upon request.

B. An ARCA license is non-transferable and non-assignable.

C. An ARCA license may only be used by the Member to whom it is issued.

D. Any attempt by a Member to transfer, lend, or permit any other person or entity to use his/her ARCA license shall be subject to a penalty by ARCA.

E. IF FOR ANY REASON, WHETHER INTENTIONAL OR UNINTENTIONAL, AN ARCA LICENSE IS TRANSFERRED, LOANED, OR USED BY ANY OTHER PERSON OR ENTITY, THE ORIGINAL LICENSED MEMBER SHALL INDEMNIFY ARCA, THEIR PARENT, SUBSIDIARIES AND AFFILIATES, AND ALL RELATED PARTIES FOR ANY DAMAGES ARISING IN CONNECTION WITH SUCH TRANSFER, LOAN, OR USE.

3-2 Minors

A. If the applicant for an ARCA license is a minor under the laws of his/her state/province of residence, the applicant must also submit, with his/her license application, a fully executed and signed Minor's Release and Parental Consent Agreement.

B. The Minor's Release must be signed by the applicant, as well as the applicant's natural father or mother, or by a legal guardian.

C. ARCA may, but is not required to, approve the license application of any applicant who is a minor and otherwise qualified in accordance with this Section.

3-3 ARCA Membership and License Application Types

3-3.1 Competition – Driver License

In order to compete in an ARCA Menards Series and/or ARCA Menards Series East/West Event, a driver must have a current and valid ARCA Driver Membership and License.

3-3.2 Minimum Driver License Requirements

To be eligible for an ARCA Driver License, an ARCA Member must:

A. Be at least 18 years of age except as provided in sub-section 3-3.2.1 (Minimum Driver License Age Eligibility Requirements) below.

B. Submit a Driver Information and Record application to the ARCA Resume Committee outlining his/her previous racing experience. The ARCA Resume Committee will determine if the driver is approved to compete in the ARCA Menards Series and/or ARCA Menards Series East/West and, if approved, which types and sizes of race tracks the driver may compete. Any previously approved driver who has not competed for at least one year, may be required to resubmit the Driver Information and Record application.

C. If requested by ARCA Officials, any driver, including without limitation any starting or relief driver, take and pass driving ability tests prior to an Event, any practice runs, Qualifying or the Race as conducted by and at the discretion of ARCA Officials, whose decision as to the Members driving ability is final and binding on the Member. ARCA may specify, limit, or restrict the types of racing Series or race tracks in which a driver may participate based on the results of the driving ability test(s).

D. Be physically and physiologically fit as determined in the sole discretion of ARCA. In this regard, all drivers must have a completed, current and approved physical on file with ARCA.

E. Any ARCA licensed driver who has been treated by a medical professional is required to confidentially notify ARCA at compliance@arcaracing.com prior to the next scheduled Event or within 72 hours of being treated, whichever is earlier. Failure to notify ARCA may result in disciplinary action.

F. Execute and deliver to ARCA such authorizations, releases, applications, consents, waivers, resumes and other documents as may be required by ARCA from time to time.

G. Have a negative pre-license substance abuse test result on file with ARCA, per the requirements of Section 18 (Substance Abuse Policy).

3-3.2.1 Minimum Driver License Age Eligibility Requirements

A. Minimum 15 years of age

Only eligible (if approved) to compete on tracks 1 mile or less in length, designated road courses and designated ARCA sanctioned Pre-Race Practice sessions and must meet the following requirements:

1. In-person meeting with ARCA Officials;

2. Private on-track test session with ARCA designated observer;

3. To be eligible (if approved) to compete on all tracks over 1 mile up to tracks 1-1/4 mile in length, participant must successfully participate in a minimum of five (5) ARCA Menards Series sanctioned Events or recognized sanctioning body national tour Events on tracks 1 mile or less in length, as defined at ARCA's sole discretion and

4. Successfully participate in ARCA sanctioned Pre-Race Practice (if held) at

track.

5. Any and all requirements to be completed to ARCA's discretion at driver's expense.

B. Minimum 16 years of age

Only eligible (if approved) to compete on tracks 1 mile or less in length, designated road courses and designated ARCA sanctioned Pre-Race Practice sessions.

1. To be eligible (if approved) to compete on all tracks over 1 mile up to tracks 1-1/4 mile in length, participant must successfully participate in a minimum of five (5) ARCA Menards Series sanctioned Events or recognized sanctioning body national tour Events on tracks 1 mile or less in length, as defined at ARCA's sole discretion and
2. Successfully participate in ARCA sanctioned Pre-Race Practice (if held) at track.

C. Minimum 17 years of age

Eligible (if approved) to compete at Designated Intermediate Tracks and must meet the following requirements:

1. Successfully participate in a minimum of five (5) ARCA Menards Series sanctioned Events or recognized sanctioning body national tour Events, as defined at ARCA's sole discretion and
2. Successfully participate in ARCA sanctioned Pre-Race Practice (if held) at track.

D. Minimum 18 years of age

Eligible (if approved) to compete at all oval tracks over one (1) mile in length and must meet the following requirement:

1. Successfully participate in ARCA sanctioned Pre-Race Practice (if held) at track.

3-4 Competition – Car Owner License

A. In order to compete in an ARCA Menards Series and/or ARCA Menards Series East/West Event a Car Owner must have a current and valid ARCA Competition Car Owner Membership and License for the Series in which the Car Owner plans to compete.

B. ARCA will issue the license in the name of the Car Owner as named on the license application.

3-4.1 Minimum Car Owner License Requirements

To be eligible for an ARCA Competition Car Owner Membership and License, an ARCA Member at a minimum must:

- A. Be at least 18 years of age, unless the applicant is a business entity.
- B. Own a race vehicle.

3-4.2 Assigned Vehicle Number

A. All vehicle numbers are owned by and will be assigned by ARCA.

B. ARCA will indicate on the ARCA Competition Owner License the vehicle number assigned to the licensed Member by ARCA.

C. Numbers on a vehicle must correspond with the ARCA Competition Owner License that is on file at ARCA headquarters, unless otherwise authorized by ARCA.

D. The licensed Member may use the vehicle number assigned on the vehicle or vehicles owned by that licensed Member as follows:

1. To identify a particular vehicle during an Event.
2. A number may not be transferred by the licensed Member to another vehicle during the Event unless otherwise authorized by ARCA.
3. To identify a different vehicle owned by the licensed Member at a subsequent event, so long as the vehicle number is not transferred again during the Event unless otherwise authorized by ARCA.

E. Duplicate vehicle numbers will not be permitted. When two (2) or more Car Owners are entered in an Event with the same vehicle number the use of the number will be determined by the highest finishing position from the previous season's final Car Owner point standings for the first three (3) races of the season. After the third race of the season, the use of the number will be determined by the highest position from current Car Owner point standings. In case of a tie, the tie will be broken using the tie breaker as described in Section 17-6.1 until the tie is broken. For non-conjunction events when there are duplicate numbers, the Car Owner that enters an event in the ARCA Menards Series platform that is not their primary series, will be required to change their vehicle number for that event.

F. ARCA reserves the right to revoke, reassign or transfer vehicle numbers to another licensed Member at any time. Vehicle numbers are non-transferable and non-assignable, except by ARCA.

G. If ARCA changes a vehicle number assigned to a licensed Member during the race season, ARCA, at its option, may transfer to the new number the Championship points accumulated by the Car Owner under the previously assigned vehicle number.

H. Championship points and other prizes for Car Owners will be awarded to the licensed Member, depending upon the performance of the vehicle identified by the number assigned to the licensed Member.

3-4.3 Change in Ownership

A. When ARCA is informed of such a change by the licensed Member, or otherwise, ARCA, in its sole discretion, may approve or revoke the ARCA license as of the date of the change or otherwise.

B. ARCA may assign the old vehicle number(s) to the new ARCA Licensed Member, or it may assign a new vehicle number(s).

C. ARCA, in its sole discretion, may assign to the new licensed Member Championship points earned by the former licensed Member, if doing so is in the interest of competition and stock car racing.

D. ARCA may make such other determinations regarding scoring, earning credit for the first place finish, as described in Section 17 (Points and Point Funds), point funds and the distribution of the purse or prize monies as it determines to be in the interest of competition and stock car racing.

3-5 Competition – Crew Member License

In order to compete in an ARCA Menards Series and/or ARCA Menards Series East/West Event, a crew member must have a current and valid ARCA Crew Member Membership and License.

3-5.1 Minimum Crew Member License Requirements

To be eligible for an ARCA Crew License, an ARCA Member at a minimum must:

1. Be at least 15 years of age.
2. Be physically fit to be a crew member, as determined in the sole discretion of ARCA. In this regard, ARCA may require the Member to submit to and pass one or more physical examinations by a qualified physician(s).
3. Execute and deliver to ARCA such authorizations, releases, applications, consents, waivers and other documents as may be required by ARCA from time to time.
4. Be in compliance with ARCA's Substance Abuse Policy (See Section 18).

3-6 Single Event License

A Single Event License may be secured for entry to pit area at ARCA's discretion. Recipient of a Single Event License is ineligible to perform "Over the Wall" activities.

SECTION 4 - INJURY REPORTS

4-1

A. Any Member involved in an accident or otherwise injured while on the racing premises at an Event (e.g. racing surface, pit area, garage area, etc.), must report such incident to an ARCA Official or Medical liaison as soon as practicable, prior to leaving the premises, unless such Member is physically unable to make such a report.

B. Each Competitor agrees and consents that in the event of injury or death in the course of or as a result of an Event, to sign in advance of the Event the necessary waivers to release and provide to ARCA access to copies of any and all medical records of the Competitor related to such an injury or death.

SECTION 5 - SAFETY

5-1 Stock car racing is an inherently dangerous sport. Each ARCA Member assumes the risk of bodily injury, death, or property damage when he/she participates in an Event. The risk of serious injury or death cannot be eliminated and, in fact, will always be present at a high level. Members are required to advise their spouses and next of kin, if any, of this fact.

5-2

A. Member Responsibilities:

Although safety is first priority and a concern for all parties involved in ARCA-sanctioned Events, ARCA cannot be--and is not responsible for--all or even most aspects of the safety efforts required throughout each Event. Such safety responsibilities are instead a shared collaboration across the various Members participating in each Event(s) as outlined in this Section.

B. Promoter:

The Promoter is directly and finally responsible to ensure the following:

1. The racing facilities are adequate for the Event;
2. Adequate safety personnel and equipment are provided for each Event, both for the purpose of preventing injury where reasonably possible and responding to injury when it occurs;
3. The conditions at the racing facility are maintained in a reasonable manner to reduce the risk of injury, all as more fully set forth in the Sanction Agreement applicable to the Event.

C. ARCA:

Employees and representatives of ARCA, when present at an Event, are

responsible for promptly reporting to the Promoter of any inadequacies in the racing facilities, safety personnel and equipment, or other conditions at the racing facilities that are observed and considered to be in their best judgment, inconsistent with the interests of safety.

ARCA works with Competitors, Promoters, vehicle manufacturers and outside independent experts to facilitate, where and when appropriate, the exchange of useful information regarding safety designs, products, practices, and procedures.

Where and when appropriate, ARCA will institute rules or procedures relating to safety.

ARCA Officials are responsible for promptly reporting to the Promoter any inadequacies in the racing facilities, safety personnel and equipment, or other conditions at the racing facility that are observed and considered to be, in their best judgment, inconsistent with the interests of safety.

If an ARCA Official observes any safety inadequacy in a Competitor's race vehicle, racing equipment, or conduct, the ARCA Official may take whatever action is deemed reasonable and appropriate in order to correct such inadequacy. Such action may include, but is not limited to, requests to take physical examinations, substance abuse tests, and/or other driver ability or experience tests.

ARCA IS NOT RESPONSIBLE FOR THE ADEQUACY OF A COMPETITOR'S RACE VEHICLE, RACING EQUIPMENT, OR RACING ACTIVITY TO ACCOMPLISH THIS PURPOSE.

ARCA is not and does not hold itself out as an expert in safety standards, designs, products, practices or procedures, nor is ARCA a standards organization or a designer, manufacturer or seller of safety-related products, facility designs or race vehicle designs.

ARCA DOES NOT MAKE ANY REPRESENTATIONS OR WARRANTIES OF SAFETY TO ANY ARCA MEMBER, RACING FACILITY OR OTHER PERSON OR ENTITY AND CANNOT AND DO NOT TAKE RESPONSIBILITY TO ENSURE THE ADEQUACY - FOR PURPOSES OF SAFETY - OF THE RACING FACILITY, SAFETY PERSONNEL AND EQUIPMENT, AND/OR CONDITIONS AT THE RACING FACILITY. The Promoter and the Competitors are solely and ultimately responsible for such matters at ARCA-sanctioned Events.

D. Competitors:

All Competitors are obligated to inspect for any unsafe condition of the racing facilities, his/her race vehicle and all related equipment, safety personnel and equipment, and/or conditions at the track on a continuing basis before, during and after the Event.

Competitors are responsible for promptly reporting to the Promoter and ARCA Officials any inadequacies in the racing facilities, safety personnel and equipment, or other conditions at the racing facilities that are observed and considered to be, in their best judgment, inconsistent with the interests of safety.

Competitors are solely and directly responsible for the safety of their race vehicles and racing equipment and are obligated to perform their duties in a manner designed to minimize to the degree possible the risk of injury to themselves and others.

NEITHER ARCA NOR THE PROMOTER CAN OR WILL BE RESPONSIBLE FOR THE ADEQUACY OF A COMPETITOR'S RACE VEHICLE, RACING EQUIPMENT, OR RACING ACTIVITY TO ACCOMPLISH THIS PURPOSE.

SECTION 6 - ENTRIES

6-1 Entry Requirements

A. In order to compete in an ARCA-sanctioned Event, all drivers and Car Owners must submit, and have approved, an Official Entry Blank Coupon for the Event.

B. The sole Official Entry Blank is issued by ARCA. For purposes of this Section, "Official Entry Blank" refers to the form of entry required by ARCA for Members to officially enter an ARCA-sanctioned Event.

C. It is the responsibility of the ARCA Member to obtain the appropriate Official Entry Blank, and to ascertain and abide by all applicable deadlines and instructions. The distribution of Official Entry Blanks to Competitors does not relieve them of this responsibility.

D. The Member must complete the Official Entry Blank for the Event in full and submit it to the appropriate office specified on the Official Entry Blank by the deadline listed thereon. The date of submission of the Official Entry Blank will be determined by the date contained in the postal mark, (if mailed), ARCA-recognized courier receipt, the ARCA date stamp, if delivered in person to ARCA, or the submittal date, if sent electronically. Telephone entries will not be accepted.

E. Per the Official Event Entry document, mandated areas on driver uniform and race vehicle are reserved for display of designated sponsor logos. Failure to comply will result in restriction from participating in on-track activity and/or additional penalty.

F. In the event an Official Entry Blank is not submitted by the listed deadline, ARCA, in its sole discretion, may decide to accept the Competitor's entry in which case he/she may be eligible for prize money, provisional starting position(s), ARCA

Championship points or bonus money, if any.

G. Acceptance of any entry is at the discretion of ARCA.

6-2 Advertising and Promotion Release

Each Member, by entering an ARCA-sanctioned Event, grants to ARCA, its duly authorized agents and assigns, a license to use and sub-license his/her name, likeness and performance, including photographs, images and sounds of such Member and/or any vehicle(s) with respect to which the Member competes in ARCA-sanctioned Events, in any way, medium or material (including, but not limited to, telecasts by and through television, cable television, radio, pay-per-view, closed circuit television, satellite signal, digital signal, film productions, audiotape productions, transmissions over the Internet, public and private online services authorized by ARCA, sales and other commercial projects, and the like) for promoting, advertising and publicizing at any time any ARCA-sanctioned Event or ARCA related telecast or programming, before, during and after such Event, and each Member hereby relinquishes to ARCA in perpetuity all rights thereto for such purposes.

6-3 Telecast and Other Rights

A. Each Member, by entering an ARCA-sanctioned Event, acknowledges that ARCA, and its licensees and assigns exclusively and in perpetuity owns any and all rights to broadcast, transmit, film, tape, capture, overhear, photograph, collect or record by any means, process, medium or device (including, but not limited to, television, cable television, radio, pay-per-view, closed circuit television, satellite signal, digital signal, film productions, audiotape productions, transmissions over the Internet, public and private online services authorized by ARCA, sales and other commercial projects, and the like), whether or not currently in existence, all images, sounds and data (including, but not limited to, in-vehicle audio, in-vehicle video, in-vehicle radio, other electronic transmissions between vehicles and crews, and timing and scoring information) arising from or during any ARCA Event or the Member's performance in the Event, and that, ARCA is and shall be the sole owner of any and all copyrights, intellectual property rights, and proprietary rights worldwide in and to these works and in and to any other works, copyrightable or otherwise, created from the images, sounds and data arising from or during any ARCA Event or the Member's performance in the Event.

B. Each Member agrees to take all steps reasonably necessary, and all steps requested by ARCA, to protect, perfect or effectuate ARCA's ownership or other interest in these rights.

C. Each Member agrees not to take any action, nor cause others to take any action, nor enter into any third-party agreement that would contravene, diminish, encroach or infringe upon these ARCA rights.

SECTION 7 – APPROVED PIT SUPPORT VEHICLE USAGE

7-1 Approved Pit Support Vehicle Usage in Garage

A. Pit support vehicle application can be obtained from arcaracing.com website or the ARCA office.

B. Approved pit support vehicle will only be allowed at designated race tracks as specified on the Pit Support vehicle application.

C. Only one (1) approved pit support vehicle per team.

D. Approved pit support vehicle can only be used during designated or authorized hours (typically, load-in, load-out and pit setup only).

E. Approved pit support vehicle must have the associated team vehicle number visible.

F. A maximum of two (2) operators per event and both must hold a valid ARCA license.

G. Operators must hold a valid government-issued driver license.

H. A permit must be acquired from ARCA prior to pit support vehicle use.

I. Team must have approved certificate of liability insurance on file with ARCA.

J. Driver must operate pit support vehicle in a safe manner (speed/riders/load) at ARCA's sole discretion.

K. Operating pit support vehicle in an unapproved area, unapproved time and/or manner will result in loss of privileges and/or penalties including monetary fine and restriction from participating in on-track activities.

7-2 Unmanned Aircraft Systems (UAS)

The use of Unmanned Aircraft Systems (UAS) or drones is strictly prohibited at any time.

SECTION 8 - INSPECTIONS AND ELIGIBILITY

Prior to use in any Event all Race Equipment described in Sections 20C must be submitted to ARCA Officials for consideration of approval and approved by ARCA.

The Race Equipment above may thereafter be used in its approved form until ARCA determines that the equipment is no longer eligible for competition.

8-1 Time / Manner / Location

A. All Race Equipment, including but not limited to vehicles, vehicle parts, components, equipment and/or fuel, is subject to inspection by ARCA, at any time and in any manner and location as determined by ARCA Officials in its sole discretion.

B. All decisions by ARCA regarding the timing, manner and location of inspection, as well as what Race Equipment will be inspected, are final, non-appealable and non-reviewable except as provided in sub-section 1-5 Finality of Interpretation and Application.

8-2 Inspection Area

Only those persons approved by ARCA Officials may be admitted to the inspection area(s).

8-3 Vehicle Eligibility

A. ARCA will determine whether a vehicle including any Race Equipment meets the applicable specifications for an Event as set forth in the ARCA Rules, as it may be amended from time to time, and any special rules published by ARCA for an Event.

B. Only Race Equipment determined by ARCA to meet the applicable specifications is eligible to compete in the Event.

C. Such determinations may be made by ARCA Officials at any time before, during, or after the Event, and may consider, to the extent deemed reasonable by ARCA in the interests of racing competition and fairness, any modifications caused or required as a result of damage caused by in-race accidents.

8-3.1 Backup Vehicle

A. Throughout the Event, the Car Owner must compete with the original vehicle that is presented for initial inspection, unless the vehicle has been damaged beyond a timely repair.

B. The Series Director will make the determination of whether a vehicle is damaged beyond a timely repair.

C. A backup vehicle may not be unloaded at any time, unless approved by the Series Director.

D. Under no circumstances will the Car Owner be permitted to use a backup vehicle if, in the judgment of the Series Director, the original vehicle was intentionally damaged.

E. After a vehicle has completed initial inspection, at the discretion of the Series Director, a vehicle that has sustained severe damage as a result of an on-track incident may be removed from the track premises for adequate repairs.

F. Any backup vehicle must pass the ARCA inspection.

8-4 Competitor Obligation

A. A Competitor must take whatever steps that are requested by ARCA Officials, including disassembly of the vehicle, to facilitate inspection of the Race Equipment.

B. This obligation includes, but is not limited to, installing inspection holes, inspection ports, and/or other means of inspection in the frame components, roll cage bars, engine components, and the like.

C. ARCA is not responsible for payment, reimbursement, damage or loss to the Competitor as a result of such inspections.

8-5 Inspection

8-5.1 Inspection Prior to Competition

A. If ARCA determines prior to the competition that a vehicle, including Race Equipment, does not meet the applicable specifications, the vehicle will not be allowed to compete. The Series Director may make an exception to this if the deficiency:

1. Will not adversely affect the orderly conduct of the Race;
2. Cannot be corrected in time for Qualifying or for the Race (if no Qualifying or if the deficiency is discovered after Qualifying but prior to the Race);
3. Is so insubstantial as not to warrant a determination that the vehicle is ineligible to compete in the Race.

B. If the Series Director permits the vehicle to compete under these circumstances, the Competitor will be notified in writing of the deficiency and specify the date and time in which the deficiency must be corrected.

C. If the deficiency has not been corrected by the date and time specified, a penalty may be imposed by the Series Director.

D. The vehicle will be prohibited from competing in any future Event(s) until the deficiency has been corrected.

E. Unless otherwise authorized by the Series Director, once a vehicle has been presented at the beginning of the inspection procedure for either Qualifying or the

Race, the vehicle must not be removed from the inspection procedure until after Qualifying or the Race has been completed.

8-5.2 Inspection After Competition

A. At an Event where the ARCA Rules, special rules, or ARCA requires inspection after the Event, Race Equipment that has competed in the Event may not be taken from the racing premises without permission from the Series Director.

B. If ARCA determines after the Race that any Race Equipment, including the vehicle, does not meet the ARCA Rules or any special rules published by ARCA for the Event, the Series Director may make an exception to this if the deficiency is so insubstantial as not to warrant a determination that the Race Equipment was ineligible for the Event. Under this circumstance, the Series Director will apprise the Competitor in writing of the deficiency and direct the Competitor to correct the deficiency for future Events.

C. The vehicle will be prohibited from competing in any future Event until the deficiency has been corrected.

8-5.2.1 Inspection After Competition Procedure

A. Upon finishing their cool-down lap after the completion of the Race, all vehicles must report to pit road or designated area but must not leave pit road or the designated area until directed to do so by ARCA.

B. All vehicles are considered under impound from the moment they receive the checkered flag, or the Race is declared complete due to adverse conditions. Vehicles must not be altered or adjusted in any manner during the cool-down lap or on pit road prior to reporting to the inspection area(s).

C. The first-place vehicle may engage in appropriate celebratory activity (such as a victory lap, burn-out(s) or donuts') prior to reporting to Victory Lane.

D. Vehicles that finish in second through fifth place and any other vehicles randomly selected or otherwise determined by ARCA to require additional inspection for any reason must report to the inspection area(s).

E. ARCA, at its sole discretion, may analyze the performance capabilities of a vehicle, vehicle part, component or equipment at the race track or any other location including but not limited to, remote or third-party testing facilities.

F. ARCA, at its sole discretion, may confiscate any vehicle, vehicle part, component, equipment, fuel and/or tires that fail to meet ARCA specifications or that appears to be altered in violation of the ARCA Rules for further evaluation.

G. The maximum amount of cooling time permitted for any engine after the official completion of the Race is two (2) hours.

H. ARCA Officials may assess a fine and/or loss of championship points, and/or loss of finishing positions in the Event for any engine that requires additional cooling time in excess of the maximum cooling down time of two (2) hours. See sub-sections 12-4 General Scope of Penalties & 12-5 ARCA Deterrence System.

8-6 Vehicle Sealing / Impounding

8-6.1 Sealing / Impounding Initiated by ARCA

A. ARCA may, for inspection purposes, seal or impound any Race Equipment entered and competing in an Event.

B. ARCA may seal or impound any Race Equipment to conduct an analysis of the performance capabilities of the Race Equipment. See sub-section 8-8 Competitive Analysis.

C. ARCA is not responsible for payment, reimbursement, damage or loss to the Competitor as a result of such sealing or impounding.

8-6.2 Impound Events

A. In Events where vehicles are impounded after inspection or Qualifying, only repairs or adjustments authorized by ARCA may be performed.

B. Unauthorized repairs and/or adjustments may result in a penalty.

8-7 Vehicles / Equipment / Parts Failing to Meet Specifications

A. ARCA may confiscate any Race Equipment, without obligation for payment or reimbursement, which fails to meet applicable ARCA specifications during an Event or that is used or altered in violation of the ARCA Rules, in ARCA's sole discretion.

B. If ARCA determines that any Race Equipment used by a Competitor does not meet ARCA specifications or is used or altered in violation of the ARCA Rules, ARCA may:

1. Declare the vehicle and/or Race Equipment ineligible for the Event;
2. Disallow the Competitor's Qualifying times;
3. Disallow the Competitor's Practice times;
4. Withdraw the Competitor's opportunity to qualify for the Event;
5. Loss of finishing position;
6. Disqualification of the Competitor(s) from the Event, and/or
7. Make such other determinations as may be appropriate in the interest of competition.

C. The above actions are in addition to all remedies available to ARCA under

Section 12 Violations and Disciplinary Action, will not be deemed or construed to be a penalty within the meaning of Section 12 Violations and Disciplinary Action and is not appealable under that Section.

8-8 Competitive Analysis

A. ARCA may determine, in the interest of competition that it is necessary or appropriate to conduct an analysis of the performance capabilities of Race Equipment.

B. The Competitor shall take whatever steps are requested by ARCA for this purpose.

C. ARCA may seal or impound Race Equipment for this purpose.

D. ARCA is not responsible for payment, reimbursement, damage or loss to the Competitor as a result of such analysis, sealing or impounding.

E. If, in the judgment of ARCA, any Race Equipment that has been altered or modified or any action(s) or procedure(s) were conducted to compromise the results of the competitive analysis, ARCA may assess penalties pursuant to Section 12 Violations and Disciplinary Action.

F. If, in the judgment of ARCA, any action(s) or procedure(s) were conducted with the intent to alter or compromise the results of the competitive analysis, ARCA may assess penalties pursuant to Section 12 Violations and Disciplinary Action.

8-9 Finality of Inspection / Eligibility Decisions

Inspection and/or eligibility decisions, including any decision regarding a Competitor's compliance with equipment-related procedures set forth in the ARCA Rules, are final, non-appealable and non-reviewable except as provided in subsection 1-5 Finality of Interpretation and Application.

8-10 Penalties

In addition to making the inspection and/or eligibility decisions described in this Section, ARCA may issue a Penalty Notice for any violation of the ARCA Rules in accordance with the procedures in Section 12 Violations and Disciplinary Action.

8-11 Certification

A. ARCA, in its sole discretion, may require a Competitor to submit Race Equipment to ARCA before being permitted for use in an Event, for the purposes of permitting ARCA to certify that it is in compliance with the ARCA Rules.

B. Once Race Equipment has been certified by ARCA as being in compliance with the ARCA Rules, it must not be altered, modified, repaired or changed in any manner without prior written notification to and approval by ARCA. If ARCA determines, in its sole discretion, that previously certified Race Equipment may have been altered, modified, repaired or changed in any manner, ARCA may require the Race Equipment be submitted to ARCA for re-certification before further use in an Event.

C. After the Race Equipment has been certified and/or encrypted, ARCA certification verification(s) may be installed on the Race Equipment. It is the responsibility of the team(s) to maintain the original integrity of the encryption and ARCA certification verification(s).

SECTION 9 - EVENT PROCEDURE

9-1 Event Procedure Defined

A. Event Procedure is the manner in which an Event and all associated activities are conducted. Event Procedure includes, but is not limited to:

1. Inspection determinations regarding the eligibility of vehicles for competition;
2. Determinations regarding the eligibility of a driver(s) for competition;
3. A Team/Competitor's compliance with competition-related procedures as set forth in the ARCA Rules;
4. Practice procedures;
5. Qualifying procedures;
6. Race starting grid position determination;
7. The line-up of vehicles;
8. The start of the Qualifying or Race;
9. The control of vehicles throughout the Event by flags, lights or other direct communication between ARCA and Team/Competitors;
10. The election to stop or delay an Event;
11. Control of pit activity;
12. The use of flags;
13. Positioning of vehicles during the Event;
14. Addition or subtraction of lap(s);
15. Assessment of lap and time penalties;
16. Completion of Qualifying session or Race.

B. Event Procedure does not include the assessment of penalties pursuant to Section 12 Violations and Disciplinary Action (disqualification, suspension, point deduction or fine), but it does include assessment of lap and/or time penalties and similar actions taken by ARCA during a Race or immediately after a Race as provided in this Section.

C. The rules in this Section provide the framework for ARCA to implement Event Procedures.

D. In addition to interpreting and applying these rules, ARCA Officials are authorized to make such other determinations or take such other action as they determine to be necessary to promote the best interests of ARCA racing, including but not limited to fairness and prompt finality of competition results.

9-2 Finality of Event Procedure Decisions

A. All decisions by ARCA Officials at the track involving Event procedures are final and non-appealable, subject only to review by ARCA Supervisory Official(s) if one or more such Officials determine that extraordinary circumstances exist that require such review. In making such a determination, the interest of finality in competition results will be a principal consideration.

B. ARCA Supervisory Officials will not review any Event Procedure decision unless it has been brought to their attention by an affected Competitor within 20 minutes after the posting by ARCA of the results of the Practice, Qualifying session(s) or Race at which the Event Procedure decision was first made.

C. If an ARCA Supervisory Official determines that the Event Procedure decision should be reviewed, and that the decision was in error, the Supervisory Official(s) may take whatever action deemed appropriate to initiate a remedy to further the interests of fairness and finality in competition results. Such action includes, but is not limited to:

1. Revising Practice results;
2. Revising Qualifying results;
3. Revising the final Race results;
4. Awarding or subtracting finishing position(s);
5. Awarding or subtracting point(s) ;
6. Imposing penalties (disqualifications, suspensions or fines).

D. The Supervisory Official(s) may alternatively elect not to take remedial action. All such decisions are final and non-appealable (except the imposition of a penalty, as provided in Section 12 Violations and Disciplinary Action).

9-3 On-Track Incident Procedure

A. During an Event, if a vehicle sustains damage from an accident or contact of any kind and/or is stopped on or near the racing surface and unable to continue to make forward progress, unless extenuating emergency conditions exist with the race vehicle (e.g. fire, smoke in the cockpit, etc.) the driver should take the following steps:

1. Shut off electrical power and, if driver is uninjured, lower driver's window net.
2. Do not loosen, disconnect or remove any driver personal safety equipment until directed to do so by safety personnel or an ARCA Official.
3. After being directed to exit the vehicle, the driver must immediately proceed to either the ambulance, other vehicle or as otherwise directed by safety personnel or an ARCA Official.
4. At no time should a driver or crew member(s) approach any portion of the racing surface or apron.
5. At no time should a driver or crew member(s) approach another moving vehicle.

B. All vehicles not involved in the incident or that are able to continue afterwards should slow down to a cautious speed as outlined in sub-section 10-2.3 (Yellow Flag / Caution Lights), use extreme care as they approach an incident scene, and follow any directions given by safety personnel or ARCA Officials.

C. Vehicles in line behind safety vehicle should not weave or otherwise stray from the line in the vicinity of the incident.

9-4 Driver Changes

A. Change of the driver at any time must not be made without advance notification to and approval by the Series Director.

B. If a driver change is made before the start of a Race, the vehicle must relinquish its starting position and start at the "Tail of the Field". Driver points will be awarded only to the starting driver.

C. Driver changes will not be permitted from the start of pace lap(s) until after the vehicle completes its first scored lap.

D. If a driver change is made while the red flag is displayed for an on-track incident or scheduled break, the vehicle must relinquish its position and move to the "Tail of the Field" when the Race is resumed and remain there until a green flag restart.

9-4.1 Rookie Driver

The Series Director shall be the sole judge of whether an individual is a rookie,

based on the individual's prior racing experience, including but not limited to, the individual's racing experience at the Event facility and in the Series for which the Event is a part.

1. Drivers may be designated and considered for Rookie of the year Award if:
 - a. Driver has not competed in more than 20 events or four (4) years in the ARCA Menards Series Platform. Competing in an event in this application will be defined as starting and completing more than ten (10) laps in the event,
 - b. Driver has not competed in seven (7) career races in the National Series (NCS, NXS, NCTS),
 - c. the driver turns 18 years of age after the start of the racing season, said driver may be considered for Rookie eligibility the following year, pending compliance with "A" and "B" above.
2. If a driver is a rookie at the beginning of the year, said driver will be considered a rookie for the season.
3. A driver may not win both Rookie of the year award and Driving Championship in the same season.

9-5 Starting Position Procedure

- A. A driver may not attempt to qualify more than one (1) vehicle.
- B. A vehicle may only make one (1) qualifying attempt per Qualifying session unless otherwise authorized by the Series Director.
- C. The fastest single lap time posted to each vehicle will determine its starting position as set forth in this sub-section 9-5.
- D. When two (2) or more vehicles have the same Qualifying times, the starting position for those vehicles in the Event shall be determined by the current calendar year ARCA Championship Car Owner point standings in the Series for which the Event is a part. For purposes of the foregoing sentence, the previous calendar year's final Car Owner point standings shall be used until the completion of the third Championship Event. If point standings do not prevail, then the driver setting the duplicate time first would start in front of the other.
- E. **PROVISIONAL POSITIONS:** For the first three (3) races of the season, provisional positions will be determined from the previous season's final Car Owner point standings. After the third race of the season, provisional positions will be determined from current Car Owner point standings. Any provisional starter (driver and/or vehicle) must prove, to ARCA Officials discretion, ability to maintain minimum race time.
- F. **PAST CHAMPION PROVISIONAL:** One provisional, as designated on the Official Entry Blank for the Event is reserved for a past ARCA Racing Series champion driver who failed to qualify for the Event. To be eligible, the driver must have entered before the deadline and competed in said Event. If more than one (1) driver is eligible, the most recent past champion will receive the starting position using the past champion provisional. Using the same eligibility criteria, if there is no past champion driver eligible, the past champion provisional may be awarded to a past champion Car Owner.
- G. The procedure for the Qualifying session(s) will be established by ARCA Officials and will be part of the Official Entry Blank for the Event. Any changes to the procedures will be announced and/or posted to the drivers and/or crew chiefs before the Qualifying session(s).
- H. When Group Qualifying sessions are part of the procedure to set the starting field for the Event, the Series Director will make the determination of number of groups, number of vehicles in each group and set the time for each group during the Qualifying session.
- I. Group Qualifying session shall be made known to all Drivers, Owners and Crew Chiefs by way of the Event information and Procedures mailed out prior to the Event.

9-5.1 Starting Position Eligibility/Determination – Adverse Conditions

- A. **No practice:** Pole to last starting position as follows:
 1. Car Owner point standings (previous season for 1st 3 races of season, current after that);
 2. Number of events entered and competed in;
 3. Random draw;
 4. The final starting position shall be reserved as referenced above for a past champion.
- B. **Practice/Partial Practice:** When qualifying is cancelled, cars will be lined up based on fastest practice time posted in practice session(s) (see C.) for all non-provisional starting positions. Provisional positions will be based on;
 1. Car Owner point standings (previous season for 1st 3 races of season, current after that);
 2. Number of events entered and competed in;
 3. Random draw;
 4. The final starting position shall be reserved as referenced above for a past champion.

C. ARCA Officials will determine in their sole discretion if all vehicles have had a reasonable opportunity to practice.

D. If cars have not been on track by the scheduled qualifying time, the starting field will be set by Car Owner points (first 3 events, previous years points. Current after that).

E. When Combination Events are held and the Qualifying session(s) are not completed due to weather or other adverse circumstances, the sequence of procedures above will be used and divided equally between the Series competing in the Combination Event. The National Series will be considered primary Series of the event unless otherwise noted on the Entry Blank.

9-6 Race Start

9-6.1 Backup Vehicle

A. Once Qualifying has begun (whether completed or not), or the starting field has been determined, if a back-up vehicle is used, the vehicle must start the Race at the "Tail of the Field".

B. If Qualifying is not completed due to weather or other adverse circumstances, and a back-up vehicle was authorized prior to the starting field being determined, the Series Director will make the determination whether a backup vehicle has had adequate practice to remain eligible for its assigned starting position.

C. If the determination is made that the vehicle is not eligible for its assigned starting position, the vehicle will start at the "Tail of the Field".

9-6.2 Starting Position

A. All vehicles that are in the official starting line-up must be on the starting grid ready to participate five (5) minutes before the pace laps start unless otherwise directed by the Series Director.

B. Any vehicle in the starting line-up and on the starting grid will be permitted to enter the Race at any time after the pace laps start.

C. At Events where the vehicles are impounded by ARCA after the starting line-up is determined, teams will not be permitted to make any repairs, adjustments, add fuel, changes of vehicle parts and/or components before the affected vehicle receives the green flag on the race track, unless otherwise authorized by the Series Director.

D. If the Series Director begins a Race under green/yellow flag conditions, teams will not be permitted to make any repairs, adjustments, add fuel, changes of vehicle parts and/or components until the yellow flag is withdrawn. Failure to comply with this rule may result in a penalty at the discretion of the Series Director.

E. Unless otherwise directed by ARCA, the vehicle awarded the pole position will be given the choice of starting on the inside (pole) or taking the outside position in the front row. The choice must be made by the time the field receives the one lap to go to green signal. The vehicle awarded the pole position is the control car and will bring the field to the green.

F. During the pace laps, if a vehicle does not maintain its designated position in the starting field, ARCA may reposition the car at their discretion.

G. If a vehicle retires during the pace laps or before completing the first official lap, and thereafter fails to return to the Race, its finishing position will be determined by its starting position in relation to other vehicles that do not complete the first official lap (EIRI).

H. If a vehicle does not leave the Race starting grid and thereafter fails to return to the Race, the vehicle's finishing position will be behind those vehicles that depart the Race starting grid and will be determined by its starting position in relation to the other vehicles that do not leave the Race starting grid (EIRI).

I. At the initial start of the race, the starter will display the green flag at his/her discretion. Once the green flag is displayed, all vehicles must maintain their respective track position/lane as designated by ARCA Officials until they reach the start/finish line. At the initial start of the Race the number two (2) starting position must not beat the number one (1) starting position to the start/finish line.

J. ARCA, at its discretion, may use a predetermined scheduled caution period(s) or break(s) that will be made known to all Competitors.

9-6.3 Addition of Fuel

A. The addition of fuel will not be permitted from the time the engines are started until after the affected vehicle receives the green flag on the race track.

B. If the Series Director begins a Race under green/yellow flag conditions, the addition of fuel will not be permitted until the yellow flag is withdrawn, doing so will result in a minimum of a one (1) lap penalty.

C. At Events, where the addition of fuel will not be permitted except at designated times during the Event, the designated times will be provided on the Crew Chief Handout, the Crew Chief Handout can be obtained at the Driver, Spotter & Crew Chief Meeting.

9-7 Race Halt / Caution Period

A. ARCA will determine whether the race track is suitable for competition.

B. A Race may be stopped at the discretion of the ARCA Officials at any time they determine, or in the exercise of their independent judgment, that the track is not suitable for competition.

C. Upon resuming the Race, following a Race halt and/or during a caution period, all subsequent laps will be scored.

9-8 Restart

When the red flag is displayed and the Race is stopped before or after the completion of at least one (1) scored lap, vehicles will line up in their respective track order in which they were scored. If there is no restart, and the Race is declared official, the vehicles will be scored as described in sub-section 9-14D Official Completion.

9-8.1 Double File Restart Order (Double File)

A. Restart procedures will be made known at the Pre-Race driver, spotter and crew chief meeting.

B. When the starter gives the “one (1) lap to go” signal, unless otherwise directed by ARCA Officials, vehicles will line up in columns of two (2) for all restarts in the following “Double File” format after they reach the start/finish line.

1. The leader will have column/lane selection for each restart and is the control vehicle for the restart.
2. The third place vehicle, in scored order and all vehicles with an odd numbered starting position must line up on the inside column/lane.
3. The fourth place vehicle, in scored order and all vehicles with an even numbered starting position must start on the outside column/lane.

Vehicles will be lined-up in “Double File” in the following order:

- a. Lead lap vehicle(s) that maintained their respective track position and did not enter pit road.
- b. Lead lap vehicle(s) that entered pit road only once, on the designated lap during this caution period when pit road was open, in proper alignment after returning to the race track.
- c. Lap(s) down vehicle(s) that maintained their respective track position and did not enter pit road, during this caution period.
- d. Lap down vehicles(s) that have entered pit road only once, on the designated lap during this caution period when pit road was open, in proper alignment after returning to the track.
- e. The highest scored non-lead lap vehicle (“Free Pass”) at the time of caution.
- f. The “Wave Around” vehicle(s) must maintain their respective track position and receive the Green Flag on the race track before being permitted to enter pit road without a penalty.
- g. Vehicle(s) that have been issued a race procedure penalty including vehicles that pitted more than once will be at the “Tail of the Field” in their respective track position.
- h. Vehicles exiting pit road once the “one to go” signal is given will restart at the tail of the field.

C. All restarts shall be made at a designated point on the race track and will be made known to the drivers in the driver, spotter and crew chief meeting.

D. The leader of the Race will control the restart within the designated location on the race track. Once the green flag is displayed, all vehicles must maintain their respective track position/lane as designated by ARCA Officials until they reach the start/finish line.

E. At ARCA’s discretion, a single file restart option may be used and will be made known at the driver, spotter and crew chief meeting.

9-9 Adverse Circumstances

A. When an Event is halted due to rain, curfew or adverse circumstances, the Event may be rescheduled to a date and time to be determined by ARCA.

B. Unless otherwise determined by ARCA, the rescheduled Event shall start with the incomplete portion of the previous Race and all original entries shall start in the position they held when the Race was stopped.

9-10 Lap or Time Penalties

A. A lap or time penalty is the act during a Race of detaining a vehicle and its driver for a specified amount of time or number of lap(s), whichever is appropriate as determined by ARCA Officials.

B. A lap or time penalty is not a “penalty” within the meaning of Section 12 Violations and Disciplinary Action and is not appealable under that Section.

C. A lap or time penalty may be imposed when the Competitor has violated the ARCA Rules.

Types of Lap or Time Penalties Defined

1. Tail of the Field Penalty – When the “one to go” signal is given by the starter all vehicles that are under a “tail of the field” penalty will move to the inside of the two (2) columns of vehicles and reposition to the tail of the field.
2. Pass-Through Penalty – The vehicle under penalty will enter pit road

and drive the entire length of pit road without stopping. If the vehicle exceeds pit road speed while performing a pass-through penalty, additional penalties may be assessed at ARCA's discretion.

3. One-Lap Penalty - Under green flag conditions, the vehicle under penalty must enter pit road and make a mandatory stop in its designated pit. Crew members may not perform any service (including fueling) or work on the vehicle while it is serving a one-lap penalty. An ARCA Official may stand at the front of the vehicle under penalty. The Official will note the group of vehicles that is passing now on the race track and will release the vehicle from its pit when the group of vehicles returns and are in the ARCA Official's field of vision.

Under Yellow flag conditions, the vehicle must enter pit road and make a mandatory stop in its designated pit. Crew members may not perform any service (including fueling) or work on the vehicle while it is serving a one-lap penalty. An ARCA Official may stand at the front of the vehicle under penalty. Once the caution vehicle and the continuous line of vehicles on the race track pass, the ARCA Official will then release the vehicle from its pit. This vehicle will be required to restart at the "Tail of the Field", on the one to go lap.

4. Additional Violation(s) Incurred – If a vehicle exceeded pit road speed or incurred an additional violation(s) while serving the original penalty, under this circumstance ARCA may, in its discretion, issue subsequent penalties to the vehicle.

In-Race Violations

A lap or time penalty may be imposed when the Competitor has violated a directive from an ARCA Official, or a known pit road or Race procedure including but not limited to the following:

1. Intentionally causing or attempting to cause a caution period;
2. Reckless driving;
3. Passing the caution vehicle;
4. Going above the pre-established blend line when exiting pit road;
5. Passing prior to the start/finish line on the initial start;
6. Restart violation;
7. Verbal abuse of, or inappropriate gestures to ARCA Officials;
8. Safety Violations.

Road Course Events/Additional In-Race Violations

A. In the judgement of ARCA, short cutting the course may result in a "pass-through" penalty. If, in the closing laps of the Race, the "pass-through" penalty has not been served, a 30 second time penalty will be added to the vehicle's total time by scoring. The scoring results will be adjusted before the posting of the Race results.

B. Additional In-Race penalties may be assessed during an Event. The additional In-Race Violations and penalties will be made known to Competitors during the driver, spotter and crew chief meeting.

Post-Race Violations

A Competitor shall not receive a lap or time penalty after the completion of the Race unless in the closing laps of the Race, a Competitor violates:

1. The ARCA Rules;
2. A directive from ARCA, or a known Race or pit road procedure, and there are not enough laps or time remaining in the Race for the ARCA Officials to impose a lap or time penalty.

If a post-Race lap or time penalty is imposed, a scoring correction reflecting the penalty will be permitted prior to the posting of official Race results.

9-11 Parking

An ARCA Supervisory Official may direct a Competitor to cease competition, to leave the racing premises, or to bring the vehicle to the pit road and/or garage area for a specified number of lap(s) and/or a specified time penalty, for the balance of Practice, Qualifying, the Race or future ARCA Races, if it is necessary to do so in order to promote the orderly conduct of the ARCA Event(s). Such a directive will be given only in extraordinary circumstances, as determined by the ARCA Supervisory Official(s). It will not be deemed or construed to be a disqualification, suspension or other "penalty" within the meaning of Section 12 Violations and Disciplinary Action and is not appealable under that Section.

9-12 Race Start / Finish Line

A. The start/finish line extends from the grandstand (outside) retaining wall to the pit service (inside) wall or a designated point in the infield.

B. Unless otherwise authorized by the Chief Scorer, the vertical plane at the leading edge of the start/finish line is the scoring point for the vehicle.

C. A vehicle is accredited a completed lap when the furthestmost forward component of the vehicle intersects the vertical plane at the leading edge of the start/finish line, as determined by the Chief Scorer.

9-13 Official Completion

A. All Races will be run until the leader has completed the required Race distance, which means the advertised distance in the Official Entry Blank, except as described in sub-section 9-13.1 and 9-13.2.

B. In the event two or more vehicles have the same finishing position (tie) and the tie cannot be broken by any practical means reasonably available to ARCA, the tie will be broken as follows:

1. By awarding the higher finishing position to the vehicle that led the greatest number of laps in the Race in which the tie occurred.
2. If a tie still exists after that, the greatest number of laps completed in second place, third place, etc. will be used in the same manner, until the tie is broken.
3. If the tie is not resolved by the above, the vehicle scoring the highest position on any lap during the Race will prevail, or in the case where the highest position scored between the tied vehicles is the same, the vehicle scoring the highest position at the earliest point in the Race will prevail.

9-13.1 Required Race Distance is Greater Than Advertised Distance (ARCA Overtime)

A. When the Race is under caution during the closing laps, the Race distance may be extended beyond the advertised distance into ARCA Overtime. The Overtime procedure for the Event will be made known at the driver, spotter and crew chief meeting.

B. ARCA Overtime will be in effect under the following circumstance:

- If the caution lights are illuminated and/or yellow flag is displayed prior to the leader crossing the start/finish line to receive the scheduled checkered flag in the advertised distance of the Race.

C. A Race that is extended and restarted in ARCA Overtime will consist of one or more restart attempt(s) and requires the leader's vehicle to break the vertical plane of the leading edge of the start/finish line under green flag conditions. A restart attempt will consist of a green flag lap on the restart, followed by a white flag lap and a checkered flag finish.

D. If the caution lights are illuminated and/or the yellow flag is displayed after the leader's vehicle breaks the vertical plane of the leading edge of the start/finish line on the white flag lap, the Overtime attempt will not be official and subsequent attempt(s) will be made consisting of a green and white flag on the restart followed by the checkered flag until an official attempt occurs (i.e. the leader's vehicle breaks the vertical plane of the leading edge of the start/finish line under a green flag condition).

E. Single Attempt Overtime finish

A. If needed, there will only be one (1) attempt at a Green/White-Checker overtime finish.

B. Once the leader has received the white flag under green flag conditions at the start/finish line, the next flag will end the race. If the caution lights are illuminated and/or yellow flag displayed the field is frozen in the vehicles respective track position, provided the vehicles return to the start/finish line to complete their lap without assistance while maintaining a reasonable speed considering the track conditions.

C. Once caution is displayed, vehicle(s) returning to the start/finish line are not permitted to pass, must be unassisted and maintain their position in relation to other vehicles doing the same.

D. In the circumstances of a caution period, a vehicle's reasonable speed and track conditions are an ARCA judgment determination.

E. ARCA will use any available data or resources to determine the respective track position of each vehicle at the time the caution period began on the white flag lap. Such resources include, but not limited to:

- Undisputed video proof of a vehicle's track position at the time of caution in the judgment of ARCA Timing & Scoring.
- Order of the last passed detection scoring data (scoring loop).

F. Those vehicle(s) involved in the accident in the judgment of ARCA Officials will be repositioned by ARCA Timing & Scoring.

- Vehicles that return from their involvement in the accident unassisted, returning to the start/finish line once they re-establish a reasonable speed for the conditions.
- Vehicle(s) that do not complete this lap.
- Vehicles are not permitted to continue to complete the lap, when the red flag is displayed.

9-13.2 Required Race Distance is Less than Advertised Distance

If the halfway distance has been reached or surpassed by the leader, ARCA determines in its sole discretion that unforeseen circumstances prevent the completion of the advertised distance or make it impractical to continue or complete the Race within a reasonable time after it has been stopped, the Race will be

considered officially completed as of the last lap completed by the leader prior to the Race halt. The finishing positions will be determined as they would have held if the Race had been restarted.

9-14 Pit Procedures During the Race

A. Drivers or vehicles may receive pit stop service only when they are in their assigned pit box, and/or the garage area or at ARCA's discretion.

B. All pit stops are to be made according to procedure as determined and made known at the driver, spotter and crew chief meeting.

C. If in the judgment of ARCA Officials an infraction of a pit road procedure is insubstantial or inconclusive as not to warrant a penalty, the ARCA Officials will advise the crew chief of the infraction and may elect not to assess a penalty. As set forth in sub-section 9-10 Lap or Time Penalties, lap or time penalties may be assessed for any violation of the ARCA Rules, including without limitation the foregoing pit procedure rules and as set forth on the pit road procedure card.

D. When following the caution vehicle during a caution period, drivers must maintain their position in relation to other vehicles in the field or as otherwise directed by ARCA Officials and will not be permitted to pass other vehicles or the caution vehicle when preparing to enter pit road.

9-14.1 Pit Road

A. Vehicles must enter the pit road in a single file line.

B. After a vehicle commits to their assigned pit box the vehicle behind may pass to the outside.

C. Vehicles may not be pushed past the ARCA Official at the end of the pit road.

D. Unless otherwise authorized, once the Race is underway, vehicles may be started by hand pushing in the pit area only, but under no circumstances is any vehicle to be hand pushed into the acceleration zone or onto the race track from the pit area.

E. Vehicles returning to the race track from pit road during a caution period must wait for the end of the continuous line of vehicles behind the caution vehicle, unless otherwise directed by ARCA Officials.

9-14.2 Pit Road Speed

A. Vehicles must not exceed the pit road speed limit determined by ARCA for each Event. The pit road speed limit will be made known to all Competitors in the driver, spotter and crew chief meeting.

B. Vehicles entering pit road must be single file and maintain the pit road speed the entire length of pit road.

C. When forced onto pit road while avoiding an accident on the race track, vehicle speed is to be reduced the entire length of pit road.

D. Vehicle(s) are not permitted to speed to prevent the loss of a lap at the start/finish line or at pit road exit.

9-14.3 Pit Box / Pit Service Area

A. It is the responsibility of each driver to position his/her vehicle within the assigned pit box or pit service area.

B. When the pit road has defined pit boxes with lines, each vehicle must be within the designated lines of its assigned pit box to be considered "in the box."

C. Unless otherwise authorized by ARCA, a vehicle is considered "outside the box" if any of the following occur:

1. The outside front tire of the vehicle is on or over the outside line of the pit box;
2. If any part of the vehicle is visibly on top of or over the front line of the pit box;
3. The inside rear tire is on or outside the outside line of the pit box;
4. The rear tire(s) is on or rearward of the back line of the pit box.

9-14.4 Crew Members

A. It is the responsibility of the crew members, not ARCA, to ensure that he / she maintains, wears and properly uses protective clothing and equipment during racing conditions in accordance with Section 17 Personal Safety Equipment.

B. The only personnel that are permitted in the pit box or pit service area (over the wall) will be those who are properly licensed, credentialed and equipped/attired during racing conditions.

C. Crew members must not go on the race track for any reason while the vehicles are racing or while the vehicles are running under the yellow flag or the red flag, unless directed to do so by an ARCA Official.

D. It is the responsibility of the crew chief to prevent all crew members from servicing the vehicle, until the vehicle is within its assigned pit box or pit service area.

E. A crew member's foot must not touch the pit road surface before the vehicle is one (1) full pit box or pit service area away from its assigned pit box or pit service area or equivalent distance.

F. At all ARCA Menards Series Events, a maximum of four (4) pit crew members will be permitted in the pit box or pit service area during a Modified live and/or Break

pit stop and a maximum of six (6) pit crew members will be permitted in the pit box or pit service area during a live pit stop unless otherwise authorized by ARCA Officials.

G. Must not allow a tire(s)/wheel(s) to cross the center of pit road at any time.

H. Any crew member interfering with another crew's pit stop, causing the other team to incur a penalty or not, may incur a penalty.

9-14.5 Fueler / Catch Can

A. It is the responsibility of the Fueler and Fuel Handler, not ARCA, to ensure that he/she maintains, wears and properly uses protective clothing and equipment during racing conditions in accordance with Section 17 Personal Safety Equipment.

B. Only one Fueler with one fuel can is permitted in the vehicle service area.

C. The Fueler must be in control of the fuel can at all times when fuel is being added to the vehicle.

D. The Fueler will not be permitted to perform any adjustments or other pit stop procedures while the fuel can coupler is engaged with the vehicle-mounted adapter.

E. When refueling, one (1) of the crew members must catch any overflowing fuel into an ARCA-approved overflow container coated red, unless a closed loop system is used. The fuel overflow crew member must be in position to catch any overflowing fuel and be in contact with the overflow container at all times when fuel is being added to the vehicle.

F. Fuel filler cans, overflow containers or any other equipment must not be tossed/thrown at any time.

G. Crew Members will not be allowed to change tires and engage the fuel can at the same time.

9-14.6 Damage Repair

A. All major vehicle repairs, including suspension parts, components and front springs, as determined by ARCA Officials, must be performed behind the pit service wall or in the garage area.

B. After repairs have been completed by the crew, the vehicle is subject to visual or other inspection by ARCA Officials prior to and/or during any further competition.

C. If ARCA Officials determine that further repairs are warranted, the crew must make those repairs on pit road or after removing the vehicle from pit road, depending on the extent and nature of the work required.

D. At the sole discretion of ARCA Officials, a damaged or wrecked vehicle that has been repaired may compete with damaged or missing body panels, vehicle parts and/or other components.

9-14.7 Pit Road Equipment

A. All equipment used to service the vehicle must remain in the assigned pit box or pit service area.

B. When a vehicle runs completely over or under its air hose or over any other equipment within its assigned pit box or pit service area, the driver may be instructed to return to the vehicle's assigned pit box or pit service area for inspection at the direction of ARCA Officials.

9-14.8 Air Tanks

A. Air supply tanks and pressure regulators for all air wrenches must remain on the equipment side of the pit service wall at all times.

B. Air supply tanks must have a protective cage or guard around their regulators and fittings at all times.

9-14.9 Air Wrenches

A. Only two (2) ARCA-approved 1/2-inch drive air wrenches, with a single socket and with a hex design capable of removing or attaching one (1) lug nut at a time, must be used to change tire(s)/wheel(s) during any pit stops.

B. Before the vehicle leaves its assigned pit box or pit service area, the air wrench used to change the front tire(s)/wheel(s) must be carried back to the pit service wall.

C. Electric impact guns will be permitted for use during break Events only.

9-14.10 Jack

A. Only one (1) ARCA-approved jack can be used for a pit stop involving tire(s)/wheel(s) changes.

B. The same jack must be used when tire(s)/wheel(s) are changed on the left and right side during the same pit stop.

9-14.11 Wheels and Tires

A. All tires and wheels must be installed in a safe and secure manner at all times during the Event.

B. A vehicle may be required to report to its assigned pit box/service area to inspect for any improperly installed tire/wheel.

C. Tire usage for the Event will be provided on the Event Entry Blank.

SECTION 10 - EVENT PROCEDURE (FLAG/LIGHT RULES)

10-1 Flag & Light Rules

A. ARCA Officials will use flags/lights, as set forth in this Section providing drivers with information while on the race track during the Event.

B. A driver is considered to have received notice when the flag is raised above the top railing of the flag stand, or when the lights are illuminated, regardless of whether or not the driver has seen the flag/lights.

C. If a driver or crew chief is informed of a decision or circumstance by ARCA Officials in a manner other than by use of flags/lights, then, use of a flag/light in that situation is not necessary.

D. The procedure for use of flags/lights by ARCA Officials may vary for individual tracks or Races.

10-2 Flags

10-2.1 Green Flag

A. The green flag signifies the start or restart of racing conditions. The ARCA Officials will signify "one (1) lap to go", a lap before the green flag will be displayed.

B. At the initial start of the race, the starter will display the green flag at his/her discretion.

C. Once the green flag is displayed on a start or restart, all vehicles must maintain their respective track position/lane as designated by ARCA Officials.

D. At the initial start of the Race the number two (2) starting position must not beat the number one (1) starting position to the start/finish line.

E. All restarts shall be made at a designated location on the race track and will be made known to the drivers in the driver, spotter and crew chief meeting.

F. The leader of the Race will control the restart and must maintain pace to ARCA's discretion within the designated location on the race track.

G. If the leader does not restart when he/she reaches the designated point on the race track, the starter will restart the race.

10-2.2 Blue Flag with Diagonal Yellow Stripe

A. The blue flag with a diagonal yellow stripe signifies that faster traffic is overtaking the vehicle(s) being signaled.

B. Vehicles being given this flag must prepare to yield to overtaking traffic.

10-2.3 Yellow Flag / Caution Lights

A. When the caution lights are illuminated and/or the yellow flag is displayed this will signify a caution period. The yellow flag will be displayed, and the caution lights illuminated immediately following the cause for the caution period.

B. ALL DRIVERS MUST REDUCE THEIR VEHICLE'S SPEED TO A CAUTIOUS PACE, maintaining their respective track position independently while forming and maintaining a single line behind the lead vehicle.

C. Vehicles must maintain, under their own power, a reasonable speed considering the conditions that exist on the race track. Determination of a reasonable speed is a judgment call and will be made by ARCA Officials.

D. Vehicles returning to the race track from pit road during a caution period must wait for the end of the continuous line of vehicles behind the caution vehicle, unless otherwise directed by ARCA Officials.

E. Any driver who, in the judgment of ARCA Officials, intentionally causes or attempts to cause a caution period by stopping or spinning out or any other action, will be penalized at ARCA's discretion.

F. Vehicles may not pass the caution vehicle unless directed to do so by an ARCA Official. Any vehicles illegally passing the caution vehicle or Race leader will be black-flagged or re-positioned at the discretion of the ARCA Officials.

Freeze the Field: Upon display of caution, all vehicles must slow down and hold position (no passing) and allow pace vehicle to pick up race leader as determined and made known in the driver, spotter and crew chief meeting,

10-2.4 Pit Entry - Closed

A. The pit road will be considered closed at the same time the caution period begins.

B. A pit entry ARCA Official stationed at or near the entry onto pit road will signal that pit road is closed.

C. The pit entry/closed flag (red flag with the yellow cross) will be displayed at the same time the yellow flag is displayed and/or the caution lights are illuminated.

D. Any vehicle(s) having entered pit road before the pit entry/closed flag (red flag with the yellow cross) is displayed, while entering pit road, will be considered to be under green flag pit road conditions.

E. When a vehicle is in the de-acceleration zone and approaching the pit road entrance, and the yellow flag is displayed and/or the caution lights illuminated while entering pit road; while incurring this circumstance, the vehicle can continue to travel the entire length of pit road without stopping and/or pitting and return to the race track without receiving a penalty for pitting while the pit road is closed. In this

occurrence, the vehicle's position will be determined at pit road exit in relation to those vehicles that remained on the track.

F. Any vehicle entering the pits after the pit entry/closed flag (red flag with the yellow cross) is displayed but prior to the pit entry/open flag (green flag) shall start at the "Tail of the Field" after the one (1) lap to go signal has been given by the starter, regardless of his/her position in the Race.

10-2.5 Pit Entry - Open

A. When the caution vehicle has entered the race track and is positioned in front of the lead vehicle and the Race Director opens pit road, the pit entry ARCA Official will, display the pit entry/open flag (green flag) signifying that all eligible vehicles may enter pit road.

B. The "Free Pass" vehicle will be permitted to pit after being instructed to pass the caution vehicle.

C. ARCA may, because of conditions, limit the entry to pit road.

10-2.6 Free Pass

A. After the yellow flag is displayed and/or caution lights are illuminated, the highest scored eligible vehicle, one (1) or more laps down to the leader at the time of a caution period, will be given one (1) lap back.

B. The vehicle must maintain a reasonable speed (what determines a reasonable speed will be at the discretion of ARCA Officials).

C. The "Free Pass" vehicle will be permitted to pit after being instructed to pass the caution vehicle. The "Free Pass" vehicle will pit with lapped cars. Fuel may only be added the first time the vehicle is eligible to pit.

D. A vehicle is not eligible to receive the "Free Pass" when, in the judgment of ARCA Officials, the vehicle was involved in, or the reason for the caution. Under these circumstances, the "Free Pass" will not be awarded to any car.

E. If a vehicle is under penalty by ARCA, the vehicle is in the garage, the vehicle is behind pit wall, making a pit stop before pit road is open, or making a pit stop before being eligible the vehicle will be deemed ineligible to receive the "Free Pass" and the "Free Pass" will be awarded to the next eligible vehicle.

10-2.7 Wave Around Vehicle Determination

A. All vehicles between the leader and the caution vehicle at the start/finish line when the "one to go" signal is given by the starter are considered "Wave Around" eligible.

B. "Wave Around" vehicles must cross the start/finish line under the green flag on the race track before being permitted to enter pit road without a penalty.

C. Vehicles under a penalty and/or the "Free Pass" vehicle will not be eligible to receive a "Wave Around".

10-2.8 Red Flag

A. THE RED FLAG SIGNIFIES THAT THE PRACTICE, QUALIFYING OR RACE MUST BE STOPPED IMMEDIATELY REGARDLESS OF THE POSITION OF THE VEHICLES ON THE RACE TRACK.

B. The red flag shall be used if, in the opinion of ARCA Officials, the Practice, Qualifying or Race should be stopped immediately.

C. Vehicles should be brought to a stop in an area designated by ARCA Officials.

D. Except for the scheduled breaks, repairs or service of any nature or refueling will not be permitted when the Race is halted due to a red flag.

E. All work must stop on any vehicle in the pits and/or garage area when the red flag is displayed during the Race, unless the vehicle has withdrawn from the Event by the crew chief. Work must not be resumed until the red flag is withdrawn.

F. Failure to follow the procedures as set forth in this Section may result in the vehicle being parked for the remainder of the race, at the discretion of the Series Director.

10-2.9 Black Flag

A. The black flag signifies the driver must go to the pits immediately and report to the ARCA Official at the vehicle's assigned pit box or pit service area, it does not mean automatic disqualification.

B. In addition to the black flag, ARCA Officials may use a blackboard or black flag number indicator in full view of the Competitor on which the number of the vehicle being black-flagged will be displayed.

C. ARCA Officials may also communicate to the crew chief or designated spotter the black flag directive.

10-2.10 Black Flag with White Cross

At the discretion of the ARCA Officials, if the driver does not obey the black flag directive, the driver may then be given the black flag with a white cross at the start/finish line to inform the driver that any additional scoring of his/her vehicle will be discontinued until further notice.

10-2.11 White Flag

A. The white flag signifies that the lead vehicle has started its last lap in the Race.

B. At select tracks that have a single attempt overtime finish, if the caution lights are illuminated and/or yellow flag is displayed during the white flag lap, vehicles will be scored based on their respective track position. **NO PASSING WILL BE PERMITTED** as long as the vehicles maintain a reasonable speed considering the conditions that exist on the race track. The determination of respective track position and reasonable speed are judgment calls that will be made by ARCA Officials.

C. In the judgment of ARCA Officials, vehicles may not receive assistance after the lead vehicle has received the white flag at the start/finish line, except vehicles making a pit stop. A violation will result in the vehicle not being scored on that lap.

D. In the judgment of the Race Director, the vehicle or team providing the assistance after the lead vehicle has received the white flag at the start/finish line may be subject to a post-race lap(s) or time penalty and scoring correction.

10-2.12 Checkered Flag

A. The checkered flag signifies that the Race is completed.

B. When the required Race distance has been completed by the lead vehicle, the Race distance will be declared "officially complete" regardless of the flag being displayed. The definition of the required Race distance is provided in sub-section 9-13 Official Completion.

C. When the checkered flag is displayed and the lead vehicle completes the Race, the balance of the field also completes the Race in the same lap. Finishing positions will be determined according to the most laps traveled in the least total time, whether the vehicle is still running or not.

D. The Race winner or any other designated Race finisher(s) in the Race must bring his/her vehicle to the start/finish line or designated area and remain there until released by the ARCA Official.

10-2.13 Special Flags / Signal Lights

A. Special flags and/or signal lights may be used at the discretion of ARCA Officials and will be explained at the driver, spotter and crew chief meeting.

B. ARCA will display the black flag and red flag together to inform the Competitors of the end of practice. All vehicles must report to the pit road or garage area.

C. At road course Events, special flags may be used and explained at the driver, spotter and crew chief meeting.

SECTION 11 – TIMING AND SCORING

11-1 Official Scoring

A. ARCA will designate the Chief Scorer for an Event. The Chief Scorer is responsible for timing and scoring all Competition activities during the Event.

B. The decisions of the Chief Scorer, with respect to timing and scoring, are final unless there is a request for a scoring audit in accordance with Section 11.2 Scoring Review/Audit Procedure.

11-2 Scoring Review / Audit Procedure

A. ARCA will post the unofficial scoring results after the completion of each Competition activity, at the Series Hauler. A Competitor will have 20 minutes from the time unofficial results are posted to evaluate and/or request a review of the unofficial results to the Chief Scorer.

B. At the discretion of ARCA, or at the request of a Competitor, the Chief Scorer will review the scoring results for the Competition and will make any corrections to the scoring results as deemed appropriate including, but not limited to, correcting missed or extra lap(s) or time penalties pursuant to sub-section 9-10 Lap or Time Penalties. In the event that any corrections are made, Competitors will have an additional 20 minutes to evaluate and/or request a review of the adjusted scoring results once posted.

C. The Chief Scorer will explain any adjustments made to the scoring results and answer inquiries from the Competitor, as a part of this review. Upon completion of the review, the Chief Scorer will again post the unofficial results.

D. The scoring results of the Event, including any individual Race, Qualifying session(s) or Qualifying Race(s), will be considered official once the Competitors' 20 minute evaluation window has expired, provided no audit is requested by ARCA as provided herein, in which case the scoring results of the Event shall be considered official upon the announcement of the audit decision by ARCA Officials.

E. If the Chief Scorer independently requests an audit of the timing or scoring of an Event, the request and any scoring data for the Event will be forwarded to the Director of Timing and Scoring.

F. ARCA reserves the right to further amend or adjust the official results at any time as a result of procedural circumstances in accordance with these Rules (e.g. as a result of Penalties, Appeals decisions, protest, etc.

SECTION 12 – VIOLATIONS AND DISCIPLINARY ACTION

12-1 General Procedure

A. If ARCA observes or is made aware of an act or omission by an ARCA Member that constitutes a violation of the ARCA Rules or that is detrimental to stock car racing or ARCA, and if ARCA determines that the act or omission is sufficiently serious to warrant the imposition of a Penalty, the Official shall report the violation to the Supervisory Official as soon as practicable, recommending the Penalty for the violation.

B. The Member shall be informed of the determination by the Supervisory Officials, and if disciplinary action is imposed, the Director of Race Operations and Administration shall cause a Penalty Notice to be issued to the subject Member specifying the violation, a brief statement of the time and circumstances of the violation, and the Penalty imposed.

C. ARCA may publish notice of the violation and the Penalty.

D. The subject Member referenced in the Penalty Notice shall have no claim or cause of action of any kind against ARCA and its Members, Employees and Affiliates, or any individual publishing such Penalty Notice or announcing the violation.

E. If the Member wishes to appeal the Penalty Notice, the Member shall make a written request for a hearing to the Department of Appeals within three (3) business days of the issuance of the Penalty Notice as outlined in Section 14 Appeals.

12-2 Emergency Action

A. If the act or omission of a Member is determined by ARCA to constitute a threat to the orderly conduct of the Event, ARCA may take temporary emergency action against the Member. Such emergency action may include ejection from the racing premises, suspension of membership and license, or any other action designed to remove the threat created by the Member.

B. Examples of conduct warranting such emergency action include, but are not limited to, the consumption of alcoholic beverages, stimulants, depressants, tranquilizers or other drugs before or during an Event, the use of illegal drugs at any time, fighting, reckless driving, Rules violations, Race procedure violations, or any other directive of an Official.

C. That ARCA Official shall report the Member's conduct, and the emergency action taken, to the Supervisory Official as soon as practicable, and thereafter the procedure set forth in sub-section 12-1 General Procedure shall apply.

D. The emergency action shall remain in effect until the decision of the Supervisory Official is made, except that parking and/or an ejection is final, non-appealable and non-reviewable in accordance with sub-section 3-10 Ejection and/or sub-section 9-12 Parking.

12-3 Payment of Fines

A. Fines shall be paid to ARCA Headquarters promptly after receipt of a Penalty Notice.

B. All unpaid fines assessed against any Car Owner, driver or team member must be paid in full before their entry can be considered for acceptance.

C. Failure to pay any outstanding fines in a timely manner may result in suspension.

D. All unpaid fines of a Member may be collected by ARCA by deducting the amount from the purse or point fund earnings of the Member, or if the Member is not a driver, from the purse or point fund earnings of the driver or Car Owner with whom the Member was associated at the time of the conduct that gave rise to the Penalty Notice.

E. Any fines left unpaid at the end of the racing season shall be considered grounds for refusal to approve that Member's ARCA membership application for the next applicable year of the Member against whom the unpaid fine has been assessed.

12-4 General Scope of Penalties (The ARCA Deterrence System)

A. ARCA may issue Penalties as it deems fit to provide for the orderly conduct of the sport.

B. The ARCA Deterrence System exists to help maintain the integrity of the sport, maintain a competitive but balanced playing field, send a clear message to the garage and the industry that Rules violations will not be tolerated, address safety for all involved, and provide for the best possible motorsports experience for fans, sponsors, supporters, and participants.

C. Penalties are designed primarily to deter ARCA Rules violations. As with every professional sport, Penalties must serve as both a deterrent and a punishment.

D. When ARCA determines that it must issue a Penalty, it will refer to the guidelines described in this Section and past precedent.

12-5 ARCA Deterrence System

To treat all members fairly and equitably, among other things, the ARCA Deterrence System provides for Penalties:

- Without regard to intent or lack of intent in the case of technical infractions.

- Without attempting to determine if any perceived advantage or disadvantage may have resulted from a technical infraction.
- Without attempting to determine who was actually a party to whatever led to the violation, except in the case of behavioral infractions, and then only to the extent reasonable and practical for a sporting authority.
- Without regard to a driver or team's current position in the Championship point standings.
- Without regard to a member or team's financial means or current manpower resources.
- Without regard to the manufacturer, sponsor, supplier, vendor, or any third-party affiliates.

12-5.1 Guiding Principles Relative to Penalties

A. Some guiding principles relative to Penalties that are issued for technical infractions include:

- Any infraction that was undetected during any prior inspection(s) is still an infraction regardless. In most cases, however, ARCA will not retroactively issue a separate Penalty for previous Events that occurred prior to the competition in which the infraction was detected, except in circumstances such as where components may have been sealed, etc.
- The responsibility for full compliance with the Rules on or of any and all elements provided by, leased, purchased, etc. by third-party suppliers, and/or from other affiliated race teams or former race teams lies solely with the team that has entered the vehicle in competition.
- Any element(s) that constitute Rules infractions may be confiscated by ARCA. ARCA will address requests for the return of confiscated elements on a case-by-case basis.

B. The issuance of a Penalty by ARCA is not a reflection on any sponsor affiliated with an affected team, driver, or Member; nor on the racing organization that fielded the race vehicle; nor on any of the individuals employed by that organization; nor on the auto manufacturer; nor on those who were specifically named in the Penalty.

C. A Penalty issued under the scope of this Section may be appealed as outlined in Section 14 Appeals and further appealed under Section 15 Final Appeal to the Final Appeals Officer. Both the Appeals Panel, upon the initial hearing, and the Final Appeals Officer, if on further appeal, are empowered to modify a specific Penalty Notice that was issued under this Section if they determine that the specific circumstances of the infraction(s) under their review warrant such modification. However, neither the Appeals Panel nor the Final Appeals Officer are empowered to re-run any Event, or to re-write any Rules in this Rule Book, or to re-write this General Scope of Penalties. Only ARCA has the authority to re-write the Rules in the Rule Book.

D. The ARCA Deterrence System has evolved over many years. Accordingly, Penalties that were issued in the past have factored into the evolution of the current ARCA Deterrence System. Be advised however that, if ARCA determines that a Penalty should be issued for an infraction, it will use the current General Scope of Penalties (the ARCA Deterrence System) as outlined in this Rule Book, or as amended from time to time, as the guide.

E. ARCA will review the ARCA Deterrence System from time to time and make adjustments as needed. ARCA welcomes relevant input from any ARCA Member in this regard. However, any decision to adjust this System will be made solely by ARCA. If adjustments are made, ARCA will not retroactively adjust any Penalties that had already been issued.

12-5.2 Recurrence Multipliers

A. Recurrence Multipliers are designed to deter additional Rules infractions by a team and/or Member. A Recurrence Multiplier is assessed on the basis of one (1) or more subsequent infraction(s) occurring with the same registered vehicle number, during a fixed period of time after one (1) or more Penalty Notices had previously been issued, regardless of any owner, driver or crew changes that might have occurred during the interim.

B. The Recurrence Multiplier would also apply to individual crew members and their actions.

C. The Recurrence Multiplier is not affected by any subsequent change in driver or Car Owner but is assigned on the basis of subsequent infractions with the same registered vehicle number. Approved vehicle number changes or reassignments do not negate or eliminate applicability of the Recurrence Multiplier.

D. When the amount of a fine, loss of points, period of suspension and/or probation is increased due to a Recurrence Multiplier, point deductions are assessed regardless of the current points total that the driver or Car Owner may have accumulated to that point in the season, if any.

12-5.3 Determinations of Warnings and Penalties

The following structure generally describes the ARCA Deterrence System that ARCA uses as a guideline when determining Warnings and Penalties.

12-5.3.1 Warning Options

A. When appropriate, ARCA will issue a Warning instead of a Penalty for certain types of minor infractions. The purpose of the Warning and nature of the infraction will be provided to the team. Warnings are not appealable.

B. ARCA considers the accumulation of Warnings to be unacceptable and may result in loss of track time or qualifying.

12-5.3.1.1 P1 Penalty Options

When appropriate, ARCA will issue a P1 level Penalty for certain types of ancillary infractions which are typically of a nature related to the singular actions or omissions of an individual during an Event. These violations tend to pertain to unsafe or improper use of apparel or equipment and other minor violations.

12-5.3.1.2 P1 Violation Examples

A P1 Penalty is a violation of a lesser nature or what is considered to be a minor violation including but not limited to:

1. A vehicle fails a qualifying inspection discipline twice or more at the same Event or a pre-Race inspection discipline twice or more at the same Event.
2. Failure by the driver or crew members to properly wear or secure mandatory safety apparel or equipment (i.e. head socks, under garments, helmet face shields, shoes, gloves, etc.) in accordance with the ARCA Rules.
3. Approved parts that do not meet minimum material thickness (such as drive shafts, A-frames, etc.).

12-5.3.1.3 Minimum P1 Penalty Options

Minimum P1 Penalty options (ONE (1) OR MORE of the following may be used):

1. Issuance of a Warning.
2. Probation through the end of the calendar year for the crew chief, or for a six (6) month period following the issuance of the Penalty Notice if that period spans across two (2) consecutive seasons.
3. Up to \$1,000 fine, depending on the specific infraction.
4. Loss of six (6) Championship driver and six (6) Championship owner points, irrespective of whether it was a Championship race or not.
5. Suspension for the crew chief, and/or any other team members, as determined by ARCA.

12-5.3.2 P2 Penalty Options

The Penalty includes the combination of ALL minimum elements listed below.

A. Violations leading to P2 Penalties, in general, are very serious.

1. Parts which do not meet specifications;
2. Unauthorized parts that differ from what had been approved;
3. Actions or omissions which might circumvent the Rules; mounting configurations which might represent a safety compromise;
4. Failure to meet go/no-go measurements, and measurement failures of significance.

B. These often involve primary component or system infractions not otherwise rising to the magnitude of P3 infractions, but could also include secondary component or system infractions, particularly if of a nature suggesting some of the characteristics described in P3 below, and/or involving safety implications.

12-5.3.2.1 P2 Penalty Violation Examples

Violation examples could include but are not limited to:

1. Unapproved body modifications.
2. Engine components (i.e.; fly wheel, etc.) that differ from what is required by the Rule Book (i.e.; original source if specified; material; configuration; alteration in areas not permitted; etc.).
3. Approved parts that fail their intended use (e.g.; shock absorbers that fail to rebound regardless of reason).
4. Anything which would circumvent mandated regulatory devices such as pre-determined gear rule.
5. Loss or separation of ballast weight from the vehicle.

12-5.3.2.2 Minimum P2 Penalty Options

Minimum P2 Penalty (the Penalty may include ALL four (4) points below):

1. Loss of up to 12 Championship driver and 12 Championship owner points, irrespective of whether it was a Championship race or not.
2. Up to \$2,500 fine.
3. Suspension for the next series Championship race, plus any non-Championship races or special Events which might occur during that time period, for the crew chief and any other team members as determined by ARCA.
4. Probation through the end of the calendar year, or probation for a six (6) month period following the issuance of the Penalty Notice if that period spans across two (2) consecutive seasons.

12-5.3.3 P3 Penalty Options

The Penalty may include the combination of ALL minimum elements listed below:

Violations resulting in P3 Penalties, in general are extreme, and also represent the expressly-forbidden areas of unauthorized activity such as violation of the ARCA Testing Policy or in the race vehicle, including the internal workings and performance of the engine; Certified Race Equipment (including maintaining the integrity of the encryptions or ARCA certification verification(s)), Approved Chassis, including major safety systems designed to protect the driver, other competitors and fans; and other significant items such as technologies or evidence of technologies like nitrous oxide or traction control.

12-5.3.3.1 P3 Penalty Violation Examples

Violation examples could include but are not limited to:

1. Effecting, modifying and/or altering the standard tires in any way.
2. Effecting, modifying and/or altering the standard fuel in any unauthorized manner.
3. Any unapproved modification to the approved chassis without prior notice to and approval by ARCA, such as failing to meet minimum wall thickness of the frame and/or roll bars.

12-5.3.3.2 Minimum P3 Penalty Options

Minimum P3 Penalty may include a mandatory suspension as described below:

1. Suspension for the next three (3) series Championship races, plus any non-Championship races or special Events which might occur during that time period, for the crew chief and any other team members as determined by ARCA;

As an option, a P3 Penalty may also include any or All three (3) points below:

1. Loss of 100 Championship driver and 100 Championship owner points, irrespective of whether it was a Championship race or not.
2. Up to \$5,000 fine.
3. Probation through the end of the calendar year for all suspended members, or for a six (6) month period following the issuance of the Penalty Notice if that period spans across two (2) consecutive seasons.

12-6 Penalty Notice

A. The Penalty Notice will state which ARCA Member(s) receive which portion of a given Penalty relative to a given vehicle number for technical infractions.

B. Generally, Championship Car Owner points will be deducted from the Car Owner of record; Championship driver points will be deducted from the starting driver; fines will be assessed against the crew chief of record; suspensions and/or probation for technical infractions will be assessed against the crew chief and/or other crew members. Applicable special award points will be deducted.

12-7 Suspension

A. A suspension may be total or it may be limited to a suspension of membership and/or license privileges at a particular track or tracks, and/or for a particular series of Events, and/or for one (1) or more ARCA-sanctioned Events, and/or for a specified or indefinite period of time, and/or as otherwise determined by ARCA.

B. Any special conditions for the suspension will be stated on the Penalty Notice.

C. All suspensions are with immediate effect.

D. In general, a Member who is suspended is not eligible to participate in person in any ARCA-sanctioned activity, nor to enter restricted areas of an Event (e.g. garage, pits, spotter stand, victory lane, etc.) in which the competition or related activities take place.

E. If the Member holds a current ARCA License or current ARCA annual credential, that License or credential shall not be valid during the period of suspension.

F. Other ARCA privileges will be suspended during the period of suspension. However, during the period of suspension, the Member is still bound by and subject to this Rule Book and all the obligations of a licensed ARCA Member.

12-8 ARCA Member Conduct

A. ARCA membership is a privilege. With that privilege comes certain benefits, responsibilities and obligations. Correct and proper conduct, both on and off the race track, is a part of a Member's responsibilities. A Member's actions can reflect upon the sport as a whole and on other ARCA Members. Ideally, ARCA Members are role models for the many fans who follow this sport, regardless of the type of license a Member may hold, or the specific Series in which a Member may participate. Therefore, ARCA views a Member's conduct, both on and off the race track, which might constitute a behavioral Rules violation under this Rule Book with great importance.

B. A Penalty issued for technical infractions are often based on exact technical measurements, tolerances and/or written specifications. However personal actions or omissions, other than behavior by a Member that might give rise to the issuance of a Penalty under Section 12 Violations and Disciplinary Action, are usually not.

C. In part, due to their individual nature, and the context in which they may have

occurred, behavioral infractions do not lend themselves to a structure. However, when reviewing and making a determination about the more common behavioral actions that have arisen from time to time, ARCA will generally refer to the Member Conduct Guidelines in this Section with regards to issuing a Penalty Notice or taking other action.

D. ARCA expects Members to police their own behavior, attempt to resolve disputes with other Members, and generally act as a role model representing the sport. ARCA, in its sole discretion, may call mandatory meetings with Competitors, and meetings may also be requested by Competitors. However, from time to time, a Member's action or omission may give rise for the need for ARCA to step in, review the matter, and if necessary, take action to maintain the fairness of Competition and/or the integrity of the sport. This might include Race Procedure decisions under Section 9 Event Procedure, issuing a Penalty Notice under Section 12 Violations and Disciplinary Action, or both.

E. ARCA Members shall not make or cause to be made a public statement and/or communication that criticizes, ridicules, or otherwise disparages another person based upon that person's race, color, creed, national origin, gender, sexual orientation, marital status, religion, age or handicapping condition.

F. ARCA acknowledges that the nature of the sport of stock car racing involves hard and sometimes aggressive racing while contesting a position that could result in routine racing contact. If deemed as such, these are instances that would not normally result in further action by ARCA.

G. In extraordinary circumstances, ARCA may take whatever action it deems necessary to mitigate and/or rectify circumstances created by a Member's actions including, but not limited to, negating the results of a driver's performance and/or advancing a driver in the standings.

H. Certain behavioral infractions are zero-tolerance (e.g. substance abuse violations) and are described in greater detail elsewhere in the Rule Book. Most behavioral infractions fall under the broader heading of Actions Detrimental to the Sport.

I. ARCA will generally refer to the following Member Conduct Guidelines when determining if any official action is required and, if so, what the scope of a Penalty Notice might include in most corresponding cases.

12-8.1 Member Conduct Guidelines

A. Member action(s) that could result in enforcement actions ranging from meeting, warning, probation; loss of points; monetary fine; and/or suspension listed in order of severity:

1. Heat-of-the-moment actions or reactions, either on or off the race track;
2. Member-to-Member confrontation(s) without physical violence (e.g. shoving match, or general "venting").

B. Member actions that could result in a \$300-\$1,000 fine and/or probation:

1. Disparaging the sport and/or ARCA's leadership;
2. Verbal abuse of an ARCA Official, media members, fans, etc.;
3. Intentionally damaging another vehicle under yellow or red flag conditions or on pit road with no one around.
4. Failure to complete media obligations as outlined in the applicable Driver and Car Owner agreements.
5. Failure to comply with ARCA's COVID-19 Protocol Guidelines and/or instructions from ARCA including screenings, social distancing, compartmentalization and use of required personal protective equipment, etc.

C. Member actions that could result in a loss of 6-12 Championship driver and car owner points and/or \$1,500-\$2,500 fine and/or one Race suspension, indefinite suspension, or termination:

1. Physical confrontation with an ARCA Official, media members, fans, etc.;
2. Member-to-Member confrontation(s) with physical violence and other violent manifestations such as significant threat(s) and/or abuse and/or endangerment;
3. Attempting to manipulate the outcome of the Race or championship;
4. Intentionally wrecking another vehicle, whether or not that vehicle is removed from Competition as a result.

D. Member actions that could result in a loss of 20-100 Championship driver and car owner points and/or \$3,500-\$5,000 fine and/or two Race suspension, indefinite suspension or termination:

1. Targeting another driver who is in a highly vulnerable position, such as already stopped with window net lowered; or whose vehicle has already had one or more of its safety systems affected by crash damage, such as an exposed fuel cell, damaged roll cage, and so on.

2. Premeditatedly removing another Competitor from championship contention in a dangerous manner when not racing for position based on the available evidence and specific circumstances of the incident.

- Without limiting the scope, examples could include a Competitor "waiting" for another Competitor and then taking action; taking a trajectory with the vehicle not normally taken such as from pit exit

directly up into a vehicle in the racing groove; clearly forcing another Competitor into the wall in an abrupt and unambiguous manner; and so on.

E. Member actions that could result in a fine and/or indefinite suspension, or termination:

1. Actions by an ARCA Member that ARCA finds to be detrimental to stock car racing or ARCA.
 2. Statement and/or communication made public (including social media platforms) that demeans, criticizes, ridicules, or otherwise disparages another person based upon that person's race, color, creed, national origin, gender, sexual orientation, marital status, religion, age, or handicapping condition.
 3. Being charged with or convicted of significant criminal violations (e.g. Domestic Violence, Trafficking, Assault), or having had determinations rendered by criminal or civil authorities that in ARCA's judgement necessitate action. ARCA will not pre-judge guilt or innocence in the criminal or civil legal system, or the guilt or innocence of the Member, but rather review each matter in its own context and circumstances and with regards to its potential effects upon the sport.
 4. Violation of ARCA's Sports Gambling Policy.
- F. Factors that ARCA may consider when reviewing a matter might include:
1. When and where the incident(s) occurred;
 2. The perceivable or potential ramifications to others and/or to the sport;
 3. Available empirical data;
 4. Member's past history;
 5. Possible effects to fans, safety workers, crew members;
 6. Any extenuating circumstances;
 7. Was the explanation(s) plausible given the circumstances;
 8. Was there an indication of genuine remorse or attempts to work things out with the other party(s) in a civil manner: and so on.

12-9 ARCA Sports Gambling Policy

All ARCA Members have an obligation to protect the integrity of the sport. Gambling on NASCAR/ARCA Events by Members can pose a serious threat to the integrity of NASCAR/ARCA, its stakeholders, and the industry as a whole. The integrity of NASCAR/ARCA Competition remains our greatest asset. To protect the sport from corrupt influences, ARCA's Sports Gambling Policy is outlined in this Section.

12-9.1 ARCA Members Subject to Sports Gambling Policy

A. While ARCA reserves the right to regulate any ARCA Member gambling conduct related to NASCAR/ARCA Events, ARCA has an enhanced concern regarding the conduct of Competitors who actively compete and contribute to the on-track NASCAR/ARCA Competition. As such, ARCA's Sports Gambling Policy applies to ARCA Competitors holding the following valid ARCA Series licenses:

- Competition – Driver
- Competition – Team Owner
- Competition – Crew Member
- ARCA Official

B. ARCA reserves the right to pursue legal or disciplinary action or to terminate one's membership based on gambling conduct even if the given individual is not listed in this Section.

12-9.2 Sports Betting

A. ARCA Members shall not engage, nor attempt to engage, in any legal or illegal gambling activity (as defined below) relating to any Event:

- In which NASCAR/ARCA is involved, including but not limited to, the NASCAR Cup Series, NASCAR Xfinity Series, NASCAR Craftsman Truck Series, and/or eNASCAR esports, or
- That in the judgment of ARCA could represent the potential for a conflict of interest, unsportsmanlike conduct, or other action(s) detrimental to stock car auto racing or NASCAR/ARCA.

This Rule applies to all gambling activities, including without limitation, those available in any gaming facility, casino, lottery gaming facility, Race track gaming facility, on the internet or electronically, or in all other establishments and locations. Gambling activity, for purposes of the above, is defined as placing anything of value at risk, financial or otherwise, in connection with a bet, wager, or Game of Chance.

B. ARCA Members shall not instruct, cause, or enable other individual(s) to engage, or attempt to engage, in any legal or illegal gambling activity on an Event, as defined above, nor should they accept any money or other thing of value stemming from another individual's legal or illegal gambling activity on an Event.

C. ARCA Members shall not engage, nor attempt to engage, in any legal or illegal gambling activity relating to any off-track or other occurrences, actions, or proceedings concerning or related to NASCAR/ARCA or its business, including but not limited to, team/driver signings, Race locations, disciplinary matters, eNASCAR

esports participation or other proposition bets, nor should they accept any money or other thing of value stemming from another individual's legal or illegal gambling activity on any off-track occurrences.

D. ARCA Members shall not instruct, cause, or enable other individual(s) to engage, or attempt to engage, in any legal or illegal gambling activity relating to any off-track or other occurrences, actions, or proceedings, as defined above.

E. ARCA Members shall not promote any gambling sportsbooks that are not in compliance with all applicable laws and regulations relating to sports gambling within the United states.

12-9.3 Fantasy Games

A. Fantasy games, daily fantasy games, or free to play contests or any similar online contests in which the real-world performance of NASCAR/ARCA Competitors determines the virtual performance and/or point total of a fictional racing team assembled by game participants, are defined as Games of Skill rather than gambling activity.

B. ARCA Members are permitted to engage in daily and/or season long fantasy games or free to play contests relating to any Event in which NASCAR/ARCA is involved, including but not limited to, the NASCAR Cup Series, NASCAR Xfinity Series, NASCAR Craftsman Truck Series, and/or eNASCAR esports Events, but shall not accept except prizes with a value in excess of \$250 (two hundred fifty dollars) total in any such fantasy games over the course of the NASCAR/ARCA season, nor should they accept any money or other thing of value stemming from another individual's legal or illegal gambling activity on any off-track occurrences.

12-9.4 Fixing / Bribing / Collusion

A. ARCA Members may not be involved with the offering, giving, acceptance or receipt of a bribe, gift, or any type of consideration, financial or otherwise, that could improperly influence, manipulate, or fix an Event:

- In which NASCAR/ARCA is involved.
- That in the judgment of ARCA could represent the potential for a conflict of interest, unsportsmanlike conduct, or other action(s) detrimental to stock car auto racing or NASCAR/ARCA.

B. ARCA Members may not participate in nor instruct, cause, or enable other individual(s) to engage in any on-track or off-track action that could improperly influence, manipulate, or fix an Event, as defined above.

C. ARCA Members must give their honest and best efforts when competing in ARCA Events and shall not engage, nor attempt to engage, in any intentional underperformance regardless of purpose, motivation, or incentive.

12-9.5 Tipping / Divulging of Information

A. ARCA Members shall not directly or indirectly disclose, nor attempt to disclose, to any other individual or entity confidential information, information which the ARCA Member has obtained by virtue of his or her position within the racing industry, or any other non-public special knowledge or information for the purposes of enabling or facilitating gambling activity related in any way to Events in which NASCAR/ARCA is involved or off-track actions.

B. ARCA Members shall not request or support, nor attempt to support, any such provision of knowledge or other information, whether for their own gain or for the gain of others.

C. ARCA Members shall not be involved with any such provision of knowledge or other information in situations where they know, or reasonably should know, that disclosure could contribute to improper use of such information in connection with sports betting.

12-9.6 Reporting Obligation

A. ARCA Members are under a duty to report the following matters to ARCA, without undue delay and unprompted, at the first available opportunity, via compliance@arcaracing.com. or, if circumstances make utilization of compliance@arcaracing.com impractical, by directly reporting such matters to the President of ARCA and/or Managing Director, Touring & Weekly Series:

- Attempted, requested, witnessed, or observed legal or illegal gambling activity or noncompliant involvement with Games of Skill relating to any Event:
 - In which NASCAR/ARCA is involved.
 - That in the judgment of ARCA could represent the potential for a conflict of interest, unsportsmanlike conduct, or other action(s) detrimental to stock car auto racing.
- The offering, giving, acceptance, and/or acceptance or receipt of a bribe, gift, or any type of consideration, financial or otherwise, that could improperly influence, manipulate, or fix an Event, as defined above.
- Attempted, requested, witnessed, or observed disclosure of confidential information, information which an ARCA Member has obtained by virtue of his or her position within the racing industry or any other non-public special knowledge or information for the purposes of enabling or facilitating

gambling activity related in any way to NASCAR/ARCA Events or off-track actions.

- Any activity known, suspected, or anticipated to be noncompliant with the ARCA Sports Gambling Policy.

B. ARCA Members are under a duty to report the above matters to ARCA, without undue delay and unprompted, at the first available opportunity, whether they are directly involved with the matter or should have reasonably been aware of the matter. This provision applies to any ARCA Member who should reasonably be aware of attempted, witnessed, or suspected Rules violations related to affiliated Competitors.

12-9.7 Investigation Obligation

ARCA Members are obligated to cooperate and affirmatively participate in any league investigation of a violation of the Rules whether the investigation stems from a report submitted by that person and/or whether he or she is the subject, witness, or even a person of interest in the investigation.

12-9.8 Disciplinary Action

ARCA reserves the right to issue Penalties to any Member (regardless of license type) for violations of its Sports Gambling Policy under Section 12-8.1 ARCA Member Conduct Guidelines via the procedures set forth in Section 12-1 General Procedure, should the conduct of such Member, in the judgment of ARCA, represent the potential for a conflict of interest, unsportsmanlike conduct, or other action(s) detrimental to stock car auto racing or NASCAR/ARCA.

12-9.9 Competition Reinstatement

A. ARCA shall send the suspended ARCA Member a letter containing the terms and conditions for consideration of reinstatement of the ARCA Member's ARCA license.

B. If the ARCA Member wishes to have ARCA lift the suspension, the ARCA Member must agree to ARCA's terms and conditions.

C. Under the terms and conditions of reinstatement, a designated Program Administrator (PA) will facilitate an evaluation for the Reinstatement Program by coordinating an evaluation with the appropriate professional for advising on creation of a Reinstatement Plan.

D. When an ARCA Member has, to the satisfaction of the PA, completed the requirements set forth in the letter, the ARCA Member is eligible for reconsideration of reinstatement of a ARCA license.

12-10 Other ARCA Penalties

A. ARCA may also issue other types of Penalties as it deems fit for the orderly conduct of the sport that fall outside the scope of this Section. Those include areas such as but not limited to:

1. Race Procedure Penalties issued during the running of a Race (pit road speed violation; pitting outside the box or pit service area; working under a red flag; etc.).
2. Other Event-related Penalties listed on the ARCA Pit Road Procedure Card or elsewhere in this Rule Book (engine change during the Event, etc.).
3. Lap or Time Penalties specified in sub-section 9-10 Lap or Time Penalties.
4. Administrative Penalties (insufficient funds; invalid credit card information; etc.).
5. Penalties issued relative to the Appeals Process (member held "in contempt"; failure to appear and or testify; etc.).
6. Emergency Actions specified in sub-section 12-2 Emergency Actions.

B. Penalties in these areas are not appealable in any case. Only Penalties issued relative to this Section via a Penalty Notice may be appealed.

SECTION 13 - PROTESTS

13-1 General Procedure

A. If a Competitor believes by some action that another Competitor has or will obtain a significant unfair competitive advantage that is in violation of the ARCA Rules, that Competitor may protest such action to the ARCA Supervisory Official.

B. Only a licensed ARCA Car Owner participating in that race event may file a protest.

C. Each individual protested part(s) or component assembly(s) shall be accompanied by a \$1000.00 protest fee.

D. Any person or persons against whom a protest is lodged, shall have the right to file answers to the charges. If a team refuses to tear down the protested item, driver and car owner surrender all prize money and points for that race and subject themselves to immediate and indefinite suspension and/or fine.

E. The tear down area will be determined by ARCA. Two representatives for each car being inspected will be allowed in that area. Anyone else not approved by ARCA entering tear down area is subject to immediate and indefinite suspension and/or fine.

F. Decisions by ARCA Officials at track will be final on any and all protests, except as provided in Section 14 Appeals.

13-2 Matters Not Subject to Protest

Protests will not be accepted that are directed to a decision of an ARCA Official or Supervisory Official on any subject not specifically provided for in these rules. Such subjects include, but are not limited to, timing and scoring decisions (except as set forth in Section 11), inspection decisions and Race procedure decisions.

SECTION 14 - APPEALS

14-1 Right of Appeal

Right of appeal is hereby given to any ARCA member who has been penalized for any infraction of rules, regulations, procedures or specifications of ARCA.

14-2 Appeal Requests

Appeal requests must be in written form (email "compliance@arcaracing.com, fax or courier acceptable) and must be received by ARCA (Attn: Appeals Committee) within three (3) calendar days of penalty notice accompanied with a \$200.00 non-refundable filing fee.

14-3 Appeals Committee Chair Review

ARCA Appeals Committee Chair will review appeal requests. The written appeal must contain the member's specific objection to the penalty. Upon receipt of a timely and complete appeal request and fee, the Committee Chair will convene the Appeals Committee as soon as practical.

14-4 Appearance of Member

Appealing member may appear in person or participate via teleconference in the hearing, but not through a representative or attorney. If the member's appeal is determined to be unsubstantiated, invalid or frivolous, the appealing member may be assessed the cost of proceedings.

14-5 Appeals Committee Decision

Once convened, the Appeals Committee may increase, uphold or decrease the penalty originally assessed by ARCA at its sole discretion.

14-6 Finality of Decision

Decisions made by ARCA Appeals Committee on appeals shall be final and non-litigable except as provided for in Section 15 Final Appeal Officer.

14-7 Appeals Committee

The members of the Appeals Committee for 2024 are:

Harold Cook	John Naida
Jim Leasure	Jeff Nuckles
Keith McCall	Rollo Juckette
Denny McNutt	Jason Sanderson
John Morton	Bill Schneider

SECTION 15 – FINAL APPEAL TO THE FINAL APPEALS OFFICER

15-1 Purpose, Scope and Jurisdiction

A. The duty of the Final Appeals Officer ("FAO") is to provide ARCA Members an impartial opportunity to appeal a decision of the Appeals Panel ("Appeals Panel") from a hearing conducted under Section 14.

B. The FAO has exclusive jurisdiction to:

1. Hear and consider all Appeals Panel decisions regarding any ARCA-issued Penalty Notice which penalizes the Appellant(s); and
2. Hear and consider all Appeals Panel decisions regarding any decision by ARCA to deny, suspend or terminate any ARCA membership.

A specific denial, suspension, or termination of membership may be appealed only once under Section 15 following an Appeals Panel decision under Section 14 and may only be appealed in accordance with the same filing deadline and other stipulations in this Section that pertain to appealing an ARCA Penalty Notice. If a subsequent request for membership or reinstatement of membership for the same matter is again denied by ARCA, such subsequent denial is not grounds for further appeal under Section 14 or Section 15.

C. The scope of each appeal is limited to the correctness of an Appeals Panel's decision from the Section 14 Hearing to the subject matter of the Penalty Notice and/or the ARCA decision in question.

D. Any speculation as to the impact of a Penalty Notice and/or an Appeals Panel decision and/or an FAO decision on a Member or Race Team (e.g., economic

hardships, contractual obligations, etc.) is outside the scope of the FAO's authority and is not to be considered as part of the appeal. All decisions of the FAO will be final and binding on all parties.

E. If for some reason prior to the lapsing of the filing deadline for a final appeal a Member wishes to affirm that he/she will not appeal a given Appeal Panel Decision, then that Member and all parties named in the associated Penalty Notice may formally waive their respective final appeal right.

15-2 Final Appeals Officer

The FAO for 2024 is Rollie Helmling.

15-3 Filing for Final Appeal

A. Once the Appeals Panel has heard an appeal and announced its decision under Section 14, the Appellant(s) shall have the right to appeal the decision to the FAO under this Section 15.

B. The FAO shall be the final appellate authority within ARCA, and an Appellant may appeal any decision of the Appeals Panel to the FAO.

C. ARCA, however, is not permitted to appeal a decision of the Appeals Panel to the FAO.

D. The Appellant(s) may request a Final Appeal hearing before the FAO by submitting a written request to the Administrator using the email address listed in sub-section 14-2 and include a \$200.00 non-refundable final appeal filing fee by credit card at: compliance@arcaracing.com. The deadline for filing the fee is the same as the deadline for filing the final appeal in all cases.

E. At the Appellant's option, the written request may also include a request for any existing temporary deferral of the Penalty that was issued prior under Section 14 to be continued until such time as the Final Appeals hearing is convened under Section 15 and an FAO decision rendered.

F. The Appellant(s) must send the Final Appeal request to the Administrator within three (3) business days of the issuance of the decision of the Appeals Panel.

15-4 Scheduling of Hearing Date, Deferral of Penalty and Cost Bond; Postponement of Hearing; Withdrawing an Appeal

A. Upon receipt of a valid submission for a Final Appeal to the FAO, the Administrator shall set a hearing date at an appropriate time and place as determined by his or her discretion.

B. In scheduling a final hearing, the Administrator will contact the FAO and both parties in advance of scheduling to determine the earliest practical date, time, and location for the hearing, but the decision of where and when to conduct the hearing is solely at the discretion of the Administrator.

15-5 Publication of Decision

A. ARCA shall have the right to publish any decision of the FAO, including without limitation, the names of the parties involved.

B. An ARCA Member or other witness involved in an Appeal hearing before the FAO shall have no claim or cause of action of any kind against ARCA, its Members, employees, affiliates, the FAO, Appeals Panel Members or any publisher of any information relating to the final decision, including but not limited to claims of defamation, slander and/or libel, since any such claim or claims shall be deemed to have been waived by the appeal.

SECTION 16 - PRIZE MONEY

16-1 Establishment and Distribution of Prize Money

A. All Events shall be contested for a guaranteed finishing position purse as set forth in the Official Entry Blank for each Event.

B. ARCA Members agree to abide by decisions of ARCA in establishing the amount of prize money for each Event.

C. Prize money in all Events that is won by a driver and/or any eligible Competitor of the Car Owner's team shall be paid by ARCA to that Car Owner.

D. All prize money, contingency awards and point funds paid by ARCA will be direct deposited to registered licensed Car Owner and income reported on Car Owner's social security number or Federal ID number as provided to ARCA on W9 form. No prize money will be distributed until current W9 is on file.

E. The Car Owner, not ARCA, shall be solely responsible for the distribution of any and all prize money won by a driver and/or other eligible Competitor(s) of the Car Owner's team, and the sole recourse of such driver or other Competitor(s) for any failure to properly distribute prize money shall be against the Car Owner.

SECTION 17 - POINTS AND POINT FUNDS

17-1 2024 Championship Point Season

Unless otherwise authorized by ARCA, the 2024 Championship point season for

the ARCA Menards Series and ARCA Menards Series East/West will officially close upon the completion of the last scheduled Event for which the Series is a part.

17-2 Administration of Points and Point Funds

- A. ARCA reserves the right to establish, maintain, compile, publish and otherwise operate and award points, Point Funds and trophies.
- B. Owner/Car number combination (as established) must compete in minimum of 50% of races in the respective Series to be eligible for point fund awards.
- C. All Members agree to abide by decisions of ARCA Headquarters in the establishment and administration of the Point Funds.

17-3 Payment of Point Fund Awards

- A. ARCA may require attendance / participation in year-end awards activities for point fund eligibility.
- B. Point fund monies not paid due to ineligibility to be redistributed among eligible participants.

17-4 Distribution of Point Funds

- A. Point Fund money that is won by a Competitor shall be paid by ARCA to the Competitor's Car Owner.
- B. The Car Owner, and not ARCA, shall be solely responsible for the distribution of any and all prize money to the Competitor, and the sole recourse of such Competitor shall be against the Car Owner.
- C. Final point fund distribution will be based on the final Championship point standings at the conclusion of the season and will be distributed on or before December 31, 2024, as described in the 2024 Driver and Car Owner agreement.
- D. ARCA will distribute the Competitor's Point Fund, in accordance with the procedure set forth above to each eligible Competitor according to the following percentage schedule:

<u>Place</u>	<u>% of Total</u>	<u>Place</u>	<u>% of Total</u>
1	20.0	11	2.9
2	10.0	12	2.8
3	9.0	13	2.7
4	8.0	14	2.6
5	7.0	15	2.5
6	6.0	16	2.4
7	5.0	17	2.3
8	4.0	18	2.2
9	3.5	19	2.1
10	3.0	20	2.0

- E. Eligibility to participate in the Point Fund may be forfeited by any Member violating ARCA Rules prior to the presentation of the 2024 awards.

17-5 Award of Points

Championship points for each Point Fund will be awarded as follows:
Drivers and Car Owners

- A. Points will be awarded to each eligible driver and to each vehicle of a Car Owner in each Event according to the finishing position of such driver and vehicle in the Event, as follows:

<u>Finishing Position</u>	<u>Championship Points</u>	<u>Finishing Position</u>	<u>Championship Points</u>
1	43	23	21
2	42	24	20
3	41	25	19
4	40	26	18
5	39	27	17
6	38	28	16
7	37	29	15
8	36	30	14
9	35	31	13
10	34	32	12
11	33	33	11
12	32	34	10
13	31	35	9
14	30	36	8
15	29	37	7
16	28	38	6
17	27	39	5
18	26	40	4
19	25	41	3
20	24	42	2
21	23	43	1
22	22		

B. In addition to the foregoing, one (1) point will be awarded for positions after 43rd place.

C. **Bonus Points:**

- a. Three (3) additional bonus points will be awarded to each driver and Car Owner that win the Race;
- b. One (1) additional bonus point will be awarded to each driver and Car Owner whose vehicle officially leads a lap;
- c. One (1) additional bonus point will be awarded to the driver and Car Owner leading the most official laps.

In the event of ties, duplicate points will be awarded. ARCA Officials will determine the official leader(s) of the Race. The official lap leader and finishing positions will be determined at the start/finish line.

- d. Fifty (50) bonus points will be awarded to each driver and/or Car Owner per established eligibility requirements who compete in 5-race segments (#1-5 as run; Event #6-10 as run, etc.). In the event of postponement and rescheduling of a race, the Event may be moved to an alternative race segment at the discretion of ARCA (all registered drivers and Car Owners to be notified by bulletin). Final leg need not be full 5 races to award bonus points.

e. One (1) additional bonus point will be awarded to the driver and Car Owner for Fastest Qualifier at an Event.

D. If a vehicle makes a Qualifying attempt but fails to earn one (1) of the available starting positions, the Car Owner and driver will be awarded three (3) points and the Car Owner will be credited with a Qualifying attempt. What constitutes a Qualifying attempt will be at the discretion of the Series Director.

E. A driver will be credited only with points as described in section 9-4 Driver Changes.

17-6 Ties

17-6.1 Championship Points

In the event two (2) or more drivers or Car Owners have the same number of points (a tie), the tie breaker in points shall be determined for Drivers and Car Owners based on current season Events in the respective Series in the following order:

- a. Events entered and competed in.
- b. Most victories.
- c. Most top five finishes.
- d. Most top ten finishes.
- e. Most poles.
- f. Average finishing position.
- g. Most laps completed.

The above tie breaker procedure if needed, will also be used for all Special Award programs.

SECTION 18 – ARCA SUBSTANCE ABUSE POLICY

Preamble

Since its inception, ARCA has endeavored to make stock car racing in the United States safe for competitors as well as spectators. In the interest of maintaining the safety of stock car racing, ARCA takes seriously the prevalence of drugs in America's society and, more particularly, their threat to the safety of motorsports. The use of illegal drugs at any time, or the use of alcohol during an ARCA Event, and even the proper use of certain medications during an ARCA Event, may endanger competitors, officials and fans, and such conduct cannot be permitted by ARCA.

The success of ARCA racing has been based upon cooperation between ARCA officials and competitors. The success of ARCA's Substance Abuse Policy (hereinafter "Policy") will be equally dependent upon such cooperation, and ARCA encourages all ARCA members to support this Policy and to cooperate with ARCA in its implementation and application. Although this Policy is intended to apply principally to drivers, mechanics and crew members (hereinafter "Competitor" or "Competitors"), as well as ARCA officials (hereinafter "Official" or "Officials"), it may also be applied to other participants in an ARCA Event.

1. Prohibited Acts and Substances

A. Prohibited Substances

For the purpose of this Policy, prohibited substances are those substances that, in ARCA's determination, may affect adversely the safety and well-being of the Competitors, Officials and/or spectators of the performance of a Competitor or Official in or at an ARCA Event, including but not limited to illegal drugs. ARCA may make this determination with respect to a particular substance at any time, including and without limitation at the time of discovery of the substance following a drug test. Competitors and Officials are prohibited from using, possessing, purchasing,

selling and/or participating in the distribution of illegal substances, regardless of the amount, at any time. Illegal acquisition and/or illegal distribution of any prescription or over-the-counter medication are strictly prohibited at any time.

B. Proper and Improper Use of Prescription and Over-the-Counter Medications

ARCA recognizes that there are many prescription and over-the-counter medications that serve essential or beneficial purposes for the health and well-being of Competitors and Officials, and nothing in this Policy is intended to discourage the proper use of these medications. Just as importantly, however, it must be recognized that there are some medications that, even when properly used, may adversely affect safety in high speed racing events. For example, many types of cough medicines contain codeine, which is a potent narcotic that may result in drowsiness or diminished alertness.

Misuse of a prescription or over-the-counter medication by a Competitor or Official is forbidden and, for those purposes, is deemed to be the use of such a medication in a manner which is inconsistent with the instructions provided by the manufacturer, pharmacist and/or prescribing physician.

To the extent that the use of any substance, including properly prescribed prescription drugs and properly used over-the-counter medications, causes a Competitor or Official to have a competitive advantage, or a diminished or impaired ability to perform his or her duties on the day of an Event, those substances shall be deemed to be prohibited substances for the purposes of this Policy.

C. Alcohol

On the day of an ARCA Event, a Competitor or Official who is participating in the Event is prohibited from consuming any alcohol prior to or during an Event or being under the influence of alcohol. A Competitor or Official is deemed to be under the influence of alcohol if a test performed at, during or immediately after the time of his/her participation in the Event reveals a breath, urine, saliva, or blood alcohol level above 20mg per 100ml (.02%) at the time of testing. Nothing in this paragraph shall preclude an ARCA Official from determining that a Competitor or an Official with a breath, urine, saliva, or blood alcohol test level below 20mg per 100ml (.02%) is physically unfit for race driving, participating, or officiating in an ARCA Event and taking such action as the ARCA Official may deem appropriate under the ARCA Rules.

2. Testing for Drug/Alcohol Use

ARCA may require Competitors and/or Officials to submit to a mandatory test prior to the racing season to determine if the Competitor and/or Official has violated any part of this Policy or has a competitive advantage or diminished ability to perform as a result of using any prohibited substance according to this Policy. ARCA may also require Competitors and/or Officials to submit to random tests throughout the year to determine same. Such tests may include, without limitation, urine, blood, saliva, hair, and/or breath tests. ARCA may also require Competitors and/or Officials to submit to an additional test or tests if an ARCA Official has reasonable suspicion that the Competitor and/or Official has violated any part of this Policy or has a competitive advantage or diminished ability to perform as a result of using any prohibited substance. Some of the conditions, observations and/or reports that may cause an ARCA Official to have such a reasonable suspicion are as follows:

A. When a Competitor or Official is found or observed in possession of illegal drugs or illegal drug paraphernalia at any time.

B. Observation of signs, symptoms and/or behaviors known to accompany the use of prohibited substances or excessive alcohol use or intoxication including, but not limited to:

1. Physical signs of red or droopy eyes, dilated or constricted pupils;
2. Slurred speech, stumbling, or hyperactivity;
3. Needle marks;
4. Repeated and unexplained disappearances from an Event;
5. Nose constantly runs, appears red, or persistent sniffing;
6. Time distortion, including repeated tardiness and missed appointments;
7. Chronic forgetfulness or broken promises;
8. Accidents during Events;
9. Inability to concentrate, remember, or maintain attention;
10. Mental confusion, paranoia, or presence of abnormal thoughts or ideas;
11. Violent tendencies, loss of temper, or irritability;
12. Extreme personality change or mood swings;
13. Deteriorating personal hygiene or appearance.

C. An arrest and/or conviction for driving while under the influence of alcohol or drugs, or a drug related conviction.

D. Receipt of a report from a reliable source that a Competitor or Official is under the influence of alcohol on the day of an ARCA Event, or, at any time, is using, possessing or selling illegal drugs or substance.

E. An examination or test, as provided by the ARCA Rules, which shows evidence of use of a prohibited substance or alcohol abuse or of adulteration or manipulation of the specimen.

F. Aroma of an alcoholic beverage on or about the breath or body of a Competitor or Official consistent with use of an alcoholic beverage on the day of an ARCA Event.

In addition, ARCA may require a Competitor or Official to submit to a test or tests, including without limitation urine, blood, saliva, hair, and/or breath tests, following an incident in which ARCA safety precautions were violated or careless acts were observed during an ARCA Event.

3. Authorization for Testing and Release

If, upon request by ARCA, a Competitor or Official refuses to execute the authorization for testing and release form enclosed with this Policy and deliver it to ARCA by the time designated by ARCA for receipt, that Competitor or Official will not be issued an ARCA Competitor's or Official's license and, if already issued, the ARCA license will be suspended until the Competitor or Official executes the above mentioned authorization and release and delivers it to ARCA. If an ARCA Official directs a Competitor or Official to submit to a urine, blood, saliva, hair and/or breath test as provided by this Policy, that Competitor or Official must consent to and participate in the test by the time designated by the ARCA Official. If that Competitor or Official refuses to consent to and participate in such a test or tests within the time period designated by the ARCA Official, the ARCA Official may eject the Competitor or Official from the racing premises or take such other emergency action as may be appropriate, and that Competitor or Official will also be subject to disciplinary action pursuant to ARCA Rules.

4. Collection and Transport of Specimen(s)

ARCA may designate any independent, third-party agency ("Agency") to administer the collection, transport, and testing of specimens pursuant to this Policy. The Agency may, among other things, be responsible for the following procedures:

A. Ensure that the specimen(s) are from the Competitor or Official in question (including, where necessary, observation of the collection of the specimen(s)).

B. Ensure that the specimen(s) are collected within the time period designated. Normally, collection shall be made within one hour or less of the notification of the Competitor or Official that testing will be conducted, unless a different time is designated by the Agency and/or an ARCA Official based on the circumstances.

C. Ensure that the specimen(s) have not been manipulated by promptly measuring the temperature of the specimen(s). Where results indicated that the sample is inappropriate for testing, the Agency and/or an ARCA Official may require the competitor or Official to provide additional specimen(s) as necessary.

D. Label, secure, and transport the specimen(s) to ARCA's designated testing facility, which may or may not be affiliated with the Agency, in such a manner as to ensure that the specimen(s) are not misplaced, tampered with, or relabeled.

E. Provide a form to be completed by the Competitor or Official in question that identifies all prescription and over-the-counter medications consumed by the Competitor or Official in the preceding three months.

All specimens collected under this Policy are the property of ARCA.

5. Facility for Testing

All testing will be done at a facility or facilities exclusively selected by ARCA from among those facilities that have been certified by the Substance Abuse and Mental Health Services Administration of the United States Department of Health and Human Services and/or by the College of American Pathologists Forensic Urine and Drug Testing Program.

6. The ARCA designated testing facility will determine whether and in what amount a particular specimen tests positive with respect to a prohibited substance and/or alcohol, and whether the specimen has been adulterated or manipulated. The testing facility will transmit the results to ARCA's Policy Administrator, and to ARCA's designated Medical Review Officer for interpretation, and the Medical Review Officer shall promptly notify ARCA's Policy Administrator or his designee whether or not, upon the Medical Review Officer's independent review, the specimen(s) yielded a "true positive" result and/or were adulterated or manipulated. A specimen may be retested at any time at the direction of ARCA.

7. Procedures if a Test Shows the Presence of Prohibited Substances or Alcohol

A. With respect to prohibited substances other than alcohol:

1. Upon being notified by ARCA's designated Medical Review Officer that a Competitor or Official has tested "true positive" for a prohibited substance (including any re-test of the original sample, if so requested by the Competitor or Official), ARCA's Policy Administrator or his designee will suspend that Competitor's or Official's ARCA license for an indefinite period and/or take such other disciplinary action deemed appropriate under the circumstances pursuant to the ARCA Rules.
2. If that Competitor or Official wishes to return to racing or officiating

during or after the suspension period, that Competitor or Official must submit to a re-test or re-tests. This will be done at a time and place and under conditions specified by ARCA, at the Competitor's or Official's expense, which expense will include laboratory fees and all other direct and indirect costs incurred by ARCA in connection with each test. If and when a Competitor's or Official's test shows no evidence of a prohibited substance, that Competitor or Official may return to racing or officiating, but only if he or she is not otherwise ineligible and agrees to future random tests for any substance, drug or alcohol at such times and places as may be determined by ARCA, at the expense of the Competitor or Official. Such future tests by ARCA need not be based upon reasonable suspicion or fall under the random testing criteria.

B. With Respect to Alcohol:

1. Upon being notified by ARCA's designated Medical Review Officer that a Competitor or Official has been determined to have consumed alcohol in violation of this Policy (including any re-test of the original sample, if possible, and requested by the Competitor or Official), the ARCA Policy Administrator or his designee may suspend that Competitor's or Official's ARCA license for an indefinite period and/or take such other disciplinary action deemed appropriate under the circumstances pursuant to the ARCA Rules.
2. If a Competitor or Official wishes to return to racing or officiating during or after the suspension period, he or she must agree to future random tests for any substance, drug or alcohol at such times and places as may be determined by ARCA, at the expense of the Competitor or Official. Such future tests by ARCA need not be based upon reasonable suspicion or fall under the random testing criteria.

C. ARCA may publish the results of any test or tests conducted pursuant to this Policy and the circumstances giving rise to such test to such third parties as ARCA, in its sole discretion, deems reasonable under the circumstances. The Competitor or Official shall have no claim or cause of action of any kind against ARCA or any director, officer, employee or agent of ARCA with respect to such publication.

D. The actions and requirements of this Paragraph 7 apply for self-reported violations of this Policy for prohibited substances other than alcohol (Paragraph 7.A.) and for alcohol (Paragraph 7.B.), whether or not a specimen is collected under this Policy.

8. Falsification or Withholding Information

Any Competitor or Official who attempts to or does falsify, alter, or otherwise tamper with any specimen or any aspect of a test performed under this Policy will be subject to disciplinary action pursuant to the ARCA Rules. A specimen that is identified as having been adulterated or manipulated shall be treated in the same manner as a "true positive" test result for a prohibited substance other than alcohol, with all of the consequences of such a positive test, including those provided in Paragraph 7.A.1 and 2, above.

9. Disciplinary Action for Prohibited Acts Where There is No Evidence of or Testing for Prohibited Substances or Alcohol.

With respect to any prohibited act described herein, if an ARCA Official determines that a Competitor or Official has engaged in any such prohibited act, the ARCA Official may eject the Competitor or Official from the racing premises or take such other emergency action as is appropriate, and that Competitor or Official will also be subject to disciplinary action pursuant to the ARCA Rules.

10. Treatment for Drugs/Alcohol

If requested, ARCA will provide a list of credible drug or alcohol rehabilitation programs. ARCA strongly encourages self-help and treatment for those afflicted with a drug problem or alcohol abuse. Many worthy programs, both public and private, are available for the treatment of drug and alcohol abuse. ARCA will continue its efforts to support a drug free America and a society in which alcohol is not abused.

11. Applicability of the ARCA Rules

This Policy, as it may be amended from time to time, is a supplement to the provisions of the ARCA Rules, and will be interpreted and applied by ARCA Officials. This Policy is binding upon all ARCA members in the same manner and to the same extent as are the provisions of the ARCA Rules.

SECTION 20C ARCA MENARDS SERIES SPECIFICATIONS

Open to ARCA-approved automobile manufacturers provided they comply with, and adhere to, specifications as outlined for this Series.

NOTICE

ALL MODEL, ENGINE OR EQUIPMENT CHANGES OR MODIFICATIONS NOT SPECIFICALLY ADDRESSED IN THIS RULE BOOK BY ARCA MUST BE SUBMITTED, IN A COMPLETED FORM/ASSEMBLY, TO ARCA FOR CONSIDERATION OF APPROVAL, ON OR PRIOR TO SEPTEMBER 3, 2024, UNLESS OTHERWISE AUTHORIZED BY ARCA, TO BE CONSIDERED FOR COMPETITION FOR THE 2025 SEASON. THE APPLICANT WILL BE NOTIFIED OF APPROVAL OR REJECTION FROM ARCA. RACE EQUIPMENT WILL NOT BE CONSIDERED AS HAVING BEEN APPROVED BY REASON OF HAVING PASSED THROUGH INSPECTION AT ANY TIME OR ANY NUMBER OF TIMES UNOBSERVED OR UNDETECTED. ANY RACE EQUIPMENT WHICH DOES NOT CONFORM TO SPECIFICATIONS OR TOLERANCES CONTAINED IN THE 2024 ARCA RULE BOOK, OR IS NOT OTHERWISE APPROVED BY ARCA, MAY NOT BE USED IN ARCA COMPETITION IN 2024. ALL SUBMITTED RACE EQUIPMENT MUST BE ACCOMPANIED BY COMPUTER-AIDED DESIGN (CAD) FILES AND/OR MECHANICAL DRAWINGS AND REQUISITE FEE AS DETERMINED BY ARCA.

20C - 1 COMPETING MODELS AS SELECTED BY ARCA

20C - 1.1 ARCA Menards Series Races

ARCA Menards Series Races are open only to approved models of the Grand National-Approved (Flange Fit) Composite Body.

20C - 1.2 ARCA Menards Series

The ARCA Menards Series will compete with the rules as specified in Section 20C of the Rule Book. If authorized by ARCA, deviations to these rules may be permitted for stand-alone Events only. All combination Events will be governed by the rules as published in Section 20C of the Rule Book.

The NASCAR-approved (Generation 5) frame and roll cage assembly consisting of main frame rails, upper left side frame rail, trailing arm crossmember assembly, rear sub-frame assembly and numbered roll bars (#1 through #19) will be permitted. The frame and roll cage assembly must be NASCAR-approved and meet the specifications and dimensions as described in sub-sections 20C-11.2 (Frame Requirements), 20C-18 (Roll Bars) and shown in Diagrams #1A through #4B in the rear pages of the Rule Book.

When the NASCAR-approved (Generation 5) frame and roll cage assembly is used it must meet the following specifications. Unless otherwise specified within this Rule Book all other components and specifications such as suspension, tread width, body location and wheelbase must meet the specifications in the 2024 ARCA Menards Series Rule Book.

20C - 1.3 APPROVED COMPETITION MANUFACTURERS AND MODELS

A. 2024 Racing Season:

The following are the only approved models for competition in the ARCA Menards Series in 2024:

2014 Grand National-Approved (Flange Fit) Composite Body

Approved Models:

Chevrolet – SS

Ford – Fusion

Toyota – Camry

2022 Grand National-Approved (Flange Fit) Composite Body

Approved Models:

Ford – Mustang

B. 2025 Racing Season:

Any new vehicle model to be considered for approval for competition in the 2025 season must be submitted by the manufacturer to ARCA for initial consideration not later than June 7, 2024, unless otherwise authorized by ARCA. At the manufacturer's expense, the manufacturer must provide all information, materials, electronic files, benchmark production vehicle(s) and race-version vehicle(s) as requested by ARCA

on or before any dates specified by ARCA. The manufacturer must cooperate with ARCA to enable ARCA and the NASCAR Research and Development Center to complete all necessary track tests, aerodynamic tests, and other competitive analysis by September 3, 2024, unless otherwise authorized by ARCA. All new vehicle models submitted to ARCA for approval by the manufacturer must conform to the same body configuration and meet the spirit and intent of competitive racing as currently evidenced in this Series. All new vehicle models submitted to ARCA for approval must complete the ARCA Series OEM Body Approval Process. To begin the ARCA Series OEM Approval Process, an OEM must complete and submit the ARCA Series OEM Body Approval Initiation Request Form to the ARCA President.

20C - 2 GENERAL VEHICLE BODY REQUIREMENTS

20C - 2.1 Vehicle Bodies

The vehicle body must be acceptable to ARCA Officials and meet the following minimum requirements:

A. The eligible bodies will be volume production models as selected and approved by ARCA (See sub-section 20C-1.3).

B. The Grand National-Approved (Flange Fit) Composite Bodies are the only bodies approved for competition. The Bodies must remain as manufactured and must meet all other specifications as set forth in Section 20C of the ARCA Rule Book. Alterations, that in the judgment of ARCA Officials were made to enhance performance, will not be permitted. The manufacturer's label must remain visible and unaltered. The Grand National-Approved (Flange Fit) Composite Bodies must be mounted in accordance to the mounting instructions in the Construction Guidelines (Diagrams #6A, B, C & D) at the rear of the Rule Book. All installations must be acceptable to ARCA Officials.

C. Vehicles must be neat appearing. The interior and exterior of all floors, firewalls, roll cage and frame assemblies must be painted using only light / bright colors. The type of paint used, whether it be flat, satin, or high gloss finish, must provide a smooth surface. The paint or vinyl used on the exterior of the body panels must not be textured and must provide a smooth surface. Vinyl may only be used on the exterior of the body panels. Thermal barrier coatings applied to the immediate driver's area may be used. The location of thermal coatings must be acceptable to ARCA Officials.

Painting the interior of the body panels will be permitted using only light gray or clear coat paint. The paint must not be textured and must provide a smooth surface. The manufacturer body panel identification labels must remain unaltered. All body seams must remain identifiable and visible at all times. Covering or filling in of the body seams will not be permitted. Tape will not be permitted on hood and rear decklid seams.

D. The exterior dimensions of all bodies must remain as approved by ARCA. The body must not be offset on the frame.

E. The body must be located so that when measured horizontally from the center of the roof at the pivot to the vertical centerline of the rear axle housing must be 49 inches plus or minus (+/-) 1/2 inch for all 110 inch wheelbase vehicles and 45 inches plus or minus (+/-) 1/2 inch for all 105 inch wheelbase vehicles.

F. All vehicles must have complete bodies, hoods, fenders, bumper covers, etc. and must be acceptable to ARCA Officials.

G. Vehicles must be equipped with complete front and rear bumper covers for the make and model and must be approved by ARCA.

H. Streamlining of the contours of the vehicle, beyond that approved by the Series Director, will not be permitted. Installation of air directional devices, underpans, baffles, shields or the like beneath the vehicle or the vehicle's hood and fender area, front firewall, floor, rear firewall area, rear deck and quarter panel area will not be permitted. If, in the judgment of ARCA Officials, any part or component of the vehicle, not previously approved by ARCA, that has been installed or modified to enhance aerodynamic performance, will not be permitted. All vehicles must remain standard in appearance.

I. All seams of the interior sheet metal and all interior sheet metal to exterior body panel contact points must be sealed and caulked. This includes, but is not limited to, floors, firewalls, wheel wells, package trays, crush panels and any removable covers.

20C - 2.2 Overall Vehicle Weight

A. At all times, prior to the Race, all vehicles must meet the applicable minimum vehicle weight and must maintain a minimum right side weight (as listed below) ready to compete, with fluids (fuel, oil, engine coolant, etc.).

B. At all road course Events, all vehicles must maintain a minimum left side and right side weight (as listed below) ready to compete, with fluids (fuel, oil, engine coolant, etc.).

C. The driver's weight will not be included in the minimum vehicle weight.

D. The driver's weight will be measured by ARCA Officials, at a date(s) and time(s) determined by ARCA, in its sole discretion.

E. In the event of a driver change, the minimum vehicle weight will be determined by the weight of the driver that qualified the vehicle for the Event.

F. Minimum Vehicle Weights:

Vehicles competing with the ARCA Ilmor and Legacy engines:

Driver Weight Bracket (lbs.)	Minimum Vehicle Weight w/o Driver	Minimum Right Side (Ovals)	Minimum Left Side/Right Side (Road Course)
250 lbs. & Above	3175 lbs.	1584 lbs. 1559 lbs. (Gen. 5)	1617 lbs. 1592 lbs. (Gen. 5)
225 – 249 lbs.	3200 lbs.	1584 lbs. 1559 lbs. (Gen. 5)	1617 lbs. 1592 lbs. (Gen. 5)
200-224 lbs.	3225 lbs.	1584 lbs. 1559 lbs. (Gen. 5)	1617 lbs. 1592 lbs. (Gen. 5)
175 – 199 lbs.	3250 lbs.	1584 lbs. 1559 lbs. (Gen. 5)	1617 lbs. 1592 lbs. (Gen. 5)
150 – 174 lbs.	3275 lbs.	1584 lbs. 1559 lbs. (Gen. 5)	1617 lbs. 1592 lbs. (Gen. 5)
125 – 149 lbs.	3300 lbs.	1584 lbs. 1559 lbs. (Gen. 5)	1617 lbs. 1592 lbs. (Gen. 5)

Vehicles competing with the approved “Spec” and Built engines with hood/roof flaps:

Driver Weight Bracket (lbs.)	Minimum Vehicle Weight w/o Driver	Minimum Right Side (Ovals)	Minimum Left Side/Right Side (Road Course)
250 lbs. & Above	3200 lbs.	1596 lbs. 1571 lbs. (Gen. 5)	1629 lbs. 1604 lbs. (Gen. 5)
225 – 249 lbs.	3225 lbs.	1596 lbs. 1571 lbs. (Gen. 5)	1629 lbs. 1604 lbs. (Gen. 5)
200-224 lbs.	3250 lbs.	1596 lbs. 1571 lbs. (Gen. 5)	1629 lbs. 1604 lbs. (Gen. 5)
175 – 199 lbs.	3275 lbs.	1596 lbs. 1571 lbs. (Gen. 5)	1629 lbs. 1604 lbs. (Gen. 5)
150 – 174 lbs.	3300 lbs.	1596 lbs. 1571 lbs. (Gen. 5)	1629 lbs. 1604 lbs. (Gen. 5)
125 – 149 lbs.	3325 lbs.	1596 lbs. 1571 lbs. (Gen. 5)	1629 lbs. 1604 lbs. (Gen. 5)

Vehicles competing with the approved “Spec” and Built engines without hood/roof flaps:

Driver Weight Bracket (lbs.)	Minimum Vehicle Weight w/o Driver	Minimum Right Side (Ovals)	Minimum Left Side/Right Side (Road Course)
250 lbs. & Above	3225 lbs.	1608 lbs. 1583 lbs. (Gen. 5)	1642 lbs. 1617 lbs. (Gen. 5)
225 – 249 lbs.	3250 lbs.	1608 lbs. 1583 lbs. (Gen. 5)	1642 lbs. 1617 lbs. (Gen. 5)
200- 224 lbs.	3275 lbs.	1608 lbs. 1583 lbs. (Gen. 5)	1642 lbs. 1617 lbs. (Gen. 5)
175 – 199 lbs.	3300 lbs.	1608 lbs. 1583 lbs. (Gen. 5)	1642 lbs. 1617 lbs. (Gen. 5)
150 – 174 lbs.	3325 lbs.	1608 lbs. 1583 lbs. (Gen. 5)	1642 lbs. 1617 lbs. (Gen. 5)
125 – 149 lbs.	3350 lbs.	1608 lbs. 1583 lbs. (Gen. 5)	1642 lbs. 1617 lbs. (Gen. 5)

G. Unless otherwise authorized by the Series Director, at all times all weights will be measured by ARCA Officials using the scales provided by ARCA. It is the responsibility of each race team to ensure that its vehicle meets the specified minimum weight requirements for this Series on these scales.

H. On major components, the use of non-magnetic and/or hollow fasteners and component mounting hardware with the intent of weight reduction will not be permitted.

I. Unless otherwise approved, Race Equipment, including vehicle parts and components, that in the judgment of ARCA Officials have been constructed to increase the components weight beyond normal standards will not be permitted.

J. Before the use of any composite component(s), the component(s) must be submitted to and approved by ARCA for use in competition.

20C - 2.3 Added Vehicle Weight

A. Added weight must be in block form of not less than five (5) pound blocks (no pellets) and painted white with the vehicle number permanently legible on it.

B. Any weight added to the vehicle must be bolted inside the body shell in an approved weight container and in a position acceptable to ARCA Officials. All weight containers must be welded directly to the main frame rails, crossmembers attached to the main frame rails, rear sub-frame rails and the rear sub-frame rear crossmember. Weight containers welded to the main frame rails or crossmembers attached to the main frame rails will not be permitted to extend below the bottom surface of the main frame rails or crossmembers attached to the main frame rails. When the NASCAR-approved (Generation 5) frame and roll cage assembly is used all weight containers welded to the main frame rails must meet the minimum ground clearance requirements as described in sub-section 20C-12.8.2. Added weight must not be mounted beyond the front and rear sub-frame assembly. Added weight must be secured in a manner acceptable to ARCA Officials that will prevent movement of the added weight while in competition. The weight container must be reinforced at each end to support the weight retention through-bolt. At all times, each end of the weight container must have a weight retention through-bolt of not less than 7/16 inch diameter (installed from the top or side of the weight container) and be sealed with a metal cap or covered with a magnetic steel cap and welded. The front of the weight container must be plated and welded completely closed using the same thickness of material as the weight container. A single, round, maximum one (1) inch diameter hole will be permitted in the center of the plate to access added weight. Added weight containers will not be permitted forward of the engine firewall. Material must be acceptable to ARCA Officials.

C. One (1) front sway bar mounting tube ballast container will be permitted. Additional added weight containers will not be permitted forward of the engine firewall. If used it must meet the following requirements:

1. The ballast container must be mounted in front of the front sway bar mounting tube. The ballast container must be mounted flush with and welded to the sway bar mounting tube and front sub frame rails. Four (4), two (2) inches long by one (1) inch wide by 0.090 inch thick support straps must be welded connecting the weight container to the sway bar tube. Two (2) of the support straps must be evenly spaced along the top and two (2) along the bottom of the weight container.
2. The ballast container must be constructed of two (2) inch by three (3) inch magnetic steel box tubing with a minimum wall thickness of 0.075 inch, meeting the ASTM A-500 specification.
3. The ballast container length must not exceed the length of the front sway bar mounting tube. Centerlines of the sway bar mounting tube and sway bar mounting tube ballast container must remain parallel.
4. The right hand side of the ballast container must be welded and closed completely using the same material as the container. A maximum one (1) inch hole in the center will be permitted. The left hand side must have a weight retention through-bolt of not less than 7/16 inch diameter (installed from the top or side of the weight container) and be sealed with a metal cap.
5. Added ballast must be secured in a manner that will prevent movement of the ballast while in competition.

D. When the approved "Spec Engine" is used a front sway bar mounting tube ballast container must be installed and have a minimum of 50 lbs. of ballast installed at all times during competition.

20C - 2.4 Vehicle Weights After Competition

A. After a vehicle has qualified, only fluids consumed, as determined by ARCA Officials, may be replaced.

B. At the end of the Race, the minimum weight of the vehicle must be within one half of one percent (.5%) of the minimum weight requirement of the vehicle at the start of the Race. When vehicles are weighed after a Race, only fuel in the fuel cell may be added. Wheels and tires may not be changed, unless otherwise authorized by ARCA Officials.

C. The addition of ballast weight, after competition, will not be permitted.

20C - 3 DETAILED VEHICLE BODY REQUIREMENTS

In addition to the General Vehicle Body Requirements specified in sub-section 20C-2, the following Detailed Vehicle Body Requirements must be maintained.

20C - 3.1 Front Air Dam

A. Approved front air dams must have a minimum ground clearance of four (4) inches for all models. When an air dam extension is attached to the front bumper

cover it must be a flush-mounted, stationary, securely fastened, single layer not exceeding a maximum thickness of 3/16 inch and must be mounted parallel to the bumper cover. The air dam extension must be secured in a manner that will prevent movement of the air dam extension while in competition. All support brackets must be mounted to the rear of the air dam.

B. The outer edge of the lower air dam and front fenders must not extend beyond the limits of the ARCA measuring device(s).

C. A horizontal protective panel mounted to the front air dam flange will be permitted. The panel, if used, must be mounted on the lower side of the front air dam flange. The panel, if used, must not extend beyond the trailing edge of the front air dam flange. The panel, if used, must be constructed from either aluminum or plastic (the use of steel or exotic materials will not be permitted) and must not be more than a maximum thickness of 1/2 inch. The mounting and material used must be acceptable to ARCA Officials.

20C -3.1.1 Rear Spoilers

A. An ARCA-approved rear spoiler must be installed at all times during competition. The rear spoiler must be a flat metal non-adjustable part of the body that controls the flow of air over one (1) surface only. The rear spoiler must be from an approved manufacturer. The rear spoiler must be used exactly as manufactured and supplied by the approved rear spoiler manufacturer without any modifications. The following are the only ARCA-approved rear spoilers:

<u>MANUFACTURER</u>	<u>PART NUMBER</u>
Five Star Race Car Bodies	14001-67033
Richardson Racing Products, Inc.	K&N-61-6.25

B. The manufacturer's part number must remain visible and unaltered at all times.

C. The rear spoiler must be mounted in the approved location using fasteners in all the mounting holes provided in the rear spoiler flange.

D. The rear spoiler must maintain a minimum angle of 70 degrees at all times during the Event.

E. Rear spoiler sizes and/or angles may be adjusted at ARCA's discretion at any time during the Event.

20C - 3.2 WINDOWS / LIGHTS / MIRRORS

20C - 3.2.1 Windshield / Windshield Braces

A. Only ARCA-approved laminated and non-laminated windshields will be permitted. The windshield must remain as supplied from the approved manufacturer. The following is a list of ARCA-approved windshields:

<u>YEAR</u>	<u>MODEL</u>	<u>FIVE STAR RACE CAR BODIES</u>
2014	Chevrolet SS	14121-63443 14121-63443-2 (Laminated)
2014	Ford Fusion	14311-63443 14311-63443-2 (Laminated)
2014	Toyota Camry	14711-63443 14711-63443-2 (Laminated)
2022	Ford Mustang	14311-63443 14311-63443-2 (Laminated)

The manufacturers approved part number must be clearly visible and unaltered in the windshield.

B. The approved laminated windshield must be used at all tracks except for ARCA West Series stand-alone and ARCA West Series combination Events.

C. The windshield must be bolted in using the predrilled mounting holes with 1/4 inch diameter button head allen screws using a 5/32 inch allen wrench. The windshield mounting screws must remain tight and stationary for the entire Event.

D. The windshield mounting bed must be as produced by the approved manufacturer. Holes and/or other modifications that, in the judgment of ARCA Officials, were cut or drilled for any purpose other than as specified above, will not be permitted.

E. Adhesive must be used to seal the windshield to the windshield bed but must allow the windshield to easily be removed. Windshield perimeter must remain flush with the body surface for the entire Event.

F. The interior side of the front windshield must be supported by a minimum of three (3) non-adjustable, rigid, one (1) inch wide reinforced metal braces. The front windshield braces must be evenly spaced using the recessed areas in the windshield mounting bed with a minimum of one (1) brace mounted on the left side and a minimum of one (1) brace mounted on the right side of the center windshield bar (4A). The center windshield brace must be mounted to the center windshield bar

(4A) using a minimum of two (2) positive fasteners. The outer braces must be bolted to the dash panel at the bottom and windshield bed or roof bar (#3 or #3A) using 1/4 inch magnetic steel fasteners. All windshield braces must remain in contact with the inner windshield surface.

G. The windshields must be clear. A maximum of six (6) inches of tint from the top down will be permitted. Additional windshield tint or tape may be added for adverse sunlight conditions. Unless otherwise authorized by ARCA Officials, the addition of tint or tape must be confined to the driver's side of the windshield. Additional tint to the right side of the center windshield bar (#4A) will not be permitted.

H. Windshield tear-offs may be used on the front windshield only. Tear-offs must be installed securely to prevent loss during competition. Windshield tear-offs must be clear. If windshield tear-offs are used, the maximum size of a pull tab when measured from any point is three (3) inches. Pull tabs, if used, may only be installed on one (1) side of the tear-off. All windshield tear-offs and pull tabs must be acceptable to ARCA Officials.

20C - 3.2.2 Rear Window

A. Only ARCA-approved rear windows will be permitted. The rear window must remain as supplied from the approved manufacturer. The following is a list of ARCA-approved rear windows:

<u>YEAR</u>	<u>MODEL</u>	<u>FIVE STAR RACE CAR BODIES</u>
2014	Chevrolet SS	Part # 14121-61353
2014	Ford Fusion	Part # 14311-61353
2014	Toyota Camry	Part # 14711-61353
2022	Ford Mustang	Part # 14311-61353

The manufacturers approved part number must be clearly visible and unaltered in the rear window.

B. The rear window must be bolted in using the predrilled mounting holes with 1/4 inch diameter flat head (flush mounted) allen screws. All screws must be able to be removed using a 5/32 inch allen wrench. The rear window mounting screws must remain tight and stationary for the entire Event.

C. Adhesive sealant must be used to seal the rear window to the rear window mounting bed but must allow the rear window to easily be removed.

D. The rear window mounting bed must be as produced by the approved manufacturer. Holes and/or other modifications that, in the judgment of ARCA Officials, were cut or drilled for any purpose other than as specified above, will not be permitted.

E. Tint will not be permitted. Access holes in the rear window for the rear jacking bolts and track bar adjuster must not exceed a maximum diameter of 1-1/4 inches.

F. The interior side of the rear window must be supported by a minimum of two (2) and a maximum of five (5) non-adjustable, ridged, one (1) inch wide reinforced metal braces. The rear window braces must be evenly spaced using the recessed areas in the rear window mounting bed with a minimum of one (1) brace mounted on the left side and a minimum of one (1) brace mounted on the right side of the longitudinal centerline. Each rear window brace must be mounted flush to the interior side of the rear window from top to bottom using a minimum of three (3) evenly spaced 1/4 inch diameter flat head (flush mounted) allen screws to prevent movement (rear window mounting screws are not included). All screws must be able to be removed using a 5/32 inch allen wrench.

G. Each rear window brace must have a non-adjustable vertical rear window brace support installed. The vertical rear window brace support must be a minimum of 1/4 inch diameter and must be attached to the rear window longitudinal brace and attached near the intersection of the rear firewall and rear package tray. The installed rear window braces and supports must keep the rear window rigid in all directions, at all times and all ARCA templates must fit correctly.

20C - 3.2.3 Side Window / Quarter Window

A. On all oval tracks 1-1/4 miles or less in length side windows will not be permitted. On all oval tracks over 1-1/4 miles in length vehicles will be required to have a full one-piece flat 1/4 inch thick clear polycarbonate window installed in the right side window opening. Right side windows on road courses will not be permitted.

B. The right side window, including its mounting track, must be inset 3/4 inch along the entire length of the roof and the "A" post. The bottom of the right side window must be inset 3/4 inch at the "A" post and follow a straight line ending flush with the "B" post and at the door top. The upper mounting track across to the top of the right side window opening must be a minimum of 27 inches in length with a maximum height of one (1) inch. The lower mounting track must extend from the bottom of the "A" post rearward along the top of the door panel a minimum of 25 inches with a maximum height of one (1) inch. The window must be mounted in a manner acceptable to ARCA Officials and in such a way that the driver or the track

crews can easily remove it. Tape will not be permitted on the side window. One dual outlet NACA duct equipped with a maximum of two (2), three (3) inch hoses may be installed in the right side window as far forward as possible for driver cooling. Fans will not be permitted.

C. Panels, vents (NACA ducts) or hoses in the left side window opening will not be permitted. An optional clear right side vent (NACA duct) will be permitted. The vent (NACA duct) may be a single or dual inlet. The overall size must not be more than ten (10) inches in height and ten (10) inches in length. When installed the vent (NACA duct) must be installed in the window opening where the top of the door panel and the trailing edge of the "A" post intersect. The vent (NACA duct) must not be restricted. The vent (NACA duct) must be configured for air intake only. Suction ducts will not be permitted. Hoses attached to the vent (NACA duct) may be used for cooling only and must exhaust forward of the horizontal shoulder bar (#7). The hoses must be fully functional without any restrictions. Fans will not be permitted in the hoses. The installation of the vent (NACA duct) must be acceptable to ARCA Officials.

D. Only ARCA-approved quarter windows will be permitted. The quarter window must remain as supplied from the approved manufacturer. The following is a list of ARCA-approved quarter windows:

<u>YEAR</u>	<u>MODEL</u>	<u>FIVE STAR RACE CAR BODIES</u>
2014	Chevrolet SS	Part # 14121-65353L Part # 14121-65353R
2014	Ford Fusion	Part # 14311-65353L Part # 14311-65353R
2014	Toyota Camry	Part # 14711-65353L Part # 14711-65353R
2022	Ford Mustang	Part # 14311-65353L Part # 14311-65353R

The manufacturers approved part number must be clearly visible and unaltered in the quarter window.

E. Only flush-mounted quick release fasteners are permitted.

F. A painted border, a maximum of one (1) inch wide, will be permitted around the outside edge only.

G. All air vents (NACA ducts) in the quarter windows must be clear and configured for air intake only. Suction ducts will not be permitted. A maximum of three (3) inlets per quarter window. When installed the maximum angle of an air vent (NACA duct) permitted will be 45 degrees. Open air vents (NACA ducts) (without a hose attached) must be sealed both exterior and interior. The maximum hose size is three (3) inches. All hoses must be fully functional without any restrictions. Hoses connected to an air vent (NACA duct) not used for cooling the driver, must be connected to a fan or cooler and must exhaust outside the interior. A maximum of two (2) open ended hoses for cooling the driver may be used and must exhaust forward of the horizontal shoulder bar (#7). Fans will not be permitted in the hoses cooling the driver. One standard air vent (NACA duct) with a four (4) inch high by seven (7) inch long opening with a three (3) inch outlet must be installed in the left side quarter window as far forward and as low as possible. The air vent (NACA duct) must be mounted horizontal to the door top and must remain open and unrestricted at all times. Additional intake ducts may be added at the discretion of the Series Director.

20C - 3.2.4 Headlights / Parking Lights

A. Approved headlight, parking light, upper grille, manufacturers identification and taillight body graphics (decals) must be installed for brand identity.

B. The body graphics (decals) must be from an approved manufacturer and must be acceptable to ARCA Officials. The body graphics (decals) must remain as supplied and unaltered. The following are the only approved body graphics (decals).

<u>YEAR</u>	<u>MODEL</u>
2014	Chevrolet SS
2014	Ford Fusion
2014	Toyota Camry
2022	Ford Mustang

20C - 3.2.5 Rear View Mirror

A. Multi-view type mirrors, with a maximum width of 26 inches, must be installed at all times during competition.

B. A single, side-mounted rear view mirror may be used. If used, the side-mounted mirror and housing can be a maximum of four (4) inches in diameter, length, width and height and must be mounted to the vertical vent window bar

(#10A). The side-mounted rear view mirror must not extend outside of the vehicle at any time or in any position. The side-mounted rear view mirror and installation must be acceptable to ARCA Officials.

C. Composite material(s) on the rear view mirrors will be permitted and must be acceptable to ARCA Officials.

20C - 3.3 Dash Panel

A. The left side dash panel between the left side front roll bar leg (#2A) and the center windshield bar (#4A) must be constructed of magnetic sheet steel welded in place or be an ARCA-approved composite assembly meeting the SFI 56.1 specification, and securely fastened in place. The dash panel must extend up vertically from the dash panel bar (#8) not less than four (4) inches and break forward to create a horizontal panel parallel to the main frame rails and fill the space between the dash panel bar (#8) and the front firewall. The end of the dash panel at the center of the vehicle must be closed. The lower edge of the dash panel must not be lower than the top of the steering column. The gauge panel must not be less than four (4) inches in height and must be made of metal. A removable magnetic steel or ARCA-approved composite material inspection panel, for easy access beneath the dash panel area must be installed on the top and fastened with wing-type quick release fasteners. All ARCA-approved composite dash components must meet the SFI 56.1 specification and display a valid SFI 56.1 label. All dash panels must be acceptable to ARCA Officials.

B. The right side dash panel must be located between the right side front roll bar leg (#2B) and the center windshield bar (#4A) and top of the dash panel bar (#8) and the front firewall. The right side dash panel must be constructed of solid magnetic sheet steel welded in place or be an ARCA-approved composite assembly meeting the SFI 56.1 specification. The right side dash panel must be flat and parallel to the main frame rails and fill the space between the right side front roll bar leg (#2B), the center windshield bar (#4A), the dash panel bar (#8) and the front firewall. All right side dash panels must be acceptable to ARCA Officials.

C. The rearward edge of the left side dash panel, when measured at the center of the windshield rearward, must not be longer than 22 inches and must not be further forward than the dash panel bar (#8). The rearward edge of the right side dash panel cannot be further rearward than the dash panel bar (#8).

D. Holes and/or other modifications in the left side dash panel, or the right side dash panel that, in the judgment of ARCA Officials, were made with the intent of weight reduction will not be permitted.

20C - 3.4 Firewalls / Floor /Transmission Tunnel / Drive Shaft Tunnel

All firewalls, floors, tunnels, and access panels must be installed and completely secured in place when the vehicle is in competition.

Any device or duct work that allows air to pass from one area of the interior of the vehicle to another, or to the outside of the vehicle, will not be permitted. This includes, but is not limited to, the inside of the vehicle to the trunk area, or the floors, firewalls, crush panels and wheel wells passing air into or out of the vehicle.

All seams of the interior sheet metal and all interior sheet metal to exterior body panel contact points must be sealed and caulked. This includes, but is not limited to, floors, firewalls, wheel wells, package trays, crush panels and any removable covers.

20C – 3.4.1 Front Firewall

A. The engine firewall must be as wide as the outside of the frame rails and must be magnetic sheet steel, a minimum thickness of 0.027 inch, with seams welded and mounted vertically without any offsets. The firewall must remain vertical to within eight (8) inches from the top of the frame rails and must connect to the floor pan within seven (7) inches rearward of the vertical firewall.

B. The use of vertical front firewall extensions is highly recommended. If used the vertical front firewall extensions must meet the following specifications:

- A minimum 0.027 inch thick magnetic sheet steel vertical front firewall extensions must be attached to the vertical front firewall and fill the area between the vertical front firewall, rocker panels and flush with the inside surface of the front fenders rearward of the wheel opening and to the top of the vertical front firewall. Only one (1) radius (concave) will be permitted between the vertical front firewall and the inside vertical surface of the front fenders.

C. The use of vertical front firewall end panels is highly recommended. If used the vertical front firewall end panels must meet the following specifications:

A minimum 0.027 inch thick magnetic sheet steel vertical front firewall end panel must be welded in place to connect and seal the left and right ends of the vertical front firewall and lower angled panels to the left and right front roll bar legs (#2A & B).

D. It is required that one (1) of the vertical front firewall recommendations (extensions or end panels) as described in “B” or “C” above must be used. The use of both is highly recommended.

When the NASCAR-approved (Generation 5) frame and roll cage assembly is used it must meet the following specifications. Modifications to any of the specifications or components will not be permitted.

The front firewall must be constructed using a main vertical section, two (2) angled sections connecting the vertical section to the left and right floor pans, a transmission tunnel opening, and a windshield filler panel.

A. The front firewall vertical section must be located two (2) inches forward of the forward ends of the main frame rails. The front firewall vertical section must be as wide as the outside width of the main frame rails (58 inches) and must be magnetic sheet steel, a minimum thickness of 0.027 inch, with seams welded and mounted perpendicular to the inspection surface without any offsets. The front firewall vertical section must start at a point eight (8) inches above the top of the main frame rails and end at a point above the front sub-frame bars (#16A & B) where they intersect the front firewall. (See Diagrams #5A, B & C, in the rear pages of the Rule Book).

B. An angled lower front firewall panel must connect the bottom of the front firewall vertical section to the front edge of the right floor pan at a point six (6) inches rearward of the vertical front firewall. This angled panel must fill the area between the transmission tunnel opening and the right main frame rail.

A second angled lower front firewall panel must connect the bottom of the front firewall vertical section to the front edge of the left front floor pan at a point not less than six (6) inches rearward and not more than 8-1/2 inches rearward of the vertical front firewall. This angled panel must fill the area between the transmission tunnel opening and the left main frame rail (see Diagrams #5A, B & C, in the rear pages of the Rule Book).

C. The use of vertical front firewall extensions is highly recommended. If used the vertical front firewall extensions must meet the following specifications:

A minimum 0.027 inch thick magnetic sheet steel vertical front firewall extensions must be attached to the vertical front firewall and fill the area between the vertical front firewall, rocker panels and flush with the inside surface of the front fenders rearward of the wheel opening and to the top of the vertical front firewall. Only one (1) radius (concave) will be permitted between the vertical front firewall and the inside vertical surface of the front fenders.

D. The use of vertical front firewall end panels is highly recommended. If used the vertical front firewall end panels must meet the following specifications:

A minimum 0.027 inch thick magnetic sheet steel vertical front firewall end panel must be welded in place to connect and seal the left and right ends of the vertical front firewall and lower angled panels to the left and right front roll bar legs (#2A & B).

E. It is required that one (1) of the vertical front firewall recommendations (extensions or end panels) as described in "B" or "C" above must be used. The use of both is highly recommended.

F. A tunnel opening must be cut near the center of the vertical front firewall and the lower angled panels. The tunnel opening must be 15 inches wide at the bottom where it meets the floor and must not be wider than 15 inches at any point. The left side of the tunnel opening must be located a maximum of six (6) inches from the longitudinal centerline of the frame. The top edge of the tunnel opening must be four (4) inches above the top of the vertical front firewall lower angled panels (see Diagrams #5A, B & C, in the rear pages of the Rule Book). A radius will not be permitted at the edge of the tunnel opening. The top of the tunnel opening must be cut in an arc and must not be flat at the top.

G. A front firewall to windshield filler panel, constructed using magnetic sheet steel a minimum of 0.027 inch thick, must be welded to the top edge of the front firewall vertical section and fill the area between the top of the front firewall vertical section and the bottom edge of the windshield.

20C – 3.4.2 Transmission Tunnel

A tunnel may be cut into the center of the front firewall, but the tunnel must not be wider than 18 inches at the bottom and the top of the tunnel must be at least 10 inches below the leading edge of the windshield.

When the NASCAR-approved (Generation 5) frame and roll cage assembly is used it must meet the following specifications. Modifications to any of the specifications or components will not be permitted.

A transmission tunnel constructed using magnetic sheet steel, a minimum of 0.027 inch thick, must connect the transmission tunnel opening in the front firewall to the front edge of the drive shaft hoop assembly. The transmission tunnel must remain flat and straight from the top of the front firewall tunnel opening to the front of the drive shaft hoop assembly. The left and right sides of the transmission tunnel must remain flat and straight from the sides of the front firewall tunnel opening to the front of the drive shaft hoop assembly (see Diagrams #5A, B & C, in the rear pages of the Rule Book).

20C – 3.4.3 Drive Shaft Tunnel

The drive shaft tunnel must not be more than 10 inches wide, when measured at the rear suspension cross member rearward and must be centered within plus or minus (+/-) one (1) inch and remain parallel to the main frame rails. The top of the drive shaft tunnel must remain parallel to the main frame rails at a maximum height of seven (7) inches above the top of the rear suspension crossmember.

When the NASCAR-approved (Generation 5) frame and roll cage assembly is used it must meet the following specifications. Modifications to any of the specifications or components will not be permitted.

The front drive shaft hoop assembly must be installed in the center of the trailing arm crossmember, between the left side and right side main frame rails and will consist of two (2) drive shaft tunnel plates constructed of magnetic steel flat plate with a minimum thickness of 0.114 inch and two (2) drive shaft hoops constructed of two (2) inch wide by 6-1/2 inch outside diameter magnetic steel flat plate with a minimum of 0.235 inch (see Diagram #1C, in the rear pages of the Rule Book).

The tapered drive shaft housing must be welded to the rear surface of the rear drive shaft tunnel plate. The tapered drive shaft housing must be constructed using 14 gage magnetic sheet steel. The tapered drive shaft housing minimum material thickness must be 0.065 inch and the maximum material thickness must not be more than 0.080 inch. The tapered drive shaft housing must be 8-3/4 inches high at the front and 12-3/4 inches high at the rear. The tapered drive shaft housing must be 34 inches long on the top, 32-1/4 inches long on the bottom, and six (6) inches wide. The sides of the tapered drive shaft housing must remain flat and perpendicular to the inspection surface with the top and bottom rolled on a three (3) inch radius for the entire length of the tunnel. The top surface of the tapered drive shaft tunnel rises from the front of the tapered drive shaft housing to the bottom of the horizontal tunnel bar (#6) and must be welded to the horizontal tunnel bar (#6). The rear of the tapered drive shaft housing must be welded to the vertical support tubes welded to the bottom of the horizontal tunnel bar (#6), and to the left and right sides of the tunnel under the horizontal tunnel bar (#6). These vertical support tubes must be made from one (1) inch by one (1) inch by seven (7) inch long square tubing with a minimum wall thickness of 0.110 inch. The bottom six (6) inches of the tapered drive shaft housing must be removable as one-piece for the entire length of the housing. A one (1) inch flange folded the entire length of both sides of the upper and lower housing sections must be used to bolt the housing together using six (6) evenly spaced 1/4 inch diameter bolts on each side (see Diagram #1C, in the rear pages of the Rule Book).

20C – 3.4.4 Floor Pan

Floor pans must be complete and welded in the standard position. Floor pans must be installed a minimum of one (1) inch above the lower edge of the main frame rails. The rear edge of the floor pan must not extend beyond the rear of the main frame rails. Air directional devices, including but not limited to tunnels and air ducts, unless otherwise specified by ARCA Officials, will not be permitted. Standard factory manufactured and/or fabricated floor pans will be permitted. When a fabricated floor pan is used it must be magnetic sheet steel, with a minimum thickness of 0.027 inch with all seams welded.

When the NASCAR-approved (Generation 5) frame and roll cage assembly is used it must meet the following specifications. Modifications to any of the specifications or components will not be permitted.

Floor pans must be complete and must be located parallel to the main frame rails. The completed floor pan must be fabricated in three (3) floor pan sections as described below. All floor pans must be acceptable to ARCA Officials.

A. The right side floor pan must be constructed using magnetic sheet steel with a minimum thickness of 0.027 inch with welded seams. The right side floor pan must start at a point four (4) inches rearward of the front of the right main frame rail and continue rearward a distance of 59 inches. The front and rear edge of the right side floor pan must be welded to the front and rear firewalls. The right side floor pan must lay flat on top of the trailing arm crossmember and be welded to the crossmember. The inside edge of the right side floor pan must be welded to the right side of the transmission tunnel and the tapered drive shaft housing. The outside edge of the right side floor pan must bend 90 degrees down to the inside surface of the right side main frame rail. This folded edge must locate the floor panel two (2) inches above the top of the right side main frame rail for the entire length of the right side floor panel. This right side edge must be welded to the right side main frame rail. The front and rear edges of the right side floor pan must be perpendicular to the inside of the right side main frame rail and must be parallel to each other (see Diagrams #5A, B & C, in the rear pages of the Rule Book).

B. The left side floor pan forward section must be constructed using a one (1) inch thick panel, constructed of 0.930 inch thick aluminum honeycomb core bonded between two (2) pieces of magnetic sheet steel with a minimum thickness of 0.027

inch. This aluminum honeycomb core must be 1/2 inch cell and of 60 psi strength minimum. As an option, magnetic sheet steel with a minimum thickness of 0.114 inch, may be used. The left side floor pan must be constructed using a section forward of the trailing arm crossmember and a section rearward of the trailing arm crossmember.

The left side floor pan forward section must start at a point a minimum of 3-3/4 inches and a maximum of 7-1/2 inches rearward of the front edge of the left side main frame rail and continue rearward to the trailing arm crossmember and be welded to the top of the trailing arm crossmember. A minimum floor pan width of 15 inches must be maintained from the inside of the left side main frame rail to the trailing arm diagonal brace at the trailing arm crossmember. The front edge of the left forward floor pan must end in a line perpendicular to the inside wall of the left side main frame rail and must be welded to the front firewall. The left front floor pan section must be flat and straight for the entire length of the panel. The left side of the left forward floor pan must be welded to the inside wall of the left side main frame rail. The right side of the left forward floor pan must be welded to the left side of the transmission tunnel (see Diagrams #5A, B & C, in the rear pages of the Rule Book).

C. The left side floor pan rearward section must be constructed using a one (1) inch thick panel, constructed of 0.930 inch thick aluminum honeycomb core bonded between two (2) pieces of magnetic sheet steel with a minimum thickness of 0.027 inch. This aluminum honeycomb core must be 1/2 inch cell and of 60 psi strength minimum. As an option, magnetic sheet steel with a minimum thickness of 0.114 inch, may be used. The left side floor pan rear section must start at and be welded to the back vertical surface of the trailing arm crossmember and continue rearward and be welded to the rear firewall, oil tank encasement and battery box. The left side of the left rear floor pan must be welded to the inside wall of the left side main frame rail. The entire left rear floor pan section must be a minimum of 1-1/16 inches above the bottom surface of the left main frame rail. The right side of the left rear floor pan must be welded to the left side of the tapered drive shaft housing. The left rear floor pan may contain a clearance panel for the left trailing arm beneath the seat and the horizontal tunnel bar (#6). The left rear floor panel may contain a battery box as described in sub-section 20C-6.5 (see Diagrams #5A, B & C, in the rear pages of the Rule Book).

20C – 3.4.5 Rear Firewall / Oil Reservoir Tank Encasement

A. A rear firewall (including any removable panels or access doors), constructed using magnetic sheet steel with a minimum thickness of 0.027 inch, must be located between the trunk area and the driver's compartment and must be welded in place. Carbon fiber or aluminum block-off plates/covers will not be permitted. Removable block-off plates/covers must be sealed at all times during competition. The rear firewall, as viewed from left to right, must be straight and flat between the rear sub-frame rails.

B. The rear firewall may extend vertically from the rear of the floorboard, at the horizontal tunnel bar (#6), up to a break or radius and then create an angled panel from the vertical rise to the front of the rear jacking bolt crossmember. The vertical rise must not start higher than the horizontal tunnel bar (#6). As an option the rear firewall may have an angled panel from the rear of the floorboard upward to the front of the rear jacking bolt crossmember. A second horizontal rear firewall must be used to seal the remaining area from the rearward edge of the rear jacking bolt crossmember to the rear window mounting bed. This panel may have a step for minimal clearance of the rear shock absorber mounting crossmember. The rear firewall must not be an integral part of the lubrication oil reservoir tank encasement. All rear firewalls must be acceptable to ARCA Officials.

When the NASCAR-approved (Generation 5) frame and roll cage assembly is used it must meet the following specifications. Modifications to any of the specifications or components will not be permitted.

A rear firewall (including any removable panels or access doors) constructed using magnetic sheet steel with a minimum thickness of 0.027 inch, must be located between the trunk area and the driver's compartment and must be welded in place. Block-off plates/covers used in rear firewalls in place of blowers, oil coolers, etc., must be constructed of magnetic sheet steel with a minimum thickness of 0.027 inch. Block-off plates/covers must be installed with positive fasteners and sealed to prevent air leakage. Carbon fiber or aluminum block-off plates/covers will not be permitted. The rear firewall must extend at an angle from the rear of the floor pans, as described in sub-section 20C-3.3, to the top front edge of the rear jacking bolt crossmember. The angled panel must be flat; bends, breaks, or radii will not be permitted. The top surface of the flat angled rear firewall panel may include one (1) break to align the panel with the top forward edge of the jacking bolt crossmember. This break must be located not more than five (5) inches forward of the center of the rear jacking bolt mounting sleeve.

A magnetic steel inner crush panel with a minimum thickness of 0.027 inch must fill the area between the outer vertical surface of the main roll bar (#1) and the inside surface of the left and right side door panels, and from the rocker panels to the door top.

The angled rear firewall must be constructed on the left side to locate the lubrication oil reservoir tank encasement. The lubrication oil reservoir tank encasement must be constructed using magnetic sheet steel with a minimum thickness of 0.027 inch and must be welded in place.

The lubrication oil reservoir tank encasement must be located behind the driver's seat but forward of the rear jacking bolt crossmember. The left side of the lubrication oil reservoir tank encasement must be located to the right of the outside edge of the left side rear sub-frame rail. The right side of the lubrication oil reservoir tank encasement must not be located further to the right than the longitudinal centerline of the frame rails. The lubrication oil reservoir tank encasement must not measure more than 15 inches wide by 15 inches long. The lubrication oil reservoir tank encasement and flat cover may be a maximum of four (4) inches higher than horizontal shoulder bar (#7) and may not be lower than the top surface of horizontal shoulder bar (#7). The lubrication oil reservoir tank encasement cover must be constructed using magnetic sheet steel with a minimum thickness of 0.027 inch.

The lubrication oil reservoir tank encasement flat cover must be secured to the top of the encasement, using 1/4 inch diameter bolts with a maximum of four (4) inch on center spacing, for the entire perimeter of the cover. Quick release fasteners will not be permitted. As an option, the lubrication oil reservoir tank encasement flat cover may be secured to the top of the encasement, using stitch welds with a maximum of four (4) inches on center spacing, for the entire perimeter of the cover.

The lubrication oil reservoir tank encasement flat cover must be bolted in place and remain securely fastened to the top perimeter of the lubrication oil reservoir tank encasement at all times during competition. Teams must take any steps necessary to ensure the integrity of the sealing of the oil reservoir tank flat cover to the top perimeter of the lubrication oil reservoir tank encasement, regardless of situations and/or conditions. Hoses and/or vents will not be permitted on the oil reservoir tank encasement.

A 41 inch wide horizontal rear firewall must be used to seal the remaining area from the top rear edge of the rear jacking bolt crossmember to the rear window mounting bed between the wheel wells. The panel must continue to rise and step above the rear shock absorber crossmember and must remain parallel to the construction surface. This step must not be higher than the top surface of horizontal shoulder bar (#7) and must not be more than six (6) inches below the top surface of horizontal shoulder bar (#7). The vertical section of the rear firewall located at the forward fuel cell mounting crossmember must remain flat and straight; bends, breaks, or radii will not be permitted for its entire 41 inch width. All rear firewalls must be acceptable to ARCA Officials (see Diagrams #5A, B & C, in the rear pages of the Rule Book).

An upper rear firewall (package tray) constructed of magnetic steel with a minimum thickness of 0.027 inch must be welded to the rear firewall above or rearward of the rear shock absorber crossmember to completely seal the area between the rear quarter panels/"C" posts above the rear wheel wells, the rear window, and the rear fire wall between the rear wheel wells. The upper rear firewall (package tray) must be welded to the back edge of the rear horizontal surface. The upper rear firewall (package tray) must remain flat and straight from front to back and be welded to the lower rear window support at the front of the deck lid. One (1) break will be permitted in the upper rear firewall (package tray). This break must only be located between the left side and right side deck lid mounting hinges. The upper rear firewall (package tray) must also be welded to the respective rear wheel well and sealed to the quarter panels/"C" posts on each end. Aluminum crush panels will not be permitted above the rear wheel wells at the quarter panels/"C" posts.

20C – 3.4.6 Rear Wheel Wells / Trunk Floor

A. The trunk compartment floor pan must be made of welded sheet steel and remain flat and level with the top of the frame rails and extend to within eight (8) inches of the rear quarter panels on the side. The rear crush panel between the rear frame crossmember and the rear bumper cover must be metal and may extend from the top of the rear frame crossmember to the top of the rear bumper cover. The rear crush panel must remain flat; bends, breaks or radii will not be permitted. The rear crush panel must be a minimum of one (1) inch above the bottom of the rear bumper cover.

B. The inner wheel well must be magnetic sheet steel and enclosed front and rear and installed as to separate the driver's compartment. The inner wheel well must follow the radius of the wheel opening. The wheel well radius will start at the bottom of the main frame rail and end at the top of the rear sub-frame rail within 25 inches of the rear axle housing. An aluminum crush panel must be installed between the inner wheel well and sealed to the rear quarter panel but must not exceed eight (8) inches in width. The crush panel attached to and sealed to the sides of the trunk floor must remain flat and level with the top of the rear sub-frame rails.

When the NASCAR-approved (Generation 5) frame and roll cage assembly is used it must meet the following specifications. Modifications to any of the specifications or components will not be permitted.

A. The inner rear wheel well panels must be constructed of magnetic steel with

a minimum thickness of 0.027 inch, and enclosed front and rear. These panels must be installed as to separate the driver's compartment from the rear wheel wells. The inner rear wheel wells must be constructed using flat (from left to right) magnetic sheet steel with a minimum thickness of 0.027 inch. The inner rear wheel well must follow the radius of the rear wheel opening. The rear wheel well radius must start at the bottom of the main frame rail and end at the top of the rear sub-frame rail within 25 inches of the rear axle housing. The rear wheel well radius, at its highest point, must not be more than 17 inches above the top of the rear sub-frame rear side rails. For its entire length, the outer edge of the right side and left side inner rear wheel well must be located 29 inches from and parallel to the chassis longitudinal centerline. A flat (from left to right) aluminum crush panel must be installed between the inner rear wheel well and sealed to the rear quarter panel but must not exceed 9-1/2 inches in width. The flat aluminum crush panel on the forward edge of each wheel opening may be installed at an angle, rearward, from the magnetic steel wheel tub to the wheel opening for a maximum height of 15 inches above the respective rocker panel.

B. The trunk compartment floor pan is comprised of the following six (6) sections: left, right and rear floor pan sections, and left, right and rear crush panels. The trunk compartment floor pan must be constructed using magnetic sheet steel with a minimum thickness of 0.027 inch welded in place and remain flat and level with the top of the frame rails. For its entire length, the outer edge of the right side and left side trunk compartment floor pan must be located 29 inches from and parallel to the chassis longitudinal centerline. The crush panel attached to and sealed to the sides of the trunk floor must remain flat and level with the top of the rear sub-frame rails.

The rear crush panel, between the rear sub-frame rear crossmember and the rear bumper cover, must be metal and must extend from the top rear edge of the rear sub-frame rear crossmember to the rear bumper cover. The rear crush panel must attach in a secure manner to the rear bumper cover. When attaching the rear crush panel to the rear bumper cover, the crush panel must not be less than 3-1/2 inches above the bottom of the rear bumper cover measured at the chassis longitudinal centerline. The rear crush panel must remain flat; bends, breaks or radii will not be permitted.

20C - 3.5 Doors

A. The door panels must remain as manufactured and be from the approved manufacturer. The manufacturer's label must remain visible and unaltered. All door panels must be securely fastened to the front fender and rear quarter panel.

B. All door seams must remain visible.

C. One door brace from the frame/roll cage assembly to the inside of the door panel will be permitted. The door brace must be mounted horizontally with a maximum length of 18 inches. The door brace may be in contact with the door panel but must not be attached to the door panel. Door bracing must be acceptable to ARCA Officials.

20C - 3.6 Fenders / Quarter Panels / Rocker Panels

A. The front fenders and rear quarter panels must remain as manufactured and be from the approved manufacturer. The manufacturer's label must remain visible and unaltered. All front fenders and rear quarter panels must be installed in their standard location as referenced by the ARCA-approved model vehicle. The outer edge of the lower air dam and front fenders must not extend beyond the limits of the ARCA measuring device(s). All quarter panels must remain as manufactured. The quarter panels must be vertically convex and horizontally straight. The tires and wheels must remain inside the body, except as specified in this sub-section. At the trailing edge of the front wheel openings, the front fenders may be stiffened by adding a wheel opening support. The support must not extend more than one (1) inch inboard and one (1) inch rearward of the wheel opening. The wheel opening support must not exceed 16 inches in height measured from the bottom of the fender, up the wheel opening.

B. The rocker panels must be installed straight and flush with the bottom of the frame rails and extend outward to the inside lower edge of the body. Rocker panels must be constructed using a minimum thickness of 0.025 inch and maximum thickness of 0.027 inch magnetic sheet steel. The rocker panels must completely fill the area between the main frame rails and the lower edge of the body for the entire length of the main frame rails. Notching of the rocker panels for the exhaust pipes will not be permitted.

C. The distance from the left side rocker panel to the right side rocker panel when measured at the front must be 73 inches and 75 inches at the rear. The rocker panels on both the left side and the right side must be evenly spaced from the longitudinal centerline of the chassis.

D. Modifications to any of the body panels that in the judgment of ARCA Officials are excessive will not be permitted.

E. All vehicles will be required to have installed a vertical extension flush with the outer body panel, at the bottom, on both right and left rocker panels. The extensions must be the same front to rear length as the rocker panel, cut only for exhaust and jack clearance, with a minimum of four (4) inches ground clearance on

the right side and a minimum of three (3) inches ground clearance on the left side. The lower portion of the extension must be constructed of a plastic type material with a maximum thickness of 3/16 inch. The distance from the left side rocker panel vertical extension to the right side rocker panel vertical extension when measured from the outside at the front lower sections must be between 73 inches and 73-1/4 inches and must be between 75 inches and 75-1/4 inches when measured from the outside at the rear lower sections. At road course Events, the minimum ground clearance on both the right and the left side vertical extensions must be three (3) inches.

F. The distance from the left side quarter panel to the right side quarter panel, when measured at the lower most trailing edge of the rear wheel opening, must be 73 inches. The quarter panels on both the left side and right side must be evenly spaced from the longitudinal centerline of the chassis.

G. All braces used to support fenders and quarter panels must be straight. All bracing must be constructed using a minimum of 3/8 inch magnetic steel tubing. The braces may be adjustable on one end (heim joint or slotted), the opposite end must be fixed with no adjustment.

H. A rear quarter brace (see diagram #11 in the rear pages of the Rule Book) must be installed in front of the right rear tire. The brace must be installed a maximum of 1/2 inch forward of the rear wheel opening and the lower edge of the brace must not be higher than 1-1/2 inches above the rocker panel. An optional rear quarter panel brace may be installed in front of the left rear tire.

I. One (1) rear quarter panel brace from the frame/roll cage assembly to the inside of the rear quarter panel behind the rear tire will be permitted. The rear quarter panel brace must be mounted horizontally with a maximum length of 12 inches. The rear quarter panel brace may be in contact with the rear quarter panel but must not be attached to the rear quarter panel. Rear quarter panel bracing must be acceptable to ARCA Officials.

J. At the trailing edge of the rear wheel openings, the rear quarter panels may be stiffened by adding a wheel opening support. The support must not extend more than one (1) inch inboard and one (1) inch rearward of the wheel opening. The wheel opening support must not exceed 10 inches in height measured from the bottom of the rear quarter panel, up the wheel opening.

20C - 3.7 Grilles

A. All lower grille openings must remain as manufactured from the approved manufacturer without any modifications for the model being used. Unless approved by the Series Director.

B. The simulated upper grille opening in the approved front bumper cover must not be altered or opened for radiator air entry.

C. The grille opening must be covered with one (1) or two (2) layers of screen wire or perforated metal attached to the bumper cover. A one (1) inch wide metal strip to hold the screen wire to the bumper cover may be installed only on the outer edges of the grille opening. All grille opening coverings must be acceptable to ARCA Officials.

D. Approved lower grille inserts will be permitted. The following are the only approved lower grille inserts:

<u>YEAR</u>	<u>MODEL</u>	<u>FIVE STAR RACE CAR BODIES</u>
		<u>Air Inlet Bezel</u>
2014	Chevrolet SS	Inlet built in front bumper cover
2014	Ford Fusion	Part # 14311- 46712
2014	Toyota Camry	Part # 14711- 46712
		<u>Air Inlet Close Out</u>
2014	Chevrolet SS	Part # 14121- 46611
2014	Ford Fusion	Part # 14311- 46611
2014	Toyota Camry	Part # 14711- 46611

E. For radiator air inlet specifications refer to sub-section 20C-7.3.

20C - 3.8 Hood / Roof

A. The hood and roof must remain as manufactured and be from the approved manufacturer. The manufacturer’s label must remain visible and unaltered. ARCA Officials may use hoods and roofs provided by the respective manufacturer as a guide in determining whether a Competitor’s hood and roof conforms to the specifications of the ARCA Rule Book.

B. The hood location must be acceptable to ARCA Officials.

C. The hood must be equipped with heavy-duty metal hinges and metal self-holding devices on both the left and right sides to support the hood when open. When the hood is closed, it must be secured with a minimum of four (4) positive magnetic solid steel pin fasteners, of a minimum 3/8 inch diameter, equipped with clip cables evenly spaced across the front. All removable hood pins must be a minimum of 1/8 inch diameter and must have a minimum one (1) inch inside diameter

vertical loop to facilitate ease of removal. Metal hood pin bezels must be installed at all times. Recessed hood pin plate bezels will not be permitted.

D. The hood must be connected to the roll cage using a Vectran HS V-12 fiber cable on the left and right sides on the underside of the hood. The fiber cable must be constructed from a continuous loop of 1/4 inch diameter 12 strand cable (with a red tracer thread) woven from Vectran HS V-12 fiber. The fiber cables must be attached to the tether mounting loops on the underside of the hood on both the left side and right side. The fiber cables must attach to the hood using the Harken 8mm High Resistance D Shackle part #2116. The D shackle must be installed with the "U" shaped part of the shackle going through the loop at the end of the fiber cable and the shackle pin going through the tether mounting loop on the underside of the hood. Once attached, the shackle pin must be safety wired.

The Vectran cable must wrap around the front sub-frame bars (#16 A & B) forming a choke type hitch where one end passes through the loop after wrapping around the front sub-frame bars (#16 A & B) or be attached to the front sub-frame bars (#16 A & B). When the hood supports are removed and the hood is laid back towards the top of the windshield, the cables must be taut. Steel cables will not be permitted.

E. On all tracks, vehicles must have the approved hood with fully operational hinged trap doors (hood flaps) installed except when the approved "Spec Engine" is used at ARCA West Series stand-alone and ARCA West Series combination Events. The hinged trap doors (hood flaps) must be ARCA-approved and obtained only through ARCA-approved sources. When used the hood and hinged trap doors (hood flaps) must remain as manufactured. Springs that hold the hinged trap doors (hood flaps) closed will not be permitted. The ARCA-approved hinged trap doors (hood flaps) are listed below:

<u>MODEL</u>	<u>PART NUMBER</u>
Chevrolet SS	14121-34512L
	14121-34512R
Ford Fusion	14311-34512L
	14311-34512R
Ford Mustang	14321-34512L
	14321-34512R
Toyota Camry	14711-34512L
	14711-34512R

F. The roof panel (Greenhouse) must remain as manufactured and be from the approved manufacturer. Roof bracing, acceptable to ARCA Officials, must be used to maintain the approved roof shapes and heights. The roof braces may be adjustable (heim joint or slotted) on one end, the opposite end must be fixed with no adjustment.

G. A one-piece strip of aluminum angle 3/4 inch high by 3/4 inch wide, must be attached to the roof on both the right side and left side of the roof. The roof angle (roof rail) must not exceed a maximum thickness of 0.050 inch. The roof angle (roof rail) must be attached to the roof in the recessed area of the roof. The roof angle (roof rail) fasteners must be #10 button head bolts, acceptable to ARCA Officials. Button head rivets and the use of external back up washers will not be permitted. The roof angles (roof rails) must be painted.

H. On all tracks the rear portion of the roof panel (greenhouse) must be equipped with the approved fully operational hinged air deflectors (roof flaps) except when the approved "Spec Engine" is used at ARCA West Series stand-alone and ARCA West Series combination Events. The hinged air deflectors (roof flaps) must be ARCA-approved and obtained only through ARCA-approved sources. When used the hinged air deflectors (roof flaps) must be installed in the designated location in the roof panel (greenhouse) and must remain as manufactured. The hinged air deflectors (roof flaps) must be installed as specified in the instruction sheet supplied with the hinged air deflector (roof flap) kit. The internal balance port connecting the right and left air deflector trays must remain unobstructed and functional. When the hinged air deflectors (roof flaps) are not required, the hinged air deflectors (roof flaps) may be replaced with an approved hinged air deflector (roof flap) filler panel. The filler panel must be from an ARCA-approved source. The only approved filler panel is Five Star Race Car Bodies part # 14001-51912. The filler panel must remain as supplied and be installed as specified in the instruction sheet supplied with the filler panel. The installation of the filler panel must be acceptable to ARCA Officials.

The ARCA-approved hinged air deflectors (roof flaps) and sources are listed below:

<u>MANUFACTURER</u>	<u>PART NUMBER</u>
Five Star Race Car Bodies Phone: 262-877-2171	14001-51881
Roush Industries Dave Zajac Phone: 734-466-6348 Email: dave.zajac@roush.com	30-348-0032

I. A stationary air deflector must also be installed on the rear window on the left side. The rear window stationary air deflector must be attached using the double shear mounting flange and bolt requirements, as shown and described in Diagram # 10 in the rear pages of the Rule Book. The rear window stationary air deflector must match the height, length and contour of the ARCA R70-020 template. A minimal taper at the rear edge of the rear window stationary air deflector will be permitted to allow for the opening and closing of the deck lid. The rear window stationary air deflector must be constructed using 1/4 inch thick, clear polycarbonate. The rear window stationary air deflector mount must be oriented on the rear window so that the horizontal surface of the rear window stationary air deflector mount is inboard towards the longitudinal centerline of the vehicle. The mounting flange must not be lightened. The rear window stationary air deflector and the left side roof angle (roof rail) must be aligned and straight.

J. An optional roof hatch panel will be permitted as an alternate exit for the driver. When used, only the roof panels (greenhouses) designed for use with the roof hatch panel assembly will be permitted. The roof panel (greenhouse) must be from the approved manufacturer and remain as manufactured.

- a. The functional roof hatch assembly must be installed in accordance with the approved manufacturer's instructions. Modifications to the roof hatch release mechanism kit, including the addition, subtractions and/or alteration of any roof hatch kit piece(s) will not be permitted.
- b. Two (2) roof hatch panel tethers (P/N RH-101X16) will be required. The roof hatch tethers must wrap around the main roll bar (#1) forming a choke type hitch where one end passes through the loop after wrapping around the main roll bar (#1) and attaching to the rear roof hatch panel studs using 1/4 inch magnetic steel lock nuts and washers. No modifications to the tethers will be permitted.
- c. The roof hatch panel may be functional or fixed. If fixed, the front of the roof hatch panel must use the provided magnetic steel brackets attached to the front roof hatch panel studs using 1/4 inch magnetic steel lock nuts and washers. The magnetic steel brackets must securely engage the roof panel (greenhouse) and must be tightened so that the roof hatch panel remains air tight at all times.
- d. The roof hatch panel perimeter must remain flush with the roof at all times. The roof hatch panel seal must remain as manufactured without any modifications.

When the roof hatch option is used, it is the responsibility of the driver, not ARCA, to ensure that he/she is familiar with and proficient in the operation of the roof hatch. Drivers should practice operation of and egress through the roof hatch.

20C - 3.9 Rear Deck Lids

A. The rear deck lid must remain as manufactured and be from the approved manufacturer. The manufacturers label must remain visible and unaltered. ARCA Officials may use deck lids provided by the respective manufacturer as a guide in determining whether a Competitor's deck lid conforms to the specifications of the Rule Book.

B. The deck lid must be installed in operating condition. When closed, the deck lid must be sealed around the entire perimeter of the deck lid opening.

C. The deck lid must be held closed with two (2) positive, minimum 3/8 inch diameter, solid, magnetic steel pin fasteners equipped with clip cables, one (1) on each side. All removable deck lid pins must be a minimum of 1/8 inch diameter and must have a minimum one (1) inch inside diameter vertical loop to facilitate ease of removal. Metal deck lid pin bezels must be installed at all times. Recessed pin plate bezels will not be permitted.

D. The deck lid must have metal hinges acceptable to ARCA Officials.

E. The deck lid must have a metal self-holding device to keep the lid up when opened.

F. The deck lid must be connected to the trunk reinforcement bar (#14) using two (2) fiber cables, each constructed from a continuous loop of 1/4 inch diameter 12 strand cable (with a red tracer thread) woven from Vectran HS V-12 fiber. Each fiber cable must attach to a minimum 5/16 inch diameter bolt passing through the spoiler attachment plate with heavy-duty, two (2) inch diameter by 1/8 inch minimum thick flat metal washers and lock nuts, acceptable to ARCA Officials, on each side.

These bolts must be located between 12 inches to 15 inches inboard of the deck lid edge on each side. The remaining end of the cables must attach to the trunk reinforcement bar (#14) using a choke type hitch. One (1) cable must be used on the right side and one (1) on the left side of the deck lid.

G. A left side stationary air deflector must be installed on the rear deck lid at all times during competition. The deck lid stationary air deflector must be attached using the double shear mounting flange and bolt requirements, as shown in Diagram #10, in the rear pages of the Rule Book. The stationary deck lid air deflector must match the height, length and contour of the ARCA R70-020 template. The stationary deck lid air deflector must be constructed using 1/4 inch thick clear polycarbonate. The stationary deck lid air deflector mount must be orientated on the rear deck lid so that the horizontal surface of the stationary deck lid air deflector mount is inboard towards the longitudinal centerline of the vehicle. The stationary deck lid air deflector must be located parallel to and aligned straight with the rear window stationary air deflector and left side roof angle (roof rail). The stationary deck lid air deflector must be located to allow it to by-pass the inside vertical surface of the rear window stationary air deflector. The stationary deck lid air deflector must remain clear and must not have any paint, vinyl, decals and/or text applied on it.

20C - 3.10 Bumper Covers

A. The front and rear bumper covers must remain as manufactured and be from the approved manufacturer. The manufacturers label must remain visible and unaltered. ARCA Officials may use bumper covers provided by the respective manufacturer as a guide in determining whether a Competitor's bumper cover conforms to the specifications of the Rule Book. Unless otherwise authorized by the Series Director, cutting and reshaping of bumper covers will not be permitted.

B. The bumper covers, once installed, must fit all approved ARCA templates.

C. Front and rear bumper cover reinforcement bars must be installed and must be acceptable to ARCA Officials. The front bumper reinforcement bars must be constructed as a main horizontal bumper tube behind the bumper cover. The front bumper reinforcement bar must be constructed of a minimum one (1) inch outside diameter with a minimum wall thickness of 0.065 inch to a maximum of 1-3/4 inches outside diameter with a maximum wall thickness of 0.090 inch magnetic steel tubing. From the main horizontal bumper tube rearward there must be two (2) main bumper support tubes welded in place to connect the main bumper tube to the front sub-frame. Any front bumper cover reinforcement added to the return flange must not extend rearward beyond the trailing edge of the return flange. A maximum of three (3) front bumper cover reinforcement braces per side will be permitted. Reinforcement braces must be a maximum of 1-1/2 inch in width. The inner brace on both sides must maintain a minimum distance of one (1) inch from the inside edge of the brace to the outside edge of the lower panel below the radiator duct when measured at any point and remain open at all times. The rear bumper reinforcement bar must not be wider than the inside width of the rear bumper cover and must not extend forward along quarter panels. The rear bumper reinforcement bar must be constructed of a minimum one (1) inch outside diameter with a minimum wall thickness of 0.065 inch to a maximum of 1-3/4 inches outside diameter with a maximum wall thickness of 0.090 inch magnetic steel tubing. For inspection purposes, the rear bumper bar must remain uncapped and accessible for inspection from end to end. The rear bumper reinforcement bar must be attached to the rear sub-frame crossmember by welding a maximum of two (2) horizontal tubes of the same diameter or a minimum of one (1) inch outside diameter steel tube as used for the rear bumper reinforcement bar. Holes and/or other modifications in the rear bumper reinforcement bar or attaching bars that, in the judgment of ARCA Officials, were made with the intent of weight reduction will not be permitted.

D. The following is a list of approved front bumper covers:

<u>YEAR</u>	<u>MODEL</u>	<u>FIVE STAR RACE CAR BODIES</u>
2014	Chevrolet SS	14121-41011
2014	Ford Fusion	14311-41011
2014	Toyota Camry	14711-41011
2022	Ford Mustang	14321-41012

E. The following is a list of approved rear bumper covers:

<u>YEAR</u>	<u>MODEL</u>	<u>FIVE STAR RACE CAR BODIES</u>
2014	Chevrolet SS	14121-45011
2014	Ford Fusion	14311-45011
2014	Toyota Camry	14711-45011
2022	Ford Mustang	14321-45012

F. A front and rear tow strap may be used. The tow straps must be nylon webbing or similar material and must meet FIA requirements. The tow straps must be attached to the front and rear bumper reinforcement bars and installed per the

manufacturer's instructions. When used, the tow straps must be installed within an area of a maximum of fifteen inches in length and a maximum of four (4) inches in height to the left of the center line of the chassis, in the upper left lower grille area of the front bumper cover and the lower left flat area of the rear bumper cover. The opening must be as minimal as possible. The tow strap may extend one (1) inch from the bumper cover opening when not in use. Tow straps and installation must be acceptable to ARCA Officials.

20C - 3.11 Identification / Marking

A. Numbers / Graphics

1. All vehicle number configuration and design is subject to approval by the Series Director. Only single or double digit numbers will be permitted. **The size, color, and style of numbers must be adequate to permit prompt identification by ARCA Officials at all times.** Numbers must be a solid color, at least 21 inches high, measured vertically, excluding borders and silhouettes, must be neatly attached to or painted on both sides of the vehicle on the center of the door (except as described in B. 7. Below). Door numbers must be a minimum of four (4) inches in width and slant no more than 30 degrees from vertical. The tops and bottoms of all numbers must be even (not staggered). Two (2) digit numbers must not overlap. A solid number 36 inches high, excluding borders and silhouettes, must be neatly attached to or painted on the roof, reading from the driver's side. Door and roof numbers must be of a different color to most of the background paint scheme. Numbers that are of an outline or border only style will not be permitted. Solid numbers, as large as possible, must be attached to or painted on the right side outer headlight and taillight covers. The use of number decals is acceptable if ARCA Officials determine that the number is legible. Chrome and foil numbers may be approved, at ARCA's discretion. Paint schemes and decals using a mirrored or holographic appearance will not be permitted.
2. All ARCA vehicle numbers are owned by and will be assigned by ARCA for use by the car owner. Vehicle numbers are not transferable or assignable by the car owner. Numbers on a vehicle competing in these Series must correspond with the car owner's license that is on file at ARCA Headquarters, unless otherwise authorized by ARCA.
3. ARCA Officials may require a Competitor to use a different number in order to avoid duplication or confusion at an Event.

B. Decals / Advertising

1. ARCA may, in its sole discretion, refuse to permit for any reason, or it may restrict or assign the size or placement of decals, identification, and advertising of any kind including but not limited to the vehicle, equipment, personnel, uniforms, garage and pit areas, promotional materials, and/or support vehicles. All ARCA Members agree to accept ARCA's decision in this regard.
2. ARCA may refuse to permit a Competitor to participate in an Event if ARCA determines that any advertising, sponsorship or similar agreement to which the Competitor (or a car owner, driver or crew member associated with the Competitor) is or will be a party, is detrimental to the sport, to ARCA, Series Sponsor or to the Promoter for any reason, including without limitation, the public image of the sport.
3. Decals, advertising slogans, paint schemes and other graphic designs and text on the vehicle that have not been previously approved by ARCA must not be used unless and until they have been submitted by the crew chief to ARCA Headquarters and approved by ARCA prior to the Event. The review and approval of decals, advertising slogans, paint schemes and other graphic designs and text on the vehicle that have not been previously approved by ARCA is at the sole discretion of ARCA and such approval may be withheld for any reason. All ARCA Members agree to accept ARCA's decision in this regard.
4. Only the following vehicle markings will be permitted between the front of the vehicle and the front of the door:
 - a. Series sponsor vehicle markings;
 - b. ARCA contingency program sponsor vehicle markings;
 - c. Vehicle markings that appear in the background in a non-prominent step and repeat pattern that is approved by ARCA;
 - d. Vehicle markings that appear below the front grille in a pattern representing a single sponsor/brand approved by ARCA, provided they do not interfere with OEM markings;
 - e. Team name or logo placed under the headlight decal;
 - f. Such other vehicle markings as ARCA, in its sole discretion, may permit or require.
5. All decals or adhesive backed emblems supplied by ARCA contingency program sponsors for advertising or identification on ARCA race vehicles must be limited in size to the area of a 32 square inch rectangle. Decal sizes will be determined by multiplying the full width and full length of any

decal, regardless of the decal shape. Only decals of participating ARCA contingency program sponsors will be permitted.

6. Decals, advertising logos, text or identification of sponsors will not be permitted on the windshield (except Series Sponsor), rear window (except driver's last name), rear quarter windows or rear spoiler (except Series Sponsor and Official tire supplier).
 - **Teams are required to place a Series sponsor decal across the windshield as specified by ARCA.**
 - **Teams are required to place a Series sponsor decal across the front of the rear spoiler and an Official tire supplier decal across the rear of the spoiler as specified by ARCA. The front and rear of the rear spoiler must be the colors specified by ARCA.**
 - **Teams are required to place a decal with the driver's last name across the top of the rear window. The driver's last name must be centered on the decal. The decal must extend the full width of the upper rear window and must be black perforated vinyl five (5) inches in height. The driver's last name must be printed in Berthold Akzidenz Grotesk Extra Bold Condensed Italic Font in 3-1/2 inches high white text.**
7. Vehicle markings that appear along the rocker panel, below the door number will be permitted in a pattern representing a single sponsor/brand approved by ARCA, provided they do not interfere with OEM markings. A rectangular marking one (1) inch wide by three (3) inches high designating the jack post location will be permitted.

As an option, vehicle markings that appear on the door representing a single sponsor/brand will be permitted only when the vehicle number is placed on the rear quarter panel. The vehicle number when placed on the rear quarter panel must be at least 23 inches high and 23 inches in width, measured vertically and horizontally, excluding borders and silhouettes. Vehicle numbers and position must be approved by ARCA.

8. Decals, advertising logos, text or identification of sponsors, other than the 72 square inch identification for the automobile manufacturer, will not be permitted on the most rearward vertical portion of the rear bumper cover.
9. Decals, advertising logos, text or identification of sponsors must not extend past the seam between the hood and front fenders and the seam between the rear of the hood and the cowl.
10. One (1) vehicle marking (sponsor) with a maximum height of nine (9) inches will be permitted behind the roof number on the roof panel. Vehicle marking must be approved by ARCA.
11. A yellow stripe, a minimum of four (4) inches in height and 55 inches wide, must be displayed on the vertical portion of the rear bumper cover of any vehicle driven by a rookie driver as determined by the Series Director.
12. **Drivers and Crew Chiefs are required to have the mandatory Series sponsor and logo patches as specified on the Official Entry Blank and ARCA Menards Series Firesuit Logo guide permanently attached to the Drivers and Crew Chiefs uniforms at all times. Non-compliance will result in a penalty including not being allowed to participate in any on-track activities. It is highly recommended that all crew members display the Series logo on their uniform on race day.**

20C - 3.12 Vehicle Body Measurements

20C - 3.12.1 ARCA Templates

A vehicle must conform to any and all approved ARCA templates, comparison pieces, and/or other measuring devices as applied and measured by ARCA Officials. Once a vehicle has passed template inspection at an Event, the vehicle must not be altered in any manner that in the judgment of ARCA Officials enhances the aerodynamic performance of the vehicle.

20C - 4 GENERAL ENGINE REQUIREMENTS

20C - 4.1 General Engine Eligibility

A. The eligible engines must be production engines as determined, selected and approved by ARCA. All major components (engine block, heads, etc.) must be produced by the manufacturer for sale in a regular product offering. Prior to being used in competition, all major engine and component parts must be submitted, in a completed form/assembly, to the NASCAR R&D Center on or prior to September 3, 2024, for consideration of approval and approved by ARCA. Each such part may thereafter be used until ARCA determines that such part is no longer eligible.

B. As an option, Teams may compete with the ARCA/Ilmor engines supplied by Ilmor Engineering. If used, the engine must be completely assembled by Ilmor Engineering only and used without modifications by the Competitor. Part numbers and/or identification markings must remain as supplied without modifications. Painting, coatings, polishing, addition or removal of material of any kind will not be permitted to any engine part.

Ilmor Engineering, Inc.
43939 Plymouth Oaks Blvd.
Plymouth, Michigan 48170
Phone: 734-456-3653
Email: www.ilmor.com/en

C. As an option, Teams may compete with the Robert Yates Racing Engines "Spec Engine". The engine will be permitted on all tracks less than 1-1/2 miles in length and road courses. If used, the "Spec Engine" may be purchased as a completely assembled engine or purchased in kit form to be assembled by the engine builder of the team's choice. "Spec Engine" kits and assembled engines are available directly from Robert Yates Racing Engines, LLC. If used, the "Spec Engine" must be completely assembled using only approved "Spec Engine" components without any modifications. Part numbers and/or identification markings must remain as supplied without modifications. Painting, coatings, polishing, the addition or removal of material of any kind will not be permitted to any engine part. All parts, pieces and components that are used in the "Spec Engine" must originate from Robert Yates Racing Engines, LLC and remain as supplied.

Robert Yates Racing Engines, LLC
159 Bevan Drive
Mooresville, North Carolina 28115
Phone: 704-660-7015
Email: dlewis@ryr.com

The following modifications listed below are permitted to the approved "Spec Engine":

1. A bonding agent (epoxy) may be used to assist in adhering the emulsion tube plugs to the carburetor metering blocks, if needed to help prevent fuel leakage only. No other modifications to the carburetor metering blocks will be permitted.
2. An additional oil scavenge line from the second stage of the oil pump to the lubrication oil reservoir tank will be permitted. The additional oil scavenge line may merge into the oil scavenge line on the first stage of the oil pump.
3. The use of the crankcase windage tray supplied by the approved supplier is optional.
4. The installation and fitting of valve guide liners will be permitted. The valve centerline and valve angle must remain the same as supplied by the approved supplier and manufacturer.
5. The combustion chamber volume must be 64cc's for compression after the valve maintenance (valve job) has been completed.
6. Valve springs must be installed at 1.800 inches with an approximate seat pressure of 130 lbs.
7. A maximum cylinder overbore size of 0.010 inch will be permitted on the approved "Spec Engine" block. The 0.010 inch overbore pistons, piston rings and wrist pins must be purchased from the approved supplier with no modifications.
8. Decking (milling) of the engine block cylinder head surface to ensure proper sealing will be permitted. The engine block cylinder head surface may be decked (milled) up to a maximum of 0.005 inch. When installed the top of any piston must not be more than 0.015 inch at any point above the engine block cylinder head surface.

The following modifications listed below will not be permitted to the approved "Spec Engine":

1. Valve guide service with the exception of valve guide liner installation and valve seat replacement must only be completed by Robert Yates Racing Engines, LLC.
 - a. The following procedures and specifications must be followed when performing valve maintenance (valve job) on the "Spec Engine". No modifications or deviations from the procedures or specifications will be permitted.
 - b. There are two (2) approved methods of valve seat maintenance for the "Spec Engine".
 1. The use of a dedicated carbide cutting tool insert for the intake and exhaust valve seats is available only through **Robert Yates Racing Engines, LLC.**

INTAKE

Part number: WAR-IC-6527

EXHAUST

Part number: WAR-EC-6528

2. The programming and application of the supplied coordinates for use with the NEWEN Contour EPOC style machine using a single point cutter are available only through Robert Yates Racing Engines, LLC.

3. No modifications to the CAMSHAFT – CAMSHAFT TIMING must be to manufacturer's specified settings.

The use of a camshaft degree bushing will be permitted in the camshaft timing gear to obtain the manufacturer's camshaft timing specified settings. The manufacturer's camshaft timing specified settings for the intake centerline must be a minimum of 105.5 degrees and a maximum of 106.25 degrees. No other modifications to the camshaft timing will be permitted.

4. No header or collector modifications.
5. No ignition system modifications.

As an option, Teams will be permitted to use the crank trigger ignition system Part # 125004, available only through Robert Yates Racing Engines. If the crank trigger ignition system is being used, triggering devices or pick-ups will not be permitted inside the distributor housing. Teams will be permitted to use distributor Part # 187008 available only through Robert Yates Racing Engines with the crank trigger ignition system only.

6. No oil pan modifications.

As an option, Teams will be permitted to use the Moroso oil pan baffle insert, part number OILP-144004, available only through Robert Yates Racing Engines.

The ARCA Ilmor, Robert Yates Racing Engines "Spec Engine" and the ARCA-approved Built and Legacy engines may be interchanged with any Grand National-approved (Flange Fit) Composite Body model vehicle.

D. Unless otherwise specified by ARCA, the same long block engine assembly (engine block, crankshaft, camshaft, connecting rods, pistons, cylinder heads, and valves) must be used for the entire Event, including practice, qualifying and the Race. An engine must not be removed from a vehicle without the approval of the Series Director. The Series Director may require any team that removes an engine to start at the rear of the field, providing the vehicle earns a starting position in the Race. The engine may be removed from a back-up vehicle, without a penalty, at the discretion of the Series Director as follows:

1. If a vehicle is wrecked beyond repair in practice before qualifying and a back-up vehicle is used, then an engine change may be permitted provided the change can be accomplished in a timely manner before qualifying.
2. If a vehicle is wrecked beyond repair during qualifying and a back-up vehicle is used, an engine change may be permitted, however, the engine change must be completed before the beginning of practice(s), if practice(s) is scheduled following qualifying.
3. If a vehicle is wrecked beyond repair after qualifying and a back-up vehicle is used, then an engine change may be permitted without an additional penalty.

If a Competitor violates this Rule, in addition to imposition of a penalty pursuant to Section 12, the Series Director may take appropriate action during the Event, including but not limited to loss of practice time and/or loss of the opportunity to qualify and/or confiscation of the engine or engine components. Such action shall be deemed an inspection decision not subject to Section 12.

In an effort to save time during at track inspections, all built engines must have the forward most right side and forward most left side intake manifold bolts and the forward most right side and forward most left side lower cylinder head bolts cross drilled for engine sealing. If cylinder head studs are used, the studs must be cross drilled above the cylinder head nut or through cylinder head nut and stud. The holes must be drilled a minimum diameter of 0.063 inch to accept the ARCA engine seal.

All ARCA/Ilmor engines will have seals applied by Ilmor Engineering. Competitors must not remove, alter or tamper with the engine supplier seal. If a Competitor presents an ARCA/Ilmor engine for Competition with a broken, missing or altered engine supplier seal, the engine will not be eligible for use at that Event and will be impounded by ARCA.

All approved "Spec Engines" must have the forward most right side and forward most left side intake manifold bolts, the forward most right side and the forward most left side lower cylinder head bolts and the right side and left side (second from bottom) front timing cover bolts cross drilled for engine sealing. The holes must be drilled a minimum diameter of 0.063 inch to accept the ARCA engine seal.

The right side front carburetor/Throttle Body stud must be drilled a minimum diameter of 0.063 inch to accept the ARCA carburetor/Throttle

Body seal on all engines. All built engines must have the closest intake manifold bolt to the drilled carburetor stud drilled a minimum diameter of 0.063 inch to accept the ARCA carburetor/Throttle Body seal.

20C - 4.2 General Engine Characteristics

The following characteristics of the production engine must be maintained in any engine used in competition in a manner acceptable to ARCA Officials. All parts listed below must originate from approved production castings and forgings. All parts, except spark plugs, should utilize fractional English measurement system fasteners and dimensions (non-metric).

A. ENGINE BLOCK:

Material
Number of Cylinders
Angle of Cylinders
Cylinder Bore Centerline Spacing
Number of Main Bearings and Type
Number of Camshaft Bearings and Type
Integral or Separate Cylinder Sleeves
Location of Camshaft
Overall Configuration

B. CYLINDER HEAD:

Material
Number of Valves per Cylinder
Type of Combustion Chamber
Location of Spark Plug
Orientation of Spark Plug
Arrangement of Valves
Valve Location in Relation to the Cylinder Bore
Angle of Valves
Type of Valve Actuation
Number of Intake Ports
Number of Exhaust Ports
Center Distances of Intake Ports Referenced to the Cylinder Bore
Center Distances of Exhaust Ports Referenced to the Cylinder Bore
Angle of Port Face Relative to Mating Face of Head to Block
Firing Order

20C - 5 DETAILED ENGINE REQUIREMENTS

For purposes of construction, some elements of sub-section 20C-5 are listed below. Changes from the ARCA-approved standard production automobiles or component parts will not be permitted except as specified in the following Rules for engine preparation. In addition to the General Engine Requirements specified in sub-section 20C-4, the engines must also conform to the following Detailed Engine Requirements.

20C - 5.1 Engine Location

A. All currently approved engines must be located 9-1/2 inches (+/-) one (1) inch forward of the base of the windshield when measured from the carburetor/throttle body air filter housing mounting stud to the base of the windshield at the center.

B. The longitudinal centerline of the crankshaft must be in the longitudinal centerline of the front sub-frame.

20C - 5.2 Engine Ground Clearance

The engine ground clearance when measured from the center of the leading edge of the crankshaft accessory drive bolt must maintain a minimum of 10 inches and a maximum of 12 inches for all currently approved engines. Nothing may be located directly forward or below the front end of the crankshaft that would interfere with the engine ground clearance inspection.

20C - 5.3 Engine Mounts

- A. All engine mounts must be reinforced steel or aluminum.
- B. Front to rear, adjustable engine mounts will not be permitted.

20C - 5.4 Engine Displacement / Compression Ratio

A. Engine Displacement

Only "small block" V-8 engines with a minimum of 350.000 cubic inch displacement and a maximum of 360.000 cubic inch displacement will be permitted.

The only basic engines designated and approved as "small block" engines are:

DODGE
360 CID

FORD
351C CID

GENERAL MOTORS
350 CID

Engine displacement may be increased or decreased by changing the cylinder

bore diameter and/or the crankshaft stroke length. The total cubic inch displacement must not be less than the minimum engine size of 350.000 cubic inch displacement or greater than the maximum engine size of 360.00 cubic inch displacement.

The formula for determining the cubic inch displacement is as follows: Bore x Bore x Stroke x .7854 equals the cubic inch displacement of each cylinder. The cubic inch displacement of each cylinder added together will determine the total cubic inch displacement of the engine.

Unless otherwise permitted by ARCA Officials, a maximum cooling down time of two (2) hours from the official completion time of the Race will be permitted prior to measuring the total cubic inch displacement.

B. Compression Ratio

For all Events, the maximum allowable compression ratio permitted on any cylinder will be 12.0 to 1 on all ARCA-approved Built and Legacy engines. When calculating the compression ratio, an allowance of one (1) cubic centimeter will be added to the volume for the area around the top of the piston down to the top of the piston ring that will be sealed with grease.

The procedure for calculating the compression ratio is as follows: Bore x Bore x Stroke x .7854 x 16.387 equals the Cylinder Volume of a cylinder at Bottom Dead Center (BDC) in cubic centimeters. The Cylinder Head Pour Volume minus (-) the known volume of the cylinder head plate plus (+) Head Gasket Volume plus (+) 1.00 cc for sealing the piston ring plus (+) the Cylinder Block Volume minus (-) the known volume of the block plate equals (=) Chamber Volume.

$$\text{Compression Ratio} = \frac{\text{Cylinder Volume plus (+) Chamber Volume}}{\text{Chamber Volume}}$$

20C - 5.5 Engine Blocks

All engine blocks must be acceptable to ARCA Officials and meet the following requirements. ARCA Officials may use an engine block provided by the respective manufacturer as a guide in determining whether a Competitor's engine block conforms to the specifications of the Rule Book.

20C - 5.5.1 Eligibility

A. Engine blocks must be a product of the manufacturer for the ARCA-approved engine being used in competition. Approved manufacturers identification and part numbers and/or casting numbers in the form of cast-in numbers must remain unaltered on the engine block being used in competition.

B. Only the Dodge R5 engine blocks, the Ford 351 Cleveland-type engine blocks, the General Motors 350 engine blocks and the General Motors SB2 engine blocks will be permitted. Aftermarket engine blocks will not be permitted.

C. The engine block must retain all standard external dimensions with the exception of the surfacing of the engine block deck. Angle cutting of the engine block deck will not be permitted.

D. Engine blocks must use individual magnetic steel crankshaft main bearing caps. The main bearing bore size must be the same for all main bearings.

E. Aluminum engine blocks will not be permitted.

20C - 5.5.2 Internal Changes

A. Boring and honing of the cylinders will be permitted. Cylinder bores must remain round.

B. Internal polishing of the engine block will be permitted.

C. Relocation of the camshaft will not be permitted.

20C - 5.5.3 Pistons / Rods

A. Only round aluminum pistons will be permitted.

B. All pistons must be configured with two (2) separate compression piston ring grooves located near the top of the piston and one (1) oil ring groove located below the compression ring grooves. A piston compression ring must be used in each compression ring groove and one (1) oil ring assembly must be used in the oil ring groove.

C. Only solid magnetic steel connecting rods will be permitted.

D. Only round piston pin holes with a fixed location in the piston and the connecting rods will be permitted.

E. Titanium and stainless steel connecting rods will not be permitted.

F. Only two-piece insert style connecting rod bearing will be permitted. Roller bearings will not be permitted.

20C - 5.5.4 Oil Pans / Oil Coolers

The oil pans and oil coolers must be acceptable to ARCA Officials and meet the following minimum requirements:

A. Oil pans must be made of magnetic steel and may be a maximum of 10 inches wide, measured five (5) inches maximum each side from the center of the crankshaft. The side walls must not angle outward past vertical. The exterior of the oil pan must be of welded one-piece construction. Spacers, other than sealing gaskets, will not be permitted between the oil pan side rails and the engine block

surface.

B. Segmented oil pans and/or crankcases will not be permitted. The oil pan and crankcase area must remain open. Additions of materials to the engine block, engine block components, and/or the oil pan to separate the crankcase area from front to rear will not be permitted.

C. A maximum of four (4) oil pump scavenging pick-ups will be permitted into the oil pan. The scavenging pick-ups must draw oil from the inside bottom of the oil pan.

D. Sealed windage trays will not be permitted.

E. A single baffle (windage screen) may be used inside the oil pan providing it is constructed from wire mesh or louvered metal. The baffle (windage screen) must be installed in a straight line from the front to the rear of the oil pan. The baffle (windage screen) must attach to the upper sidewall and to the bottom of the oil pan on the same side. Clearance between the baffle (windage screen) and the engine main bearing caps must not be less than 1-1/2 inches when viewed horizontally. Directional baffles in the bottom of the oil pan must not be higher than one (1) inch.

F. Engine oil coolers must be an oil to air or an oil to water heat exchanger. All engine oil coolers must be located between the front sub-frame rails, in or behind the radiator and forward of the engine. When an oil to air heat exchanger is used, it must have a minimum of nine (9) fins per inch on the cooling tubes. All oil coolers and their installation must be acceptable to ARCA Officials.

20C - 5.6 Cylinder Head

A. All modifications must be submitted to ARCA before any proposed modification will be eligible for approval. Approved manufacturers identification and part numbers in the form of cast-in part numbers must remain unaltered on the cylinder heads being used in competition.

B. The following cylinder heads are only approved for use with the ARCA Built engine:

<u>MANUFACTURER</u>	<u>PART NUMBER</u>	<u>CASTING NUMBER</u>
Ford (dated 9/9/91 or later)	E3ZM6049C3	E3ZM6049C3
	E3ZM6049C3L	E3ZM6049C3
General Motors		
18 Degree	10134364	10134363
18 Degree	24502580	10134363

C. The following cylinder heads are only approved for use with the ARCA Legacy engine:

<u>MANUFACTURER</u>		
Dodge	Ford	General Motors
P7	C3	SB2
	D3	

ARCA Officials may use a cylinder head provided by the respective manufacturer as a guide in determining whether a Competitor's cylinder head conforms to the specifications of the Rule Book.

20C - 5.6.1 Eligibility

To be eligible, the approved cylinder heads must be acceptable to ARCA Officials and meet the following requirements:

1. When the ARCA-approved Built engine is used the valve angle and valve location must remain as approved.

Spacing between the valves measured center to center is:

<u>MANUFACTURER</u>	<u>VALVE ANGLE</u>	<u>SPACING</u>
Ford	Intake 7-1/2 degrees	1.900 inches
	Exhaust 8 degrees	
General Motors	18 degrees	1.935 inches

Valves must remain in the approved location in relation to the cylinder bore centerline.

2. The top of the intake ports must remain in the approved location measured on the inside top of the port.
3. The vertical centerline of the intake port entrance must be straight and perpendicular to the cylinder head gasket surface. The vertical centerline of the intake port must remain in the approved location. The horizontal centerline of the intake port must be straight and parallel to the cylinder head gasket surface.
4. The vertical and horizontal centerlines of the exhaust port exit must remain in the approved location. The vertical and horizontal centerlines must be straight lines. The horizontal centerline must be parallel to, and the vertical centerline must be perpendicular to, the cylinder head gasket surface. If material is removed from the top or side of the exhaust port, the same amount must be

removed from the bottom or opposite side of the port.

5. The rocker arm fastener bolt holes must remain in the approved location.
6. Only stainless steel or titanium valves will be permitted. Exotic materials will not be permitted.
7. Only magnetic steel valve springs will be permitted.
8. Only two (2) valves per cylinder will be permitted.
9. There are no restrictions on the valve size.
10. Internal polishing and porting will be permitted.
11. Spark plug holes must remain in the approved location.
12. Angle cutting of the cylinder head to the engine block mating surface will not be permitted.
13. Milling of the cylinder heads will be permitted, but not to exceed 0.175 inch.
14. "O" rings will not be permitted for sealing the cylinder head to the engine block.

20C - 5.6.2 External Changes

A. External modifications for the approved cylinder heads will be permitted providing the external dimensions of the cylinder head have not been changed in respect to original height (plus 0.100 inch for Ford, plus 0.080 inch for General Motors or minus 0.175 inch for all engines), original length, and original width as compared to the cylinder heads described in sub-section 20C-5.6.

B. External modifications for the Ford cylinder head, part number E3ZM6049C3L and General Motors 18 degree cylinder head, part number 24502580 will be limited to milling of the head not to exceed 0.175 inch.

C. Painting or coating of the cylinder heads will not be permitted.

20C - 5.6.3 Internal Changes

Except as provided below, internal polishing and porting will be permitted. The addition of foreign material (i.e. epoxy, plastics, etc.) to the production casting will not be permitted. The original internal shape and configuration of the port must not be notched, grooved, channeled or ridged in any way. After porting and/or polishing the intake port walls, port roof and port floor from the intake manifold mating surface to the centerline of the intake valve, air can flow over one (1) surface each. When the manufacturer has cast a valve guide support into the roof of the intake port the valve guide support must be blended into the roof of the intake port, eliminating all sharp edges. The maximum port floor height, maximum port roof height, port centerline, and spark plug locations must conform to the approved ARCA template.

20C - 5.7 Crankshaft / Harmonic Balancer

20C - 5.7.1 Crankshaft

A. Only one-piece magnetic steel crankshafts will be permitted.

B. Aftermarket crankshafts must have the same design as an OEM type crankshaft for the approved engine and must be acceptable to ARCA Officials.

C. Only two-piece insert style crankshaft main bearings will be permitted. Roller bearings will not be permitted.

D. Crankshafts may be lightened and balanced. A solid material must be used to balance crankshafts.

20C - 5.7.2 Harmonic Balancers

A. Harmonic balancers must be used and must be used as manufactured. Only SFI 18.1-approved magnetic steel harmonic balancers and balancer hubs, acceptable to ARCA, will be permitted.

B. Unless otherwise authorized by ARCA, electronic switching devices, sensors or magnets will not be permitted on or near the harmonic balancer, crankshaft, camshaft or flywheel.

20C - 5.8 Camshaft / Valve Lifters / Rocker Arms

20C - 5.8.1 Camshaft

A. Any magnetic steel roller or flat tappet lifter camshaft will be permitted. The maximum camshaft bearing journal size must not be more than 2.362 inches (60mm).

B. Only standard production design timing chains and belt drives will be permitted for operating the camshaft on all engines. Camshaft timing must be fixed, variable timing devices will not be permitted. All camshaft timing drive systems must be acceptable to ARCA Officials.

C. Camshafts must be driven in the same direction of rotation as the ARCA-approved standard production engine crankshaft. The camshaft must maintain the same firing order as the ARCA-approved production engine.

The approved firing orders using approved cylinder identification are as follows:

Dodge	1-8-4-3-6-5-7-2
Ford	1-3-7-2-6-5-4-8
General Motors	1-8-4-3-6-5-7-2

D. The manufacturer's cylinder identification sequence is as follows:

<u>Dodge</u> (Front)	<u>Ford</u> (Front)	<u>General Motors</u> (Front)
1 2	5 1	1 2
3 4	6 2	3 4
5 6	7 3	5 6
7 8	8 4	7 8

20C - 5.8.2 Valve Lifters

A. Valve actuation must be limited to one (1) lifter, one (1) push rod and one (1) rocker arm per valve. All valve actuation systems must be acceptable to ARCA Officials.

B. Only solid magnetic steel flat tappet straight barrel and steel roller lifters will be permitted.

C. The lifter diameter must not exceed a maximum of 0.875 inch for flat tappet lifters and 0.940 inch for roller lifters.

D. Any type of mechanical assistance exerting a force to assist in closing the valve, commonly known as rev-kits, will be permitted.

E. Only magnetic steel one-piece, push rod assemblies without any moving parts, will be permitted.

20C - 5.8.3 Rocker Arms / Valve Covers

A. Only steel or aluminum rocker arms, one (1) per valve that are acceptable to ARCA Officials may be used.

B. Valve covers must be made of steel or aluminum. Magnesium and other exotic materials will not be permitted.

20C - 5.9 Intake Manifold

A. The approved manufacturers identification in the form of cast-in part numbers must remain unaltered on the intake manifold.

B. The intake manifold must conform to the ARCA-approved templates, gauges, scales and other measuring devices.

C. ARCA Officials may use an intake manifold provided by the respective manufacturer as a guide in determining whether a Competitor's intake manifold conforms to the specifications of the Rule Book.

D. Only open plenum intake manifolds will be permitted. The plenum opening must not be smaller than a minimum size of 3-5/8 inches in width by 3-9/16 inches in length. The maximum plenum opening size must not be larger than 3-3/4 inches in width by 3-11/16 inches in length. The plenum opening must have radiused corners that maintain the shape and configuration of an open four (4) barrel carburetor gasket.

E. The inside floor of the plenum and the carburetor mounting flange must remain in the approved location.

F. The plenum will be defined as the area inside the opening of the intake manifold from the plenum opening at the carburetor mounting flange down to the floor of the plenum. Included in the plenum area will be where the runner walls attach at the top and bottom in the plenum. The intake manifold runners will be defined as starting at the point of attachment both at the top and the bottom in the plenum area of the intake manifold.

G. The intake runners must maintain the same length as compared to the approved intake manifold with the same part number.

H. The centerline of the intake ports, as seen from above, must remain in the approved location.

I. Each ARCA-approved built engine will be permitted a maximum of four (4) approved intake manifolds. New approvals must be preceded by deleting a currently approved manifold. The following intake manifolds are approved for use in competition:

MANUFACTURER

Ford

General Motors

18 Degree:

PART NUMBER

Ford M-9424-A351

Ford M-9424-X351

Edelbrock 2961

Edelbrock 2991

GM 24502481

GM 24502653 Spider

Edelbrock 2955 Spider

Edelbrock 2958

When the ARCA-approved Legacy engine is used the intake manifold must be acceptable to ARCA Officials and must conform to all intake manifold gauges.

J. Modifications Permitted:

1. Polishing in the plenum area is permitted only to “clean up” imperfections in the castings in a manner acceptable to ARCA Officials.
2. Polishing of ports in the intake manifold will be permitted.

K. Modifications Not Permitted:

1. Added air directional devices will not be permitted inside the intake manifold.
2. The length of the intake manifold runners must not be changed and remain as manufactured.
3. Epoxy or fillers will not be permitted on the plenum floor or on the walls of the plenum.
4. Air holes will not be permitted to be opened in the intake manifold.
5. External modifications to the intake manifold will not be permitted unless approved by the Series Director.
6. Painting and/or coating of the intake manifold will not be permitted.
7. Drilling or tapping of the intake manifold plenum or intake runners will not be permitted unless approved by the Series Director.

L. Spacers between the engine block and the intake manifold will not be permitted.

M. Spacers between the intake manifold and the cylinder heads will not be permitted.

N. The intake manifold must have a minimum of 1/4 inch of surface on all sides to seal the intake manifold to the cylinder head.

O. The carburetor mounting studs must be solid and remain in the approved location and maintain a stud size of 5/16 inch diameter.

P. Any spacer added between the carburetor (per sub-section 20C-5.10.2) and the intake manifold must be mounted using the approved 5/16 inch diameter, solid carburetor mounting studs and must not be welded to the intake manifold.

Q. The intake manifold and the valley tray material must be aluminum. Magnesium and other exotic materials will not be permitted.

R. The intake manifold ports must be completely sealed to the cylinder head ports at all times. Intake manifold sealing must be done by using one (1) approved paper-type intake manifold gasket per side. Metal shim type or metal impregnated intake manifold gaskets will not be permitted. The as manufactured thickness of approved intake manifold gaskets must not be less than 0.060 inch and must not be more than 0.125 inch per side. Intake manifold gaskets must be secured to either sealing surface (intake manifold or cylinder head) with an approved adhesive. At ARCA's discretion the intake manifold and cylinder heads may be leak tested to ensure proper sealing at any time during the Event.

20C - 5.10 Carburetor/Throttle Body

ARCA Officials may use a carburetor/throttle body provided by the respective manufacturer as a guide in determining whether a Competitor's carburetor/throttle body conforms to the specifications of the Rule Book.

20C - 5.10.1 Eligibility

A. The following carburetors/throttle bodies are eligible for use:

1. The Holley 4150HP Series, list number 80507 (390 CFM), four (4) barrel carburetor with a maximum venturi size of 1-1/16 inches and a maximum throttle bore size of 1-7/16 inches is the only carburetor approved for use on all ARCA-approved Built engines (See F. below for rework guidelines).
2. The Holley 4150HP Series, list numbers 80509 and 80509-3 (830 CFM), four (4) barrel carburetors are the only carburetors approved for the Robert Yates Racing Engines “Spec Engine”. The carburetor must remain as supplied without any modifications (refer to sub-section 20C-4.1C).
3. The Holley 4150 Series, casting numbers 6R-5533B or 6R-7880B (830 CFM), four (4) barrel with a venturi size of 1-9/16 inch and a throttle bore size of 1-11/16 inch is the only carburetor approved for use on all ARCA-approved Legacy engines (See G. below for rework guidelines).

B. The Holley throttle body part #112-601 and Ilmor throttle body part #BX4i are the only approved throttle bodies for use on the ARCA Ilmor engines. The throttle body and part number must remain as manufactured without any modifications. The throttle plates must open simultaneously as manufactured and equally. All mechanisms must work mechanically.

C. Only Holley replacement or service parts can be used in any carburetor rework.

D. Carburetors and/or carburetor components machined from billet materials will not be permitted.

E. All carburetor modifications must be acceptable to ARCA Officials.

F. Holley 4150HP Series, list number 80507 (390 CFM) rework guidelines are as follows:

1. Carburetor Main Body

The only carburetor main body that will be permitted will be the Holley main body with casting number 6R-7879B. The Holley casting numbers must remain legible on the top of the main body. Main bodies must remain as manufactured. Machining, reshaping, grinding, polishing, or drilling

holes will not be permitted. The addition of material(s) such as but not limited to, epoxies, sleeves, inserts or tubes will not be permitted to the carburetor main body.

2. Carburetor Boosters

One (1), one-piece singular discharge booster per venturi must be used. The type of booster must not be changed. The Holley booster part number 45R-107-1, with the casting number 45R-107 and part number 45R-312R, with the casting number 45R-312 are the only boosters that will be permitted. The Holley casting numbers must remain legible on the top of all booster stems. Size and shape must not be altered. Height and location of the boosters must remain as manufactured. All boosters must maintain a minimum outside diameter of 0.616 inch. The maximum inside diameter of the booster stem passage must not exceed 0.144 inch. The addition of material will not be permitted to the boosters. A bonding agent (epoxy) may be used to assist in adhering the carburetor booster to the carburetor main body, but it must not extend past the carburetor main body booster mounting hole into the carburetor venturis. Each carburetor booster must be secured by a steel wire not less than 0.025 inch in diameter. The wire must be installed in such a manner that in the case of a carburetor booster failure, the carburetor booster should remain suspended in the carburetor without any interference to the operation of the throttle shaft and the throttle plates (butterflies). A minimal size hole, acceptable to ARCA Officials, must be drilled through the top of the booster barrel, inboard of the booster attaching stem. The 0.025 inch steel wire must loop through the hole in the booster barrel and then be tied to the respective float bowl vent tube. As an alternative to drilling a hole in the booster, the 0.025 inch steel wire must pass through the booster barrel from top to bottom and then be tied to the respective float bowl vent tube.

3. Carburetor Venturis

The venturi is defined as a constricted throat in the main body air passage. The location of the venturi must remain as produced by the manufacturer. The venturis must not be raised or lowered in the body of the carburetor. The venturis must maintain a circular (round) cross section. The maximum diameter of the venturis must not exceed 1.064 inches. Altering or reshaping of the venturi in any manner will not be permitted.

4. Carburetor Throttle Body (base plate)

The only carburetor throttle bodies permitted will be the Holley throttle bodies with casting numbers 12R-6236B, 12R-11524B or 12R-11524M. The Holley casting number must remain legible on the left secondary "ear" of the carburetor throttle body casting number 12R-6236B, and on the right secondary "ear" of the carburetor throttle body casting number 12R-11524B or 12R-11524M. The carburetor throttle body must be used as provided by the manufacturer. The positioning of the throttle bores in the carburetor throttle body must be the same as provided by the manufacturer. The throttle bores must be completely round. The throttle bores must not be larger than 1.438 inches. The throttle bores must be straight without taper from top to bottom. The throttle bores must remain perpendicular to the top and bottom of the carburetor throttle body. The carburetor throttle body must not be altered in shape or size.

5. Throttle Plates (butterflies)

The throttle plates (butterflies) must be magnetic steel and must not be thinned or tapered. The type of screw used to retain the throttle plates (butterflies) to the throttle shafts must be pan head type either straight slotted, phillips head or allen type head. Idle holes may be drilled in the throttle plates (butterflies). The throttle plates (butterflies) must be mounted to the throttle shaft in the approved location.

6. Throttle Shafts

Holley magnetic steel throttle shafts must be used. Shafts must remain standard production size and must not be thinned or cut in any manner. Throttle shaft rotation must be in the same direction as produced by the manufacturer. The combined thickness of the throttle shaft and the throttle plate (butterflies) must not be less than 0.197 inch. Throttle shaft seals that prevent air leakage must be used on all throttle shafts where the shafts exit the carburetor throttle body. The primary and secondary throttle shafts must each have an independent travel stop to prevent the throttle plates (butterflies) from opening beyond vertical.

7. Carburetor Metering Blocks

Only Holley metering blocks will be permitted. Surfacing of the metering blocks for improved gasket seal will be permitted. A bonding agent (epoxy) may be used to assist in adhering the emulsion tube plugs to the carburetor metering blocks, if needed to help prevent fuel leakage only.

8. Carburetor Floats

Carburetor floats must be a Holley replacement or service part acceptable to ARCA Officials.

9. Alterations that, in the judgment of ARCA Officials, were made to allow additional air to be picked up below the opening of the venturi, such as but not limited to, altered gaskets, throttle bodies, drilling or machining holes into the carburetor will not be permitted.

10. External modifications and/or alterations to the carburetor will not be permitted.

G. Holley 4150 Series, casting numbers 6R-5533B or 6R-7880B (830 CFM) rework guidelines are as follows:

1. Carburetor Main Body

The only carburetor main bodies that will be permitted will be the Holley main bodies with casting numbers 6R-5533B or 6R-7880B. The Holley casting numbers must remain legible on the top of the main body. Carburetor bore cannot have any steps, radiuses or compound angles. The main body must have a smooth transition from the venturi to the carburetor base plate. Cross vent air tubes must be removable.

2. Carburetor Boosters

The boosters must remain stock appearing. The booster casting number must remain visible. The following boosters are approved for competition:

Booster Description	Casting ID #	Holley Part #
Down Leg Standard	45R-168	45R-168BR
Down Leg Standard	45R-168	45R-206-1
Down Leg Stepped	45R-168	45R-296
Down Leg Large Shank	45R-131	45R-131
Straight Leg	45R-312	45R-312R
Straight Leg	45R-107	45R-107-1
	45R-111	
Straight Leg/Small Skirt	45R-149	45R-149R
Standard Annular	None	45R-299A
Ford Truck	None	45R-238A

Each carburetor booster must be secured by a steel wire not less than 0.025 inch in diameter. The wire must be installed in such a manner that in the case of a carburetor booster failure, the carburetor booster should remain suspended in the carburetor without any interference to the operation of the throttle shaft and the throttle plates (butterflies). A minimal size hole, acceptable to ARCA Officials, must be drilled through the top of the booster barrel, inboard of the booster attaching stem. The 0.025 inch steel wire must loop through the hole in the booster barrel and then be tied to the respective float bowl vent tube. As an alternative to drilling a hole in the booster, the 0.025 inch steel wire must pass through the booster barrel from top to bottom and then be tied to the respective float bowl vent tube.

3. Carburetor Throttle Body (base plate)

The carburetor base plate must have a throttle bore size of 1-11/16 inch and must remain in the stock location without any modifications. Nothing may be added to the base of the carburetor to extend down into the intake.

4. Throttle Plates (butterflies)

The throttle plates must remain flat and in the stock location. Idle holes may be drilled in the throttle plates. The throttle plates must open simultaneously as manufactured and equally. All mechanisms must work mechanically.

5. Alterations that, in the judgment of ARCA Officials, were made to allow additional air to be picked up below the opening of the venturi, such as but not limited to, altered gaskets, throttle bodies, drilling or machining holes into the carburetor will not be permitted.

20C - 5.10.2 Carburetor / Throttle Body Spacer / Gaskets

A. A one-piece, solid, aluminum carburetor spacer, up to a maximum one (1) inch in thickness, may be installed between the intake manifold and the carburetor on all ARCA-approved Built engines. An open or four (4) hole spacer may be used. The spacer opening must be perpendicular to the base of the carburetor with no taper or bevel.

B. A one-piece, solid, open hole aluminum carburetor spacer, up to a maximum one (1) inch in thickness, may be installed on the intake manifold on all ARCA-approved Legacy engines. The spacer opening must not be less than 3-9/16 inches in length and 3-5/8 inches in width and have radiused corners that maintain the shape of the ARCA intake manifold gauge. The spacer opening must be perpendicular to the base of the carburetor with no taper or bevel.

C. The carburetor spacer used on the Robert Yates Racing Engines "Spec Engine" must remain as supplied by the approved supplier.

D. The spacer cannot not be welded to the intake manifold.

E. Only non-metallic gaskets (1 per side), with a maximum thickness of 0.065 inch, will be permitted.

F. The gasket surfaces of the spacer must conform to the shape of the carburetor/

throttle body base plate. Gaskets can only be altered to match the carburetor base plate openings.

20C - 5.10.3 Carburetor / Throttle Body Restrictor

A. A carburetor/throttle body restrictor must be used when required by ARCA.

B. For Events where a restrictor plate is required:

1. A restrictor plate, a one (1) inch thick four-hole spacer and necessary sealing gaskets will be issued by ARCA for competition.
2. Spacer(s) between the restrictor plate and the intake manifold or above the ARCA-issued four-hole spacer will not be permitted.

For Events where a tapered bore spacer is required:

1. Tapered bore spacers and necessary sealing gaskets will be issued by ARCA for competition.
2. Spacer(s) between the tapered bore spacer and the intake manifold or above the tapered bore spacer will not be permitted.

C. When the approved "Spec Engine" is used taller carburetor studs will be required to allow for proper installation of the carburetor and carburetor restrictor.

D. Competitors must use the restrictor plate or tapered bored spacer as issued by ARCA Officials. A final restrictor plate or tapered bored spacer size will be determined after the completion of the final practice prior to the Race. Any attempts to, and/or actions that result in, pulling air from sources other than normal approved methods through the air filter and carburetor/throttle body venturis, such as, but not limited to, drilling of holes or altering of restrictor plates, tapered bore spacers or gaskets will not be permitted.

20C - 5.10.4 Carburetor/Throttle Body Fuel Filter

The location and size of the fuel filter(s) must be acceptable to ARCA Officials (refer to sub-section 20C-16.5.1H).

20C - 5.11 Forced Air Induction

Superchargers or turbochargers will not be permitted.

20C - 5.12 Air Filter / Air Intake

The air filter housing, including the filter, must be installed at all times during practice or competition. Performance enhancing additives or chemicals will not be permitted in the air filter housing, air filter, or the air intake area.

20C - 5.12.1 Air Filter / Air Filter Housing

A. Only a round dry type, unaltered paper or dry type gauze air filter element maintaining a minimum of 12 inches and a maximum of 17 inches outside diameter will be permitted. The air filter element must maintain a minimum of 1-1/2 inches and a maximum four (4) inches in height. The air filter element must maintain a consistent height when measured anywhere around the circumference of the air filter element. All air filter elements must remain as manufactured. All air must be filtered through the element.

B. Only a round ARCA-approved composite or metal air filter housing will be permitted. The top and bottom of the air filter housing must be solid and must be the same diameter. The top and the floor of the air filter housing from the air filter element to the outside edge of the air filter must remain parallel to the top and bottom of the air filter element. A maximum of a one (1) inch lip will be permitted from the air filter element to the outside edge of the air filter housing top and bottom. The air filter housing must be centered on the carburetor and seated on the air filter housing gasket ring. The air filter housing carburetor/throttle body mounting ring must have one (1) round hole. Except for one (1), vertical vane, centered in the air filter housing, front to rear, tubes, funnels or any other devices that may control the flow of air will not be permitted inside of the air filter, air filter housing or between the air filter housing and the carburetor/throttle body. Two (2) 1/4 inch diameter drain holes must be drilled in the bottom of the air filter housing at the lowest point. Additional holes will not be permitted.

C. Tape may only be used in a manner acceptable to ARCA Officials.

20C - 5.12.2 Air Intake / Cowl

A. Only cowl air induction (cold air box) will be permitted. The cowl opening must be connected to the air filter housing by extending the cowl air deflector to the sides of the air filter housing by the straightest possible line to the outer circumference of the housing. Similarly, the floor of the cowl air deflector must be attached flush to the bottom of the air filter housing with only one smooth bend or single radius allowed from the windshield to the air filter housing. The floor of the cowl air deflector must not be below the floor of the air filter housing. Steps, ridges, vanes, venturis, air deflectors or restrictions will not be permitted in this area.

B. The cowl-opening panel must remain as manufactured.

C. The maximum cowl opening allowed is 20 inches long by 2-1/2 inches wide. The front of the cowl panel must seal to the back of the hood when the hood is closed.

20C - 6 ENGINE / VEHICLE ELECTRICAL SYSTEM

All engine/vehicle electrical system components must be approved by ARCA. Each such part may thereafter be used until ARCA determines that such part is no longer eligible.

20C - 6.1 Ignition System

- A. Magnetos or computerized systems will not be permitted.
- B. Crank trigger ignition systems will not be permitted on currently approved built engines.
- C. Adjustable timing controls will not be permitted.
- D. Retard or ignition delay devices will not be permitted.
- E. The ignition system wiring must not contain any open wires or terminals. Unused ignition amplifier box wires must be terminated and/or sealed to prevent connection in a manner acceptable to ARCA Officials.
- F. Each vehicle must have primary ignition system components and may have optional backup ignition system components. The backup ignition system components must be disconnected from the primary system components using primary/backup switch(s). The ignition systems must consist of an ignition amplifier box, coil, distributor pickup and optional rev limiter (internal/external).
- G. The ARCA Ilmor engines must use the Holley Engine Control Unit (ECU) Part #554-132. The Engine Control Unit (ECU) must be mounted as described in H. and I. below.
- H. Ignition system components including, but not limited to, the Engine Control Unit (ECU), ignition amplifier boxes, coils and external rev limiter must be mounted to a removable ignition system mounting plate, as described in J. below.
- I. A removable ignition system mounting plate, acceptable to ARCA Officials, must be attached to the right side dash panel and located to the right side of the center windshield bar (#4A) with a minimum of four (4), minimum 1/4 inch diameter bolts. The removable ignition system mounting plate must be metal. The components must be visible for ease of inspection through the windshield and be wired such that the plate can be easily removed for inspection purposes.
- J. ARCA Officials may at their discretion inspect, test and/or destructively test ignition system components including ignition amplifier boxes, tachometers, distributors, etc.
- K. ARCA Officials may use approved ignition system components provided by the respective manufacturer as a guide in determining whether a Competitor's ignition system components conform to the approved components.

20C - 6.1.1 Ignition System Wiring

- A. All ignition system wiring, including wiring to the Engine Control Unit (ECU), ignition amplifier box, distributor and/or any gauges must be acceptable to ARCA Officials.
- B. When the ARCA Ilmor engine is used, the Holley wiring chassis harness Part #558-120 must be used.
- C. With the exception of the distributor pickup wire pairs and coil wire pairs, each ignition system wire must remain separate and inaccessible during competition.
- D. Ignition system wires must be continuous from the start connector to the end connector. Splices, bare and punctured wires will not be permitted in the ignition system.
- E. All connectors must allow for the application of an ARCA seal.
- F. The distributor pickup signal must be carried by a shielded wire pair with one (1) shielded ground wire. The wire pair may be twisted within the shield. The shielded ground wire must be located and grounded at the end nearest the ignition amplifier box.
- G. Only the distributor pickup wire pairs can be contained within a shielding wrap with one (1) wire pair per shielding wrap. Tape, heat shrink wrap, and/or banded wire looms will not be permitted in the ignition system wiring.
- H. A dedicated single ground stud must be located on, or as close as possible to, the dash panel bar (#8). All ignition system components must be grounded at this stud. Accessory components must not be connected to this stud. A ground wire may be run from this stud to the battery ground or main ground stud.
- I. Additional connectors may be permitted at the ARCA Officials discretion to facilitate removal for inspection purposes.
- J. The use of tracer wire color schemes is acceptable to specify backup components.
- K. Accessory component wiring, including power and ground wires, must remain completely separate from the ignition system wiring and away from ignition system components. Ignition system components must draw power from the battery side of the starter solenoid. When the starter solenoid is an integral part of the starter assembly, ignition system components must draw power from a single stud terminal block located visibly on the bottom of the dash panel bar (#8), near the removable ignition system mounting panel. Power must be supplied to the single stud terminal from the master power switch. Accessory components and switches will not be permitted to draw power from the ignition system wiring at any point.

20C - 6.1.2 Ignition Amplifier Box

A. Ignition amplifier boxes and rev limiters that are analog only, which do not contain programmable, computerized, or memory circuits, will be permitted.

B. Rev limiting devices acceptable to ARCA Officials may be required and must be attached and wired to the ignition amplifier box(s) in a visible manner. Terminals and pin connections designed for the rev limiter connection must have the ability to apply an ARCA seal. Rev limiter chips must have the ability to apply an ARCA seal.

C. The ignition amplifier box(s) may have either an internal rev limiter or be connected to an external rev limiter.

D. Each ignition amplifier box is allowed six (6) ignition wires, two (2) power leads and either a rev limiter pin connection or approved rev limiter connection terminal. If originally equipped with a single white points trigger wire and the white points trigger wire is not used with an interrupt switch/system or required by the distributor, the white points trigger must be terminated and sealed to prevent connection in a manner acceptable to ARCA Officials. If a remote interface control box is connected to the white points trigger wire, this wire must be encased in a grounded shield.

E. The ignition amplifier box must use a connector of the Packard Electric type (MSD part #8170) or the Deutsch Connector type (MSD part #8180) to facilitate testing of the ignition components during inspection. The wiring sequence must be the same as the General Motors or Ford ignition amplifier boxes. The wire color, gage, and pin assignment must follow the table below:

	<u>Pin</u>	<u>Description</u>	<u>Color</u>	<u>Gage</u>
MSD	Deutsch			
A	5	Power	Red	16-18
B	2	Tachometer Signal	Green or Brown	16-18
C	6	Coil (-)	Black	16-18
D	1	Coil (+)	Orange	16-18
E	3	Pickup (-)	Green	16-18
F	4	Pickup (+)	Violet	16-18

F. The ground negative (-) lead wire must be a continuous single black minimum 12 gage wire and the positive (+) power lead must be a continuous single red minimum 12 gage wire.

G. Modifications to ignition amplifier boxes will not be permitted.

20C - 6.1.3 Distributor

A. The distributor must mount in the approved location and maintain the same firing order as the approved factory produced engine for the make and model engine, as described in sub-section 20C-5.8.1C.

B. Only two (2) ignition pick-ups of the magnetic optical or Hall-effect type will be permitted in the distributor.

C. The distributor must have a single connection to the coil selector, two (2) shielded distributor pickup wire pairs connecting the distributor pickup to the ignition amplifier box, eight (8) spark plug wire connections, and may have two (2) power wires for distributor pickups that require a power source. Power leads must never be contained in a common connector with the signal wires.

D. The positive (+) pickup wire must be a single continuous 16-18 gage violet wire and the negative (-) pickup wire must be a single continuous 16-18 gage green wire. These two (2) wires must be a pair encased by a grounded shield. The ground must run to the dedicated ignition ground stud.

E. A distributor which uses a remotely mounted interface control box(s), must have the interface control box mounted on the removable ignition system mounting plate. Wiring from the distributor interface control box and the signal wire from the interface control box to the ignition amplifier must be encased in a grounded shield. The interface control box must be used as produced by the manufacturer with no modifications and may be sealed by ARCA Officials. The interface control box must be accessible and removable for inspection purposes.

F. When not used with the remote interface control box, the optional power wires must each be a single continuous 16-18 gage red wire connected to the primary/backup switch. The distributor end of the wire must have a connector of the Packard Electric type (MSD part #8174), or an ARCA-approved equivalent, to facilitate testing of the ignition components during inspection.

20C - 6.1.4 Coils

A. The positive (+) coil wire must be a single continuous 16-18 gage orange wire and the negative (-) coil wire must be a single continuous 16-18 gage black wire. The coil wire pair may be twisted.

B. The coil wires may use a connector of the Packard Electric type (MSD part #8173) or ARCA-approved equivalent. If used, Pin "A" must be the negative (-) pickup wire and Pin "B" must be the positive (+) wire.

C. At least six (6) inches of the secondary spark wire from the coil selector to the distributor must remain easily accessible on the removable ignition system

mounting plate for RPM sensor application.

D. A coil secondary spark wire selector will be permitted.

E. A firewall feed through connector may be used between the coil and distributor.

20C - 6.1.5 Tachometers

A. Tachometers, if used, must be mounted to either the steering column or the dash gauge panel. The mounting must be acceptable to ARCA Officials. In all cases, tachometer wiring must be as visible as possible, and easily accessible for inspection.

B. Tachometers should have a maximum of three (3) wires connected to the ignition system allowing for a ground, power, and a tachometer signal.

C. The tachometer must have a connector of the Packard Electric type (MSD part #8172), or ARCA-approved equivalent, to facilitate testing during inspection. The tachometer connector must be located on or at the removable ignition system mounting plate. The wire color, gage, and pin assignment must follow the table below.

<u>Pin</u>	<u>Description</u>	<u>Color</u>	<u>Gage</u>
A	Ground	Black	16-18
B	Power	Red	16-18
C	Tachometer Signal	Green or Brown	16-18

D. The tachometer signal wire must be run from the tachometer as a single continuous green or brown 16-18 gage wire to connect the primary and backup ignition amplifier boxes to the tachometer through blocking diode(s).

E. The tachometer power wire must be connected to the battery side of the starter solenoid.

F. If an illuminated tachometer is used, the light power and ground wires must connect into the tachometer power and ground between the tachometer and the tachometer connector.

G. Tachometers with integral shift lights, or pit road speed lights will be permitted.

H. If an external shift light or pit road speed light is used, its signal input must come from the primary and/or backup ignition amplifier boxes and not as an output from the tachometer.

20C - 6.1.6 Interrupt Switch

A. An auxiliary on/off button that will shut off the ignition system must be mounted on the steering wheel within reach of the driver's thumb when the hands are in the normal driving position. The auxiliary switch must shut off the engine immediately when depressed and the engine must not restart until the button is depressed again.

B. An ARCA-approved ignition interrupt system which contains a manifold vacuum switch and a brake line pressure switch (and may include a brake pedal position switch) may be used at the crew chief's option, in conjunction with or to replace the auxiliary on/off button on the steering wheel.

C. An ARCA-approved throttle override system (Tigor Switch) mounted in the throttle linkage may be used and is highly recommended. If the throttle override system is used it must be used in conjunction with the auxiliary on/off button mounted on the steering wheel or an ARCA-approved ignition interrupt system which contains a manifold vacuum switch and a brake line pressure switch (and may include a brake pedal position switch).

D. The button/interrupter should be mounted inline of the red 16-18 gage power between the main ignition switch and the primary/backup switch. When the button/interrupter is engaged the ignition amplifier box must automatically shut off. If the ignition amplifier box is originally equipped with a single, white points trigger wire, this wire may be used with an interrupt switch/system.

E. The button/interrupter must use a connector of the Packard Electric type (MSD part #8173), or ARCA-approved equivalent, to facilitate testing of the ignition system during inspection.

F. Unless otherwise authorized by the Series Director, switches and/or any device other than those described above that are designed to interrupt the operation of the engine will not be permitted.

20C - 6.1.7 Main Ignition Switch

The main ignition switch must be an on/off toggle type and be located next to the starter switch in the main switch panel. The switch must connect power to the input of the interrupter device.

20C - 6.1.8 Primary / Backup Switch

A single switch may be used to select the primary or backup ignition system and it must be mounted on the dash panel.

20C - 6.2 Spark Plugs

Any make or brand of spark plugs may be used except when the ARCA Ilmor engine is used. All spark plugs must thread into the cylinder heads using only M14 x 1.25 threads.

20C - 6.3 Alternator

A single alternator system with an internal voltage regulator and one (1) output wire must be used. External voltage regulators will not be permitted. The alternator must be mounted on the front of the engine with the center higher than the center of the water pump. Only standard production V-type or flat type V-ribbed alternator drive belts will be permitted. Cog type belts will not be permitted.

20C - 6.4 Starter

The self-starter must be in working order and in the approved location. Gear reduction starters acceptable to ARCA Officials will be permitted. If the ARCA Ilmor engine is used the starter must be used as supplied by the engine supplier without modifications. Competitors will be permitted to remove and install the starter. The starter may be rebuilt by either the engine supplier or by a third-party service provider.

20C - 6.5 Battery

A. Only ARCA-approved batteries with a maximum nominal voltage of 12 volts will be permitted.

B. The battery(s) must be located in a battery box inside the left or right rear quarter panel in front of the left or right rear tire. Any battery(s) installed during the Race must be installed in the battery box.

20C - 6.6 Electrical Switch Locations

A. A labeled on/off rotary-type master switch, with "on" being in the clockwise direction, must be located at or on the front of the dash panel near the longitudinal centerline of the vehicle while remaining within the reach of the driver, when secured by the seat belts in the seat. The switch must be wired to the battery cable in a manner that will disconnect all electrical power in the vehicle.

B. All ignition, starter and accessory electrical switches must be located on the front of the dash panel. Within the switch panel, accessory switches must be located to the right or below the main ignition switch. All electrical switches must be labeled.

C. Accessory wiring must remain separated from the ignition wiring system.

20C - 6.7 Accessories

A. Except as provided below, vehicles and drivers will not be permitted to carry onboard computers, automated electronic recording devices, electronically actuated devices, smartphones/cell phones, watches, micro-processors, recording devices, filming devices, electronic digital memory chips, traction control devices, digital readout gauges and the like, even if inoperable or incomplete. Competitors will not be permitted to have or have had on his/her person or in his/her possession or in his/her vehicle a device(s) at an Event designed specifically to enhance the traction capabilities of the vehicle, even if inoperable or incomplete.

B. For broadcasting and media related purposes, ARCA may allow or require selected vehicles to compete with broadcast telemetry or other positioning and informational systems. Unless otherwise authorized or required by ARCA, the broadcast telemetry signal from these systems will be limited to the following parameters:

1. RPM (inductive pickup on the secondary wire only).
2. Transmission gear selection.
3. MPH (taken from sensors on the drive shaft or rear wheel only).
4. Brake pedal application.
5. Throttle position indicator (must not be attached to the carburetor).
6. Camera positioning and video switching.
7. All camera locations and styles must be approved by ARCA.
8. Upon request of ARCA Officials, Competitors must install the required camera(s) and broadcast system(s) in a manner and location acceptable to ARCA Officials.

C. All vehicles must be equipped with an approved Race Safe System at all tracks. The Race Safe System must be the dash mounted safety light or the Holley Pro Dash 12.3 Digital Dash part #553-111 equipped with a functioning Race Safe safety light (serviced by Racing Electronics). When the LED dash mounted safety light is used it may be mounted on top or the front of the dash but must be mounted to the left side of the steering column. The Battery must be mounted to the diagonal bar (#7A) in a position to allow the system to be checked from outside the vehicle.

D. ARCA may require vehicles to carry an IDR (Incident Data Recorder) mounted in a standard location and manner determined by ARCA. When required competitors must take whatever necessary steps provided by ARCA for the installation of the IDR (Incident Data Recorder). ARCA shall own any and all data generated and/or collected by such accelerometers and shall control the use and dissemination of such data.

E. Two (2) ARCA-approved timing and scoring transponder mounting brackets must be installed. One (1) on the left and one (1) on the right side of the fuel cell

container, 14 feet, two (2) inches rearward of the leading edge of the front of the vehicle to the front edge of the transponder bracket, mounted vertically with the square tab on the bottom, not higher than the bottom of the container. The brackets must be fastened with 3/16 inch diameter small head pop rivets (from the outside) through the holes in the center of the bracket with 3/16 inch diameter rivet washers on the inside. As an option, magnetic steel transponder brackets welded to the rear sub-frame side rails will be permitted. When approved weight containers interfere, the transponder bracket must be welded to the outside vertical surface of the weight container.

F. ARCA may require vehicles to carry ARCA-approved on-board data loggers equipped with designated sensors mounted in a standard location and manner approved by ARCA. ARCA shall own any and all data generated and/or collected by such data loggers and shall control the use and dissemination of such data. All competitors must cooperate with ARCA Officials with the installation and operation of such data logging systems.

Each vehicle will be required to have a separate wiring harness designated for the sole purpose of connecting to the on-board data loggers. The wiring harness connector must be located on the second from the top right side door bar (#9B) directly below the right side vent window bar (#10). The wiring harness must consist of a Deutsch DT06-2s plug assembly with socket 1F containing a red 14 gage wire that extends and connects to the master shut off switch on the terminal that supplies 12 volts when the master shut off switch is in the on position and socket 2S containing a black 14 gage wire that extends and connects to a ground stud mounted on the dash bar (#8). The wires may be covered with heat shrink for protection. The wiring harness must be separate from the ignition system wiring harness. A Deutsch part number 1011-344-0205 dust cap may be installed when the plug assembly is not in use.

G. Unapproved remote lap timing or speed sensing devices will not be permitted.

H. All electrical wiring harnesses, switches and connectors must be acceptable to ARCA Officials. All wiring must be point-to-point and each wiring connection must be easily traceable and removable from the vehicle for inspection purposes.

I. Competitor's use of filming and recording devices will be limited to internal review of pit stops only and not for promotion, resale or other commercial exploitation without ARCA's prior, written approval. Filming or recording device(s) will not be permitted on board the race vehicle at any time unless previously approved by ARCA.

J. Electronic oil, water and fuel pressure gauges and oil and water temperature gauges must be approved by ARCA and they must be completely independent of the ignition system. All gauge sending units and sensors must be located forward of the front firewall above the engine. When using a common manifold type mount for multiple sensors and sending units, an air gap space must be visible between each sensor or sending unit mounting port.

K. Gauges used in competition, including but not limited to tachometer, oil pressure gauge, oil temperature gauge, water temperature gauge and voltmeter, must be installed and functional at all times during competition.

L. A digital dash display may be used. Only the following digital dash's and wiring harnesses will be permitted:

<u>MANUFACTURER</u>	<u>PART NUMBER</u>
Holley EFI Pro Dash 12.3 (ARCA Ilmor engines) Holley Wiring Harness	553-111 558-449
Holley Standalone Pro Dash 12.3 (Carbureted) (ARCA-approved "Spec", Built and Legacy Engines) Holley Service Wiring Harness	553-116 558-457

The Holley service wiring harness part# 558-457 must be used when converting a vehicle with an ARCA-approved Ilmor engine to an ARCA-approved "Spec", Built or Legacy engine.

Only one (1) digital dash display will be permitted in the vehicle at any time. The digital dash display must be securely mounted using positive-threaded, magnetic steel fasteners. Vibration mounts are recommended. The digital dash display must be used exactly as supplied from the manufacturer. Internal and/or external modifications to the digital dash display will not be permitted. The digital dash display must only receive data through the approved wiring harness. During Competition, the digital dash display must be set for "Race Mode" and will be verified by ARCA inspection equipment. Screen covers or privacy filters that hinder in-car camera broadcasting of the digital dash display screen will not be permitted.

M. Ignition and accessory switches and interrupter system components must be installed and functional at all times during competition.

N. All electrical outlets used to connect the remote generator to the vehicle must be located behind the driver's seat but not further rearward than the "B" post on the left side or secured in the left "B" post.

O. Water bottles must not be in the vehicle during qualifying. Hydration systems,

when used, must be installed in the same location for qualifying and the Race. The containers must be securely mounted to the chassis in a manner acceptable to ARCA Officials.

P. For all road course Events, all vehicles must be equipped at all times with a rear window flashing light part #40R00FRN and should be equipped with a functional defogger and a windshield wiper motor. The defogger must draw air from inside the driver's compartment only. The use of heater cores and heat exchangers will not be permitted. The rear window flashing light must be an independent system and must be activated during all wet weather conditions. The rear window flashing light must be located inside of the upper left section of the rear window. Installation of all components must be acceptable to ARCA Officials.

Q. For all road course and dirt Events, rear rain flaps (Part # AUT 562.072424) must be installed at all times during an Event. Rear rain flaps must be installed as shown in Diagram #12 In the rear pages of the Rule Book.

20C-6.8 In-Vehicle Radio Communications

A. The in-vehicle radio must be analog only and must not be capable of transmitting or receiving in a digitized, encrypted or scrambled format as determined by ARCA. Keypad style and/or password protected radios will not be permitted. Scanning and/or channel hopping transmissions to or from the in-vehicle radio will not be permitted. All transmissions to and from the in-vehicle radio must be in the 450.000MHz-470.000MHz range, and all in-vehicle radio transmitting and receiving frequencies (including squelch codes) should be registered annually in the ARCA Radio Data Base <http://freqcoordination.nascar.com>. All frequency changes must be updated prior to being used during an Event and confirmed by ARCA's Official Radio Supplier. The in-vehicle radio is not permitted to transmit or receive any type of telemetry (data) signal or information other than audio communications and must remain independent from any electronic system in the vehicle. Competitors will not be permitted to rebroadcast transmissions to or from the in-vehicle radio at any time during an Event. It is strongly recommended that all in-vehicle radio frequencies be licensed for use by the Federal Communications Commission (FCC) and meet all applicable regulations and guidelines.

B. Only ARCA-approved, two-way radios and one (1) radio push to talk button will be permitted. It is not permitted to have any frequency of any Competitor installed in the radio at any time.

C. Other than antennas that are approved for broadcasting and media related purposes only, a single, ARCA-approved, radio antenna, must be mounted on the exterior of the body, positioned not more than two (2) inches to the right or left of the roof centerline and in the center of the length measurement of the roof, will be permitted. A UHF-450-470MHz wire whip antenna with an NMO-style brass or steel antenna base and ground plane is recommended.

D. At all times during practice(s), qualifying and the Race the spotter must have radio communications with the driver and must monitor the ARCA frequency. Spotters must be in the designated spotter location at all times during competition. The radio frequency being used will be made available by ARCA Officials.

E. Driver to driver radio communications will not be permitted.

20C - 7 ENGINE COOLING SYSTEM

All engine cooling system components must be approved by ARCA. Each such part may thereafter be used until ARCA determines that such part is no longer eligible.

Icing, freon-type chemicals or refrigerants must not be used in or near the engine compartment.

20C - 7.1 Water Pump

A. Only aluminum mechanical water pumps turning in the same direction as the crankshaft rotation and in the approved location will be permitted.

B. Water pump impellers may be altered.

C. Coolant flow must be in the same direction as the approved production engine.

D. Only standard production V-type or flat type V-ribbed water pump drive belts will be permitted.

20C - 7.2 Fan / Fan Shroud

A. Engine-driven fans, if used, must be operational and belt driven from the crankshaft. Free spin or clutch type fans will not be permitted.

B. Electric engine cooling fans are optional. When an electric fan is used, it must be mounted parallel to the radiator.

C. If an engine-driven fan is used, it must be a standard magnetic steel fan with a minimum of four (4) blades and must meet the following requirements:

1. The minimum diameter of the fan must not be less than 14 inches.
2. The fan blades must be a minimum of 3-1/2 inches wide.

D. The installation, type and location of the fan(s) must be acceptable to ARCA Officials.

E. When an engine-driven fan is used, the shroud must cover the entire

circumference of the fan and must not extend more than one (1) inch rearward of the trailing edge of the fan blade. When an electric fan is used, shrouds or panels rearward of the radiator will not be permitted.

20C - 7.3 Radiator Ducts / Radiator Air Inlet

A. Composites will not be permitted for constructing radiator air ducts. When ducting air from the grille to the radiator and/or the oil cooler, the floor of the ductwork must be higher than the bottom of the front air dam by a minimum of one (1) inch. The top of the radiator air duct must not be below the top of the manufacturer's grille opening. The radiator air duct from the grille opening to the radiator must not be wider than the width of the outside of the front sub-frame rails. The floor of the ductwork may extend rearward a maximum of one (1) inch beyond the backside of the radiator. The floor panel, top panel, and side panels of the radiator ductwork must be stationary, non-adjustable panels. Air dividers must be acceptable to ARCA Officials.

B. A maximum of three (3), optional, lower panels may be installed below the radiator ductwork floor. The lower panels must be constructed of a maximum 3/16 inch thick aluminum. The maximum width of the center lower panel, including any other components (i.e., tubing, braces, straps, etc.), must not be more than 33 inches. The center lower panel may extend rearward to the center of the front sway bar tube. Left side and right side lower panels may be added to the center lower panel and extend outward to fill the area between the front fascia and the leading edge of the front wheel openings. The outer panels must not extend rearward of the leading edge of the front wheel openings. The lower panel(s) must remain flat for the entire length and width of the panel(s). The surface area of the outer panels may be reduced by removing material (drilling of holes). When material has been removed, additional panels and/or attachments will not be permitted. The outer panels must remain one (1) piece.

C. All air entering the radiator duct must enter through an approved radiator air inlet located in the lower portion of the front bumper cover. All radiator air inlet openings must be located and centered on the chassis longitudinal centerline. The use of approved radiator air inlet inserts will be permitted as described in subsection 3-7E.

D. The radiator air inlet openings must be covered with one (1) or two (2) layers of screen wire or perforated metal attached to the front bumper cover only. A one (1) inch wide metal strip to hold the screen wire to the front bumper cover may be installed on the outer edges of the radiator air inlets only. All grille opening coverings must be acceptable to ARCA Officials.

20C - 7.4 Radiator

A. The radiator must remain stock appearing. Radiator cores and tanks must be constructed from aluminum material. The radiator core must be a standard automotive fin and tube design acceptable to ARCA Officials. Bar and plate radiator cores will not be permitted. The radiator core must not be wider than the inside width of the front sub-frame rails. Radiator tanks must be installed on the sides of the radiator core. The radiator must remain in the standard position not to exceed two (2) inches from vertical.

B. Radiator dust or shaker screens will be permitted.

C. Radiator installation must be acceptable to ARCA Officials.

D. The radiator overflow tube must be located at the right cowl area ahead of the windshield. A one-half gallon minimum, one (1) gallon maximum, aluminum overflow container must be located in line with the overflow tube. Additional water tanks, reservoirs or containers used to increase coolant capacity will not be permitted.

E. All radiator cooling tubes must be operational. All cooling fins and tubes must be evenly spaced top to bottom and side to side and must remain at a 90 degree angle to the side tanks. The spacing and width must be acceptable to ARCA Officials.

F. Radiator hoses or hose and pipe combinations, between the engine and the radiator, must not exceed a maximum of two (2) inches inside diameter for the entire length of the assembly.

20C - 8 ENGINE LUBRICATION

All engine lubrication system components must be approved by ARCA. Each such part may thereafter be used until ARCA determines that such part is no longer eligible.

20C - 8.1 Oil

A. Any oil is permissible for use in any engine except the ARCA Ilmor engine.

B. When the ARCA Ilmor engine is used, teams must use the specific oil required by the engine supplier. Additives will not be permitted.

C. Combustion enhancing additives will not be permitted.

20C - 8.2 Oil Pressure

Oil pressure may be regulated at the discretion of the crew chief.

20C - 8.3 Oil Filters

Oil filters and breather caps acceptable to ARCA Officials will be permitted.

20C - 8.4 Oiling System

A. A dry sump oiling system must be used consisting of a single engine oil pump, a metal lubrication oil reservoir tank, approved oil lines, and an overflow expansion tank.

B. All oil must be pumped by the engine-driven engine oil pump. Additional oil pumps or re-circulating pumps will not be permitted.

C. The lubrication oil reservoir tank must be located behind the driver's seat and forward of the rear jacking bolt crossmember. The lubrication oil reservoir tank must be located to the right of the inside edge of the left side rear sub-frame rail and to the left of the driveshaft tunnel. The lowest component of the lubrication oil reservoir tank, including all connectors, oil lines, and fittings must not be located lower than the bottom surface of the main frame rails. The lubrication reservoir tank must be encased with a minimum 0.027 inch thick leak proof magnetic sheet steel box covered with a magnetic sheet steel top. The lubrication oil reservoir tank cover must not be fastened with quick release fasteners. The lubrication oil reservoir tank encasement flat cover must be bolted in place and remain securely fastened to the top perimeter of the lubrication oil reservoir tank encasement at all times during competition. Teams must take any steps necessary to ensure the integrity of the sealing of the oil reservoir tank flat cover to the top perimeter of the lubrication oil reservoir tank encasement, regardless of situations and/or conditions. The lubrication oil reservoir tank encasement and flat cover may be a maximum of four (4) inches higher than horizontal shoulder bar (#7). The left side of the lubrication oil reservoir tank encasement must be located to the right of the inside edge of the left side rear sub-frame rail. The right side of the lubrication oil reservoir tank encasement must not be located further to the right than a maximum distance of 25-1/4 inches from the inside of the left main frame rail. The distance of 25-1/4 inches is based on the distance between the main frame rails measured inside to inside of 52 inches. The distance will be proportionally calculated from varying ARCA-approved main frame rail widths as described in sub-section 20C-11.2A.

When the NASCAR-approved (Generation 5) frame and roll cage assembly is used refer to sub-section 3.4.5B for oil tank installation and encasement specifications.

The location and installation of the lubrication oil reservoir tank encasement must be acceptable to ARCA Officials. Hoses and/or vents will not be permitted on the oil reservoir tank encasement.

D. Unless otherwise authorized by the Series Director, the lubrication oil reservoir tank cannot be changed after inspection and must be used for the entire Event (practice, qualifying, and the Race).

E. Quick disconnect fittings will not be permitted.

F. Oil lines inside the driver's compartment will not be permitted.

G. Oil lines must not pass through or against the exhaust pipes.

H. Engine oil line protective guards may be installed below the engine oil lines located under the left side floorboard. Engine oil line protective guards must be constructed of aluminum. The front engine oil line protective guard must be a maximum of 5-1/2 inches wide by a maximum of 1/4 inch high and may extend a maximum of 10 inches rearward of the front edge of the left side floorboard forward section. The rear engine oil line protective guard must be a maximum of 5-1/2 inches wide by a maximum of 1/4 inch high and may extend a maximum of 10 inches rearward covering the back of the oil lines. The rear edge of the guard must not extend beyond the rear of the left side frame rail.

I. The engine oil system must have a functional, vented overflow expansion tank (a minimum of 1/2 gallon capacity should be used). The vent hose from the lubrication oil reservoir tank to the overflow tank must be protected by a covering acceptable to ARCA Officials. The location and installation of the tank must be acceptable to ARCA Officials.

J. The oil pressure line to the oil pressure gauge and/or the oil pressure sending unit must be stainless steel, full coverage, outer braid protected synthetic rubber hose attached with threaded, nipple design hose end fittings and should be covered with flame resistant covering acceptable to ARCA Officials.

20C - 9 ENGINE EXHAUST SYSTEM

The exhaust systems and components must be acceptable to ARCA Officials and meet the following minimum requirements.

20C - 9.1 Exhaust Headers

A. Exhaust tubing must not cross over or under the engine.

B. Coated headers will be permitted.

C. Thermal wrap will not be permitted on the exhaust headers or collectors.

D. Spacers will not be permitted between the cylinder head and the exhaust header flange. Only one (1) gasket maximum 0.075 inch thickness may be used

between the cylinder head and exhaust header flange.

E. When the approved "Spec Engine" is used only the headers supplied by the approved "Spec Engine" supplier will be permitted.

F. When the ARCA Ilmor engine is used the headers and collectors listed below are the only headers and collectors that will be permitted. The headers and collectors must be from the approved manufacturers and remain as supplied without any modifications.

Approved Manufacturers

Hooker
Kook's

Hooker

Headers:

<u>Part Number</u>	<u>Description</u>
70101361-RHKR	304SS 4 into 2 primary stepped header (pair)
70101361LW-RHKR	304SS 4 into 2 primary stepped header, left
70101361RW-RHKR	304SS 4 into 2 primary stepped header, right

Collectors:

<u>Part Number</u>	<u>Description</u>
7104304LW-RHKR	Y-pipe, 304SS 2-1/4" 2 into 1 round collector, left
7104304RW-RHKR	Y-pipe, 304SS 2-1/4" 2 into 1 round collector, right
7104305LW-RHKR	Y-pipe, 304SS 2-1/4" 2 into 1 oval collector 5.3" w outlet/5.2" L, left
7104305RW-RHKR	Y-pipe, 304SS 2-1/4" 2 into 1 oval collector 5.3" w outlet/5.2" L, right
7104306LW-RHKR	Y-pipe, 304SS 2-1/4" 2 into 1 oval collector 4.13" w outlet/6" L, left
7104306RW-RHKR	Y-pipe, 304SS 2-1/4" 2 into 1 oval collector 4.13" w outlet/6" L, right

Kook's

Headers:

<u>Part Number</u>	<u>Description</u>
103-0075	Primary header, left
103-0076	Primary header, right

Collectors:

<u>Part Number</u>	<u>Description</u>
103-0077	Secondary round collector, left
103-0078	Secondary round collector, right
103-0079	Secondary oval collector 5.25", left
103-0080	Secondary oval collector 5.25", right
103-0081	Secondary oval collector 4.13", left
103-0082	Secondary oval collector 4.13", right
103-0083	Primary offset collector (2 needed per side)
103-0084	Primary straight collector (2 needed per side)

20C - 9.2 Exhaust Pipes

A. All vehicles must have a complete exhaust pipe system at all times and exhaust pipe(s) must exit on the right side of the vehicle.

B. Exhaust pipe(s) from the exhaust header collector take-off must not be larger than 3-1/2 inches inside diameter when a round exhaust pipe(s) is used.

C. The exhaust pipe(s) must not exit more than 24 inches forward of the front edge of the rear wheel opening to the front edge of the exhaust pipe.

D. The exhaust pipe exit width must not exceed 11 inches for one (1) pipe or 22 inches for a combined two (2) pipe system.

E. The exhaust pipe(s) must extend outside the rocker panel but not to exceed a maximum of 1/4 inch.

F. The exhaust pipe(s) must be secured beneath the frame with a minimum of three (3) inches of ground clearance.

G. Frames, rocker and quarter panels must not be notched to accommodate exhaust pipes.

H. Exhaust pipes must be fastened to the headers in a secure manner acceptable to ARCA Officials.

I. All exhaust pipe connections must be a sealed, interference fit, and acceptable to ARCA Officials.

J. Each exhaust pipe must be secured to the vehicle with a minimum of two (2) 1/8 inch thick by a minimum of one (1) inch and a maximum of two (2) inches wide magnetic steel "U" shaped brackets.

K. Exhaust pipes must be made from magnetic steel tubing.

L. Thermal wrap will be permitted to be used on the exhaust pipe under the

driver's compartment area only.

M. Sound level requirements may be specified at designated tracks and will be noted on the Official Entry Blank for that Event.

20C - 10 DRIVE TRAIN

All drive train systems and drive train system components must be approved by ARCA. Each such part may thereafter be used until ARCA determines that such part is no longer eligible. All drive train fasteners and mounting hardware must be made of solid magnetic steel.

20C - 10.1 Clutch

A. Only mechanical foot pedal, cable or hydraulic operated clutches will be permitted. Pneumatic assisted clutches will not be permitted.

B. The clutch assembly must be bolted to the flywheel located inside the bell housing.

C. Only full circle fully faced magnetic steel clutch discs with a diameter of 7-1/4 inches will be permitted. Minimal cooling slots will be permitted in the clutch discs.

D. Multiple disc clutches will be permitted up to a maximum of three (3) discs. The disc clutch housing assembly and cover must be made from aluminum or steel. The clutch cover must be the push type design.

E. Only solid magnetic steel pressure plates and magnetic steel floater plates, without any holes will be permitted.

F. Clutches must be a positive engagement design. Slider or slipper clutch designs will not be permitted.

G. When the approved "Spec Engine" is used only the clutch assembly supplied by the approved "Spec Engine" supplier will be permitted.

H. When the approved "ARCA Ilmor Engine" is used, the clutch assembly must remain as supplied by the approved engine supplier without any modifications. Competitors will be permitted to remove, rebuild and install the clutch assembly.

20C - 10.2 Flywheel

Only a solid magnetic steel flywheel, bolted to the crankshaft, will be permitted. Holes and/or other modifications to the flywheel that, in the judgment of ARCA Officials, are for weight reduction will not be permitted.

20C - 10.3 Bell Housing

A. Only special production aluminum or magnetic steel bell housings acceptable to ARCA Officials will be permitted.

B. The maximum distance from the machined surface at the back of the engine block to the machined surface at the front of the transmission case must not exceed 6-3/8 inches including any spacers.

C. For all engine block-mounted starters, the starter mounting position must remain on the right side for Ford and General Motors engines.

D. When the approved ARCA Ilmor engine and "Spec Engine" is used, the bellhousing must remain as supplied by the approved engine supplier without any modifications.

20C - 10.4 Transmission

A. Transmissions must be standard production design. The transmission must be from an approved manufacturer. ARCA Officials may use a transmission provided by the respective manufacturer as a guide in determining whether a Competitor's transmission conforms to the specification of the Rule Book.

B. Unless otherwise specified by ARCA, the same transmission must be used for practice, qualifying, practice after qualifying and the start of the Race. A transmission must not be removed from a vehicle without the approval of the Series Director. The Series Director may require any team that removes a transmission to start at the rear of the field, providing the vehicle earns a starting position in the Race. The transmission may be removed from a backup vehicle, without a penalty, at the discretion of the Series Director as follows:

1. If a vehicle is wrecked beyond repair during qualifying and a backup vehicle is used, a transmission change may be permitted, however, the transmission must be installed before the beginning of practice(s), if practice(s) is scheduled, following qualifying.
2. If a vehicle is wrecked beyond repair during or after qualifying and a backup vehicle is used, then a transmission change may be permitted without an additional penalty.

If a Competitor violates this Rule, in addition to imposition of a penalty pursuant to Section 12, the Series Director may take appropriate action during the Event, including but not limited to, loss of practice time and/or loss of the opportunity to qualify, and/or confiscation of the transmission or transmission components. Such actions shall be deemed an inspection decision not subject to Section 12.

C. ARCA, at its discretion, may require that all vehicles compete with a final drive gear ratio specified by ARCA Officials for each Event.

D. The complete transmission assembly, as raced, must weigh a minimum of 80 pounds. This minimum weight will include the shifter assembly, internal oil pump

assembly (if used) and lubricant. This minimum weight will not include the shift lever and rear mount.

E. Only four (4) forward speed manual transmissions will be permitted.

F. All forward gears and reverse gear must be in working order.

G. Fourth gear ratio must be 1.00:1 (direct). Transmission gear ratios between 1.00:1 and 1.28:1 will not be permitted for the remaining forward transmission gears, except road course Events. Overdrive gears will not be permitted.

H. Fourth gear must be the primary gear engaged on all tracks, except road course Events, during competition.

I. All transmissions must have the input shaft and its main drive gear constantly engaged. This assembly must be constantly engaged with the countershaft and its cluster and reverse gears.

J. Only manual shift linkage using the H-pattern type will be permitted on the transmission. The shift lever must be metal. All shift rods connecting the shifter mechanism to the transmission must be made of metal.

K. Only fire resistant type shifter boots will be permitted. The shifter boots must meet the SFI 48.1 specification and display a valid SFI 48.1 label visible on the outside surface of the shifter boot. Shifter boots must not be used beyond two (2) years from the date of manufacture. Quick release fasteners will not be permitted to secure the shifter boot to the transmission tunnel. The shifter boot, when installed, must mount directly to the transmission tunnel and must be completely sealed. Installation of the shifter boot must be acceptable to ARCA Officials.

L. Only external threaded-type probe heaters into liquid, acceptable to ARCA Officials, will be permitted to heat the transmission. Heating pads and/or blankets will not be permitted for warming the transmission.

M. External transmission oil coolers acceptable to ARCA Officials will be permitted. Quick disconnect fittings on the oil lines will not be permitted. Transmission oil cooler pumps must be mechanically driven. Transmission lubrication systems must be of the wet sump design only. (Electric pumps will not be permitted).

N. Transmission vent/breather hose and filler assemblies must be located within the transmission tunnel and must not extend forward of the vertical front firewall. Remote transmission reservoirs and/or fill tubes will not be permitted.

O. All transmissions must be prepared with two (2) top cover or side cover bolts and two (2) tail housing bolts and two (2) transmission to bell housing bolts drilled to accept installation of a 1/8 inch minimum diameter ARCA seal.

20C - 10.5 Drive Shaft

A. The drive shaft, universal joints and yokes must be magnetic steel. Only a one-piece magnetic steel drive shaft with a minimum diameter of 3-1/2 inches and a minimum thickness of 0.065 inch will be permitted. All drive shafts must be painted white.

B. Two (2) 360 degree solid magnetic steel brackets, not less than two (2) inches wide and 1/4 inch thick, must be placed around the drive shaft. The front bracket must be welded to the rear suspension crossmember and the rear bracket must be welded to the horizontal tunnel bar (#6).

20C - 10.6 Rear Axle

A. Only Ford 9" design rear axle housings will be permitted and must meet the following requirements:

1. Only a one-piece all-magnetic steel rear end axle housing will be permitted.

Only magnetic steel axle tubes with a minimum three (3) inch outside diameter and a minimum 0.219 inch wall thickness meeting ASTM A-513 Type 5 specification will be permitted. The axle housing center section must be made of magnetic steel with a minimum thickness of 0.187 inch meeting ASTM A-569 series specification.

2. The carrier housing and related components must be made of magnetic steel. The carrier housing must be from an approved manufacturer. The following carrier housing is approved for competition:

Ford M-4141 – (B), (E), (H), (HS) or (J)

3. The rear axle ring and pinion must be the Ford 9" design.

4. Only approved magnetic steel Detroit locker-type differentials acceptable to ARCA Officials will be permitted for the Ford 9" design. When the locker-type differentials are used, either wheel, when jacked up with the transmission engaged, must permit either wheel to turn freely by hand for one (1) full turn-360 degrees, while the opposite wheel remains stationary. The locker-type differential must be from an approved manufacturer. Any major design modifications to an approved locker assembly must be submitted to ARCA for approval prior to use in competition. A minimum of 10, solid 7/16 inch diameter, hex head or 12 point cap screws must be installed attaching the ring gear to the differential locker housing at all times during competition.

B. Full floating magnetic steel double splined rear axles must be used. Hollow or drilled rear axles will not be permitted. The rear axle outer drive spline must be 24-spline, not less than 1-1/4 inches long, and must have a maximum outside

diameter of 1.562 inches. Inner rear axle splines must be straight without any crown.

C. Only standard production, 24-spline, magnetic steel drive plates will be permitted. Magnetic steel drive plates may be either a one-piece or a two-piece design. Grease fittings will not be permitted on the drive plates or axle caps.

D. Rear end differential oil coolers, acceptable to ARCA Officials, will be permitted. If used, the rear end differential oil cooler must be mounted directly to the rear firewall, outside the driver's compartment and must not be lower than the top of the main frame rails. A protective guard constructed of aluminum or screen wire may be used. The protective guard cannot be larger than 1/2 inch of the outside dimension of the rear end differential oil cooler. Rear end differential oil cooler boxes will not be permitted. Quick disconnect fittings on the oil lines will not be permitted. Rear end differential oil pumps must be mechanically driven. Rear end lubrication systems must be of the wet sump design only. (Electric pumps will not be permitted). Remote rear end differential reservoirs and/or fill tubes will not be permitted.

E. Camber will be checked using ARCA gauges. Camber will be checked with air pressure set at the tire manufacturer's recommended technical inspection inflation pressures for the Event. The maximum rear axle housing camber on both the left and right side that will be permitted, will be plus or minus (+/-) 2 degrees.

F. Total rear wheel alignment including axle housing toe and housing alignment in the chassis, must not exceed 0.250 inch when measuring from the inside surface of the ARCA wheelbase gauge to the outer most surface of the tire sidewall. The axle housing including all components (hubs, brake hats and wheel spacers), must be centered between the frame rails with a maximum of one (1) inch offset to the right side only. When measuring the total rear wheel alignment including axle housing toe and axle housing offset the track bar must be horizontally level.

G. If axle housing support bars are used, only one (1) end may be adjustable to change the length of the bar.

H. Only external threaded-type probe heaters into liquid, acceptable to ARCA Officials, will be permitted to heat the rear end assembly. Heating pads and/or blankets will not be permitted for warming the rear end assembly.

I. ARCA may, at its discretion, require that all vehicles compete with a final drive gear ratio specified by ARCA Officials for each Event.

J. An axle housing may not be changed at an Event without the authorization of the Series Director and must be inspected before installation.

20C - 10.7 Wheels / Lug Bolts / Lug Nuts

A. Wheels must be from an approved manufacturer. Wheels must be SFI-approved, and meet the SFI 35.1 specification, display a valid label and must be acceptable to ARCA Officials.

B. Only 15 inch diameter five (5) lug steel wheels weighing a minimum of 27 pounds (uncoated without valve hardware) with a 9-1/2 inch rim width and a 4-1/2 inch offset (backspacing) reinforced center will be permitted.

C. Only approved wheels with two (2) valve stem holes will be permitted. One (1) valve stem hole must be located at the outer edge of the wheel as designated by the tire manufacturer. The second valve stem hole must be located either in front of the wheel center or in a window of the wheel center just behind the edge of the wheel center. Wheel center windows must remain open at all times.

D. Valve stem hardware specified by the tire manufacturer must be used. Valve stem caps must be installed at all times during competition.

E. Any device, modification or procedure to the tire, wheel or valve stem hardware, that in the judgment of ARCA Officials is used to release pressure (beyond normal pressure adjustments) from the tire and/or inner shield, will not be permitted.

F. All wheels must have a single vehicle number visible with 1-1/4 inch high numbers on the inside and outside of the rim.

G. Only solid, one-piece heavy-duty 5/8 inch diameter by 18 threads per inch magnetic steel lug bolts will be permitted. The same style lug bolt must be used for practice, qualifying and the Race. Design modifications to the lug bolts will not be permitted.

H. Only standard one (1) inch hex by minimum 0.650 inch thick, fully-threaded, solid, one-piece magnetic steel lug nuts, with a maximum cross-section of one (1) inch (measured on the flat), tapered on one (1) side and flat on one (1) side will be permitted. The first thread on each lug bolt must be visible from the front of the lug nut when the lug nut is installed. Design modifications to the lug nuts will not be permitted.

I. Electroplated wheels will not be permitted.

20C - 10.8 Tires

Only approved tires will be permitted. Approved tires are those tires that comply with the requirements of this rule and are recommended in writing, with prior notification to ARCA, by the ARCA-approved tire manufacturer for use by Competitors in the Event.

20C - 10.8.1 Physical Requirements

A. All four (4) tires must be of the same make, and the same tread design.

B. On all tracks specified by ARCA, inner shields must be used.

20C - 10.8.2 Tire Manufacturer Obligations

A. The tire manufacturer must provide ARCA with the following information in writing two (2) weeks prior to the date of the Event:

1. Tire identification markings for each tire must be unique to one (1) particular size, construction and rubber compound combination.
2. The recommended position on the vehicle for each tire being used in the Event.

B. The same tires must be made available to each Competitor.

20C - 10.8.3 Tire Measurement Procedure

A. Tires must not exceed a maximum sidewall measurement of 13.65 inches at 30 pounds air pressure mounted on a 15 inch wheel with a 9-1/2 inch rim width.

B. ARCA Officials will use an ARCA-approved measuring device to measure the size of new tires. New tires may be selected at any Event by ARCA Officials for measurements.

20C - 10.8.4 Tire Usage Rules

A. All tires must be used in approved positions. Approved positions are those positions on the vehicle recommended in writing, with prior notification to ARCA, by the ARCA-approved tire manufacturer for its tires used by Competitors in the Event.

B. Unless otherwise authorized by the Series Director, all tires to be used for practice or qualifying must be purchased and mounted at the Event from the ARCA-approved tire supplier.

C. Unless otherwise authorized by the Series Director, at all tracks teams will be required to use sticker tires (new tires) for qualifying.

D. Immediately following a qualifying attempt, wheels and tires from all qualified vehicles may be impounded by ARCA Officials. Unless otherwise authorized by the Series Director, all tires used in qualifying must be used for the start of the Race. The impounded tires will be returned when the vehicles are prepared for the Race. If the tires are removed from the vehicle, the tires must be replaced in the positions on the race vehicle from which they were removed.

E. Unless otherwise authorized by ARCA Officials, Competitors will not be permitted to make tire changes prior to the completion of the first official green flag lap of the Race.

F. The Series Director may approve the replacement of an impounded tire when recommended by the tire manufacturer's representative without a starting position penalty provided the replacement tire carries the same manufacturer identification number as the tire used for qualifying.

G. The ARCA-approved tire supplier may re-balance, re-mount or change inner shields under the supervision of ARCA Officials.

H. Tire or wheel warming, using heaters, blankets, micro-wave or any other method will not be permitted.

I. When required, the inner shield must be the same brand as the tire manufacturer.

J. Should identification numbers, code numbers or serial numbers be defaced on any previously approved tire(s), the tire(s) will be ineligible for competition.

K. Tires that, in the judgment of ARCA Officials, have been altered by unauthorized treatment will not be permitted.

L. Hand grooving, buffing, grinding, and/or cutting on any area of the tire will not be permitted.

M. The Series Director may establish a tire change rule for the particular Event being run. This rule shall be made known to all the Competitors at the Pre-Race driver's meeting.

N. Tire cooling fan and hose assemblies will only be permitted on oval tracks 1-1/4 miles or more in length. When used only one (1) tire cooling fan and hose assembly with a maximum hose diameter of three (3) inches will be permitted for each front tire. The fan must be mounted behind the front bumper cover and a minimum of four (4) inches above the lower edge of the front bumper cover (front valance is not included in the measurement). The fan and hose assembly cannot draw air through the radiator duct work. The hose assembly outlet must be a minimum of six (6) inches inward from the outer edge of the fender opening. The hose assembly must be securely mounted and remain stationary. Mounting of the fan assembly must be acceptable to ARCA Officials.

O. Competitors presenting vehicles for inspection must have their tires inflated to the recommended technical inspection inflation pressures as specified by the participating tire manufacturer for the Event. If tire pressure(s) are not at the recommended technical inspection inflation pressures after competition, tires will be adjusted to the recommended technical inspection inflation pressures as specified by the participating tire manufacturer for the Event.

20C - 11 FRAMES

All frames and frame components must be approved by ARCA. Each such part may thereafter be used until ARCA determines that such part is no longer eligible.

20C - 11.1 General Frame Eligibility

All frames must be acceptable to ARCA Officials. All frames must have a legible unpainted identification code stamped into the roll cage on the right side of horizontal shoulder bar (#7) near the intersection with the main roll bar (#1). This code will include in this order: the builder, date of manufacture, and a sequence number (example - BPC-1099-53). The frame used must meet the minimum requirements described in the following paragraphs. All frame designs must be submitted in blueprint form for acceptance to the NASCAR R&D Center in Concord, North Carolina at least 60 days before the design can be entered in competition. If ARCA Officials accepts the modification as set forth in the submitted blueprints, the Competitor must submit for inspection a completed frame and roll cage at least 30 days prior to the intended date of competition. Acceptance of the submitted blueprint does not guarantee acceptance of the completed frame and roll cage design, and ARCA Officials may decide not to accept such design even if it is the same as the blueprint form. If ARCA Officials accept the completed frame and roll cage, it may thereafter, be used in competition in the form accepted, unless and until the form is no longer approved by ARCA Officials.

The NASCAR-approved (Generation 5) frame and roll cage assembly consisting of main frame rails, upper left side frame rail, trailing arm crossmember assembly, rear sub-frame assembly and numbered roll bars (#1 through #19) will be permitted. The frame and roll cage assembly must be ARCA-approved and meet the specifications and dimensions as described in sub-sections 20C-11.2 (Frame Requirements), 20C-18 (Roll Bars) and shown in Diagrams (#1A through #1C, 2A through 2C and 3A & B) in the rear pages of the Rule Book. The addition or removal of frame components or Roll bars, from the front roll bar legs (#2A & B) to the rear sub-frame crossmember, will not be permitted.

If the NASCAR-approved (Generation 5) frame and roll cage assembly is used, it must be used for 110 inch wheel base vehicles only.

The NASCAR-approved (Generation 5) frame and Roll cage assembly is not required to be submitted to ARCA for certification but must be acceptable to ARCA Officials.

Modifications to any frame components that, in the judgement of ARCA Officials, were made to circumvent any ARCA inspection processes and/or measurement equipment or gauges will not be permitted.

20C - 11.2 Frame Requirements

All frame components must be made of magnetic steel and welded. The frame must consist of a front and a rear sub-frame connected to the main frame on which the roll cage is welded. Sub-frames must not be offset from the main frame longitudinal centerline. Holes and/or other modifications to the frame, frame supports, weight containers, front and rear sub-frames, crossmembers, or any other frame components that, in the judgment of ARCA Officials, were made with the intent of weight reduction will not be permitted.

A. Main Frame - The main frame must consist of two (2) side rails of magnetic steel box tubing three (3) inches in width by four (4) inches in height with a minimum wall thickness of 1/8 inch meeting the ASTM A-500 specification with a minimum length of 65 inches. These frame rails must be parallel to each other and parallel to the chassis longitudinal centerline with a minimum distance between the frame side rails measured inside to inside of 50 inches for 110 inch wheelbase vehicles and 52 inches for 105 inch wheel base vehicles with a maximum outside to outside frame rail width of 60 inches. A crossmember, a minimum of two (2) inches in height by two (2) inches in width with a minimum wall thickness of 1/8 inch meeting the ASTM A-500 specification must be placed between the main frame rails to support the mounting location for the rear suspension trailing arms. These mounting locations must not be offset from the main frame rail longitudinal centerline. Added weight containers, welded to the main frame rails, must be the same section as the main frame rails with a minimum wall thickness of 0.083 inch meeting the ASTM A-500 specification.

B. Front Sub-Frame - The front sub-frame rails must be made of magnetic steel box tubing two (2) inches in width by three (3) inches in height with a minimum wall thickness of 0.083 inch meeting the ASTM A-500 specification. The front sub-frame must extend from the lower radiator support rearward to the forward end of the main frame rails, incorporating the attachments for the steering linkage, suspension and engine. The length of the front sub-frame front rails when measured from the center of the front jacking bolt forward must be a minimum of 25-1/2 inches. The inside width of the front sub-frame rails must be a minimum of 29 inches at the steering box mount and they must be parallel to the longitudinal centerline. The sub-frame front rails must remain parallel to the longitudinal centerline of the main frame. The inside width of the front sub-frame rear rails (rails extending from the center of the jacking bolt rearward), measured inside to inside at the rear of the engine block, must not exceed 34 inches. The front sub-frame must connect to the main frame rail by welding the sub-frame attachment point to within three (3) inches of the end of the main frame rail. Only coil spring front suspension may be used. The jacking

bolts must be solid magnetic steel and must align within plus or minus (+/-) one (1) inch of the spindle centerline (at zero (0) degrees caster). At any point along the sub-frame rails, the distance to each rail from the longitudinal centerline must be the same. Any supports added to the front sub-frame crossmember forward to the front sway bar tube must meet the ARCA front crossmember support template.

C. **Rear Sub-Frame** - The rear sub-frame rails must be made of magnetic steel box tubing two (2) inches in width by three (3) inches in height with a minimum wall thickness of 0.083 inch meeting the ASTM A-500 specification and with a minimum inside rail width of 37 inches measured at the fuel cell mounting location. The rear sub-frame rails must extend rearward from the main frame rails up and over the rear axle, down and back, and must remain parallel with the main frame rails at the fuel cell mounting location as viewed from the side. The rear sub-frame must incorporate the mounting locations for the rear springs, shock absorbers, track bar, sway bar and fuel cell ending with a crossmember that must be two (2) inches in width by three (3) inches in height with a minimum wall thickness of 0.083 inch meeting the ASTM A-500 specification. The rear crossmember must be located a minimum of eight (8) inches behind the fuel cell recessed well. For 110 inch wheelbase vehicles, the rear sub-frame rails must connect to the main frame rails not less than 57 inches from the front end of the main frame rails. For 105 inch wheelbase vehicles, the rear sub-frame rails must connect to the main frame rails within five (5) inches of the rear end of the main frame rails. At any point along the sub-frame rails, the distance to each rail from the longitudinal centerline must be the same. The rear support bars (#13 A & B) must extend to the rear of the sub-frame rails to within one (1) inch of the rear edge of the fuel cell. Other than the bottom support frame for the fuel cell recessed well, as described in sub-section 20C-16.3F, nothing may be mounted lower than the bottom of the fuel cell recessed well behind the rear axle housing.

D. The frame and roll cage assembly must be painted using only light/bright colors.

When the NASCAR-approved (Generation 5) frame and roll cage assembly is used it must meet the following specifications. Modifications to any of the specifications or components will not be permitted.

Frame Requirements

All frame components must be made of magnetic steel and welded. The frame must consist of a front and a rear sub-frame connected to the main frame on which the roll cage is welded. Sub-frames must not be offset from the main frame's longitudinal centerline. Each of the frame's crossmembers must include a visible, permanently marked centerline reference location point that can be viewed from above and below the vehicle.

Holes and/or other modifications to the frame, frame supports, weight containers, front and rear sub-frames, crossmembers, or any other frame components that, in the judgment of ARCA Officials, were made with the intent of weight reduction will not be permitted. Frame construction materials must remain as described in this sub-section as they relate to specified sizes and specified shapes. Grinding, machining and/or other modifications to the frame components that, in the judgment of ARCA Officials, changes the components size and/or shape, as described in the ARCA Rule Book, will not be permitted. All references to the inspection surface in sub-section 20C-11.2 have been determined with the front lower edge of both main frame rails set at six (6) inches and the rear lower edge of both main frame rails set at eight (8) inches from the horizontal inspection surface.

For inspection purposes, a conical receiver for a 3/4 inch outside diameter locating ball must be welded to the bottom surface of the trailing arm crossmember. This receiver must be located on the longitudinal centerline of the chassis and centered forward and rearward on the trailing arm crossmember. The distance from the center of the conical receiver and the rear vertical surface of the trailing arm crossmember (X = zero) must be one (1) inch to provide accurate placement of all chassis components and body location in the "X" direction.

The front sway bar tube must have a 1/8 inch diameter or a 1/4 inch diameter hole on the chassis longitudinal centerline on the top of the tube.

A. **Main Frame** - The main frame and crossmember assembly must meet the specifications and dimensions as described in this sub-section and shown in Diagram #1A, in the rear pages of the Rule Book. The main frame must consist of two (2) side rails of magnetic steel box tubing (alloys other than mild steel will not be permitted), three (3) inches in width by four (4) inches in height with a minimum wall thickness of 0.113 inch meeting the ASTM A-500 specification with a length of 65 inches. The front and rear ends of both main frame rails must be cut square. The main frame rails must be straight. The main frame rails must be a continuous and consistent length of three (3) inches in width by four (4) inches in height, box tubing. Tapered, bent or distorted frame rails will not be permitted. The main frame rails must be parallel to each other and parallel to the chassis longitudinal centerline with a distance between the frame side rails, measured inside to inside, of 52 inches. An upper frame rail must be used in conjunction with the left side main frame rail. This upper frame rail must be constructed using magnetic steel box tubing two (2) inches in width by five (5) inches in height with a minimum wall thickness of 0.113

inch, meeting the ASTM A-500 specification. The upper frame rail must be welded to the top of the main frame rail flush with the outside vertical wall and be welded to the main roll bar (#1) and the left front roll bar leg (#2A) (see Diagram #2B, in the rear pages of the Rule Book). This upper frame rail must be welded to and continue forward from the front of the left front roll bar leg (#2A) to the forward end of the left main frame rail. This upper rail must then angle inward to align with and be welded to the top surface of the left sub-frame rail (see Diagrams #2B & 3B, in the rear pages of the Rule Book). A trailing arm crossmember, which includes the right and left trailing arm mounting brackets and the front drive shaft hoop and tunnel plate assembly, must be constructed and located between the left and right main frame rails. The trailing arm crossmember must be constructed using two (2) inches wide by two (2) inches high square magnetic steel tubing with a wall thickness of 1/8 inch, meeting the ASTM A-500 specification. The trailing arm crossmember must be cut in half in the center of the chassis and reconnected using two (2) inch wide by one (1) inch high rectangular tubing with a minimum wall thickness of 0.113 inch, meeting the ASTM A-500 specification, and be welded beneath the left and right crossmember sections. The center connection must also include the front drive shaft hoop and tunnel plate assembly (see Diagram #1C, in the rear pages of the Rule Book). The left half of the trailing arm crossmember must be welded to the inside vertical wall of the left side main frame rail at a distance of 31 inches forward of the rear end of the left main frame rail to the back of the crossmember. A six (6) inch high by minimum four (4) inch long by two (2) inch wide triangular shaped gusset must be installed to connect the top surface of the left trailing arm crossmember to the inside vertical wall of the left upper frame rail. This gusset must be constructed of a minimum 0.113 inch thick, rectangular, magnetic steel box tubing and completely welded in place. Holes and/or other modifications that, in the judgment of ARCA Officials, were made with the intent of weight reduction will not be permitted. The right half of the trailing arm crossmember must step up to provide exhaust pipe clearance and be welded to a welded mount on top of the right side main frame rail at a distance of 31 inches forward of the rear end of the right side main frame rail to the back of the crossmember (see Diagram #1A, in the rear pages of the Rule Book).

The trailing arm mounting brackets must be welded to the back of the crossmember and must not be offset from the main frame rail longitudinal center line. As a mounting option, ARCA-approved bolt-on trailing arm mounting brackets may be used. Once approved, the bolt-on trailing arm mounting brackets must be used as submitted. The horizontal centerline of the highest trailing arm mounting bolt holes must not be higher than the top of the trailing arm crossmember (10-5/16 inches) at the location of the trailing arm mounting bracket. A left and right side diagonal brace must support the trailing arm crossmember rearward to the inside of its respective main frame rail. The diagonal braces must be constructed using two (2) inches wide by one (1) inch high rectangular magnetic steel tubing with a minimum wall thickness of 0.075 inch, and a maximum wall thickness of 0.120 inches, meeting the ASTM A-500 specification. These diagonal braces must be welded to the trailing arm crossmember near the trailing arm mounting brackets and to the inside of the main frame rails, not more than nine (9) inches from the back edge of the main frame rails. Rearward diagonal braces must be straight as viewed from all directions.

A left and right side diagonal brace must support the trailing arm crossmember forward to the respective front sub-frame side rail. The diagonal braces must be constructed using rectangular magnetic steel box tubing with a minimum wall thickness of 0.075 inch, meeting the ASTM A-500 Specification. These diagonal braces must be welded to the front of the trailing arm crossmember near the front driveshaft hoop and near the rear of the respective front sub-frame side rails. The entire right side forward diagonal brace, at the trailing arm crossmember, must be located no more than 11 inches to the right side of the chassis longitudinal centerline. Forward diagonal braces must be straight as viewed from above.

The left side jack post must be constructed from 1-1/4 inch outside diameter round magnetic steel tubing with a maximum wall thickness of 0.083 inches (nominal). The jack post main tube must extend upward and inward at an angle from the rocker panel and be welded to the anti-intrusion plate above the left side door bar (#9A-3). The jack post main tube must be supported by angular struts constructed from a maximum 3/4 inch diameter round, magnetic steel tubing with a maximum wall thickness of 0.065 inch (nominal). These angular struts must be welded to the left main frame rail either at the bottom of the rail or at the intersection with the upper main frame rail. The distance between the struts at each weld must not be less than eight (8) inches and not more than 10 inches. The struts must have a slight angular bend or radius formed into the strut near the center to initiate crush of the strut inward during impact.

The right side jack post may be constructed in a similar manner although it may be welded to the side of the right side door bar (#9B-3 or #9B-4).

B. Front Sub-Frame - The front sub-frame rails must be made of magnetic steel box tubing (alloys other than mild steel will not be permitted), measuring two (2) inches in width by three (3) inches in height with a minimum wall thickness of 0.075 inch meeting the ASTM A-500 specification. The left side forward sub-frame section which incorporates the mounting brackets for the steering box must be constructed

of the material described above but may have a maximum wall thickness of 0.120 inch. The front sub-frame must extend from the lower radiator support rearward to the forward end of the main frame rails, incorporating the attachments for the steering linkage, suspension and engine. All sub-frame components must be completely welded. The length of the front sub-frame front rails when measured from the center of the front jacking bolt forward must be a minimum of 25-1/2 inches. The forward sections (two (2) inches wide by three (3) inches high box tubing) of the right side and left side front sub-frame front rails must be located with a minimum of a nine (9) degree drop from the front spring bucket to the front of the sub-frame rail. The forward ends of the right side and left side front sub-frame rails may be narrowed for radiator tank clearance. A dimension of three (3) inches high by a minimum of one (1) inch wide must be maintained to a minimum length of 25-1/2 inches forward of the center of the front jacking bolt. The inside width of the front sub-frame rails must be a minimum of 29 inches and a maximum of 30-1/2 inches at the steering box mount and they must be parallel to the longitudinal centerline. The inside width, measured at the rear of the engine block, must not exceed 36 inches. The front sub-frame must connect to the main frame rail by welding the sub-frame attachment point to within three (3) inches of the front end of the main frame rail. Only coil spring front suspension may be used. The jacking bolts must be solid magnetic steel and must align within plus or minus (+/-) one (1) inch of the spindle centerline (at zero (0) degrees caster). At any point along the sub-frame rails, the distance to each rail from the longitudinal centerline must be the same. The distance from the longitudinal centerline of the front sub-frame rails to the lower a-frame mounting points and the front jacking bolt mounting points must be equal left and right. The bottom surface of the lower A-frame mounting brackets may be supported rearward to the respective back sections of the front sub-frame side rails and forward to the front sway-bar mounting tube. Each support must be constructed of solid magnetic steel, rectangular flat plate with a maximum thickness of 3/8 inch and a maximum width of two (2) inches or hollow magnetic steel rectangular box tubing with a maximum wall thickness of 1/8 inch, a maximum width of two (2) inches and a maximum height of one (1) inch. Each support must be constructed using dimensionally equal materials on the left and right sides and must remain as straight as possible when viewed from above, contact the sway-bar mounting tube at a maximum distance of four (4) inches left or right of the chassis longitudinal centerline, and be completely welded in place.

An additional, lateral crossmember may be located between the left and right forward lower A-frame mounting brackets. The lateral crossmember must be constructed of magnetic steel, rectangular flat plate with a maximum thickness of 3/8 inch and a maximum width of three (3) inches or hollow magnetic steel rectangular box tubing with a maximum wall thickness of 1/8 inch, a maximum width of three (3) inches and a maximum height of 1-1/2 inches and completely welded in place. Any supports added to the front sub-frame crossmember forward to the front sway bar tube must meet the ARCA front crossmember support template.

A crossmember made of 3/4 inch by 1-1/2 inches by 0.120 inch thick rectangular magnetic steel box tubing must connect the rear most sections of the front sub-frame rails, located against the front firewall, above the bell housing (see Diagrams #2A, B & C, in the rear pages of the Rule Book). This rectangular crossmember must not be cut when intersecting diagonal bar (#7A).

C. Rear Sub-Frame - The rear sub-frame rails must be made of magnetic steel box tubing (alloys other than mild steel will not be permitted), measuring two (2) inches in width by three (3) inches in height with a minimum wall thickness of 0.075 inch meeting the ASTM A-500 specification and with an inside rail width of 37 inches measured at the fuel cell mounting location. The rear sub-frame rails must extend rearward from the main frame rails up and over the rear axle and down to the fuel cell mounting location then rearward to the rear crossmember. When rear sub-frame side rails do not connect directly to the main frame rails at the front of the sub-frame, right and left side connecting rails must be used between the inside vertical wall of the main frame rails and the rear sub-frame front side rails. The connecting rails must be constructed using two (2) inch or three (3) inch wide by four (4) inch high rectangular box tubing with a wall thickness of 1/8 inch meeting the ASTM A-500 specification. Connecting rails must be welded perpendicular to the inside vertical surface of the right and left side main frame rails and must be located flush with the top and bottom surfaces of the main frame rails. The material dimensions and mounting locations of the connecting rails must match on the left and right sides. The length of the right and left rear sub-frame rear side rails must be a minimum of 23 inches, measured along the top surface of the rail. The rear sub-frame rails above the rear axle housing and rear springs must be located a minimum of 22 inches and a maximum of 25 inches from the inspection surface to the bottom surface of the frame rail. The rear sub-frame rails above the rear axle housing and rear springs must measure a minimum of eight (8) inches in length, measured along the bottom horizontal surface of the sub-frame rail section.

A rear jacking bolt mounting crossmember must be welded to the inside vertical surface of the left and right rear sub-frame rail sections above the rear axle housing. The jacking bolt crossmember must be constructed from a single, straight, one (1) inch high by two (2) inches wide by 37 inches long rectangular box tube. Two

(2), cylindrical, threaded, jacking bolt mounting slugs must be welded through the crossmember at a location of 17-1/2 inches, on center, to the left and right of the vehicle's longitudinal centerline, and 42.8 inches on center, rearward from the rear vertical wall of the trailing arm crossmember. These slugs must be located vertical to the inspection surface and must not be adjustable in, or removable from, the crossmember. Rear jacking bolt "slugs" must be one (1) piece with complete threads through the rear jacking bolt crossmember. Rear jacking bolt "slugs" must be completely welded.

A rear shock absorber mounting crossmember must be welded to the top surface of the left side and right side rear sub-frame rail sections above the rear axle housing. (See Diagram #1A, in the rear pages of the Rule Book.)

Supports for the rear shock absorber crossmember will be limited to a maximum of one (1), maximum one (1) inch outside diameter by a maximum of 20 inches long, tubular support on each end of the crossmember.

The rear sub-frame must incorporate the mounting locations for the rear springs, shock absorbers, track bar, sway bar and fuel cell ending with a crossmember two (2) inches in width by three (3) inches in height with a minimum wall thickness of 0.075 inch meeting the ASTM A-500 specification. The rear sub-frame crossmember must be located eight (8) inches behind the fuel cell recessed well and at a height of 16-1/2 inches from the inspection surface to the bottom of the crossmember and the rear sub-frame rear side rails, as referenced in Diagrams #1A, B & C, in the rear pages of the Rule Book.

Other than the bottom support frame for the fuel cell recessed well, as described in sub-section 20C-16.3, unless otherwise authorized by ARCA Officials, nothing may be mounted lower than the bottom of the fuel cell recessed well behind the rear axle housing. The rear sub-frame rails must connect to the main frame rails not less than 57 inches from the front end of the main frame rails. At any point along the sub-frame rails, the distance to each sub-frame rail from the longitudinal centerline must be the same (see Diagram #1A, in the rear pages of the Rule Book).

D. The frame and roll cage assembly must be painted using only light/bright colors.

20C - 12 SUSPENSION

All suspension systems and components must be approved by ARCA. Each such part may thereafter be used until ARCA determines that such part is no longer eligible. All suspension fasteners and mounting hardware must be made of solid magnetic steel.

Rear Suspension

A. Only a two (2) link trailing arm-type rear suspension will be permitted. The rear suspension will be coil springs mounted on the trailing arms and must not be located outside the rear frame rail kick-ups and must be equal distance from the longitudinal centerline of the vehicle.

1. For all vehicles competing with a 110 inch wheelbase, mounting points on the axle housing must be evenly spaced, plus or minus (+/-) 1/2 inch and welded to the axle housing to prevent movement.
2. For all vehicles competing with a 105 inch wheelbase, mounting points on the axle housing must be evenly spaced and welded to the axle housing to prevent movement.

B. The front trailing arm mounting brackets must be one-piece, welded magnetic steel, not less than 3/16 inch thick. Both forward trailing arms must be attached to the trailing arm mounting brackets with one (1) solid one-piece minimum 3/4 inch diameter magnetic steel bolts. An eccentric-type adjuster may be used on only one (1) forward trailing arm mounting point. If used, the adjuster must be tack welded or fastened to the trailing arm bracket in a way that is acceptable to ARCA Officials to prevent movement during competition. Trailing arm mounting slugs may be used to locate the trailing arms on the trailing arm mounting brackets. The maximum distance between the front trailing arm mounts must not exceed 12-1/2 inches, measured center to center at the trailing arm front monoball assemblies. When the trailing arms are attached to the front trailing arm mounting brackets, the horizontal centerline of each trailing arm mounting bolt must be within four (4) inches in height of the opposite trailing arm mounting bolt when measured vertically. Hydraulic or spring loaded mounting points or links will not be permitted.

As a mounting option, ARCA-approved bolt-on trailing arm mounting brackets may be used. The horizontal centerline of the highest trailing arm mounting bolt holes must not be higher than the top of the trailing arm crossmember (10-5/16 inches) at the location of the trailing arm mounting bracket.

C. Trailing arms must use a monoball assembly and the assembly must be used to locate and secure the trailing arm to the trailing arm mounting bracket. A single, cylindrical monoball sleeve must be installed on the longitudinal centerline of the left and right side trailing arms. The monoball sleeves must be completely welded to the trailing arms. The inside of the monoball sleeve must create a pressed fit to the outside diameter of the installed monoball assembly. The monoball assembly must be installed in the center of the monoball sleeve. Movement in any direction, beyond the normal pivoting of the monoball, will not be permitted. Top hats and/or spacers must be used to locate and restrict lateral movement of the trailing arms between

the trailing arm mounting brackets.

D. Trailing arms when measured from the center of the front mounting bolt hole to the center of the rear axle locating pin, in a straight line, must maintain a length of 51 inches on one side. The opposite side trailing arm must not be more than 51 inches and not less than 45 inches in length. All trailing arms must rise at a single angle, a minimum of eight (8) degrees and a maximum of 16 degrees, at the center of the rear axle tube when compared to the forward length of the trailing arm.

E. I-Beam style trailing arms must be welded on the top and bottom with a 1/2 inch minimum stitch weld every eight (8) inches maximum along the entire length of the trailing arm. Trailing arms must be constructed using two (2) C-channels of a minimum of (1) inch in width by three (3) inches in height magnetic steel with a minimum nominal wall thickness of 1/8 inch meeting the ASTM A-569 specification, welded back to back, creating a vertical wall of two (2), 1/8 inch wall thicknesses with a completed overall size of two (2) inches minimum and 2-1/4 inches maximum in width by three (3) inches in height. The minimum thickness of trailing arm material that will be accepted by ARCA Officials is 0.117 inch. Each C-channel (meeting the ASTM standard C-channel shape) must have a three (3) inch vertical wall with a one (1) inch upper and lower horizontal lip folded at a 90 degree angle to the vertical wall using a maximum of 1/4 inch bend radius. Two (2), maximum 13/16 inch inside diameter, steel tubes must be installed on the longitudinal centerline of the arm at the U-bolt mounting location. The tubes are a welded component of the arm assembly and must be completely welded to both halves of the arm. The trailing arms may be vertically reinforced from the rear of the lower coil spring mounting pad rearward. The height of the front trailing arm may be tapered from the trailing arm monoball assembly rearward but the taper must not exceed six (6) inches in length.

F. All trailing arms must be attached to the rear axle housing using solid, round 3/4 inch outside diameter U-bolts over the rear axle housing and through the trailing arms with nuts securing the trailing arms to the rear axle housing. Each U-bolt threaded end must have only one (1) standard 3/4 inch hex nut and only one (1), SAE flat washer. Jam (double) nuts and beveled washers will not be permitted on the U-bolts. Trailing arm U-bolt retainers must be adequately tightened as defined by industry standard torque recommendations for a 3/4 inch diameter fine threaded fastener.

G. Any spacers used between the rear axle housing and the trailing arms must be made of a solid metal block. Any device(s) that will permit movement or rotation of the rear end housing will not be permitted.

H. Trailing arms and mounting brackets must be acceptable to ARCA Officials. Holes and/or other modifications to the trailing arms and mounting brackets that, in the judgment of ARCA Officials, have been made with the intent of weight reduction or weight addition will not be permitted.

I. The rear axle housing must be held in the center of the vehicle, side to side, by a single, straight, round, tubular magnetic steel track bar with a maximum outside diameter of 1-1/4 inches for the entire length of the track bar. The track bar must use a 3/4 inch, heavy-duty, heim joint (spherical rod end) or approved rod end at each end to attach to the trailing arm and frame mounts. The track bar must be a minimum length of 40 inches connected to the rear end of the left side trailing arm and to a bracket welded to the frame rail on the right side. The track bar mounting bolt at the trailing arm must include a 1/8 inch thick magnetic steel washer with an outside diameter larger than the body of the heim joint (spherical rod end). The track bar mounting bolt, at each end of the track bar, must be magnetic steel and a minimum of 5/8 inch diameter. A metal spacer will be permitted between the track bar mount on the trailing arm to the heim joint (spherical rod end) ball. The distance from the track bar mount on the trailing arm to the heim joint (spherical rod end) must not be more than 1-1/2 inches. Variable height adjustments to the track bar must be made by means of a movable threaded-screw bracket and must be made from the frame mount side only. The frame side track bar mounting bolt must extend through the front and rear of the track bar bracket and track bar to create a positive stop. The upper adjustment to the threaded-screw bracket (located just under the rear window) must share the same vertical centerline with the threaded-screw bracket. The trailing arm side of the track bar, track bar brackets and/or components must not be lower than the lowest edge of the respective rear wheel. The frame side track bar mounting bracket and components must have a minimum of 5-1/2 inches of ground clearance. The measurement will be checked with the tires inflated to the recommended technical inspection inflation pressures for the Event.

J. At road course Events, the track bar mounting configuration may be reversed except when the NASCAR-approved (Generation 5) frame and roll cage assembly is used.

20C - 12.1 Coil Springs / Spring Mounts / Jacking Bolts

Only coil spring suspension will be permitted. All coil springs must be constructed using solid, round magnetic steel wire, wound in a clockwise direction. Ovate and flat wire will not be permitted. The coil spring wire diameter must be the same size from the top to the bottom of the spring. All of the coils in a spring must be active. The coil springs at all four (4) wheels must be active and permit suspension

movement. All coil springs must not be colder than ambient temperature.

A. Front Coil Springs

1. The front coil springs must be heavy-duty magnetic steel and must be constructed with one (1) closed, ground coil end and one (1) open coil end. The closed end of the coil spring must not have a gap larger than 1/8 inch. Grinding of the open coil end will not be permitted beyond the first inch of the open coil end and must not exceed 1/2 of the coil spring wire diameter.
2. The minimum number of active coils for each spring must be 4-1/2 coils. Coil count and spacing will be referenced on a line perpendicular to the closed end of the coil spring at the end of the spring wire of the closed end of the coil spring. All coils must be evenly spaced after the first coil on the closed end of the spring and remain even to the completion of the 4th full coil. Additional coils (more than 4-1/2) will be permitted providing the additional coils are active, the coil spring meets the free height requirements (see sub-section 20C-1A(3), below) and the gap at the end of the coil spring wire at the open end of the coil spring is larger than 1/8 inch. All coils must be wound producing the same inside and outside coil diameter plus or minus (+/-) 1/8 inch.
3. The free height of the bare front coil springs must not be more than 11 inches and must not be less than 7-1/2 inches.
4. All front coil springs must maintain a minimum outside diameter of five (5) inches and a maximum outside diameter of 5-3/4 inches.
5. Progressive or digressive rate springs will not be permitted.
6. Coil springs may be coated but coating thickness and material must be acceptable to ARCA Officials.
7. Coil spring rubber inserts not to exceed one (1) full coil of the front coil spring at any time, acceptable to ARCA Officials, will be permitted. Coil spring rubber inserts must not be less than 1/2 of a full coil.
8. ARCA-approved coil spring wire wraps may be used on the front coil springs. Coil spring wire wraps must be installed on active coils only.
9. The front coil spring mounts must be located on the lower A-frames for the bottom mount, and the top mount must be a bucket-type and be welded to the front sub-frame rails. The front coil spring upper mount plate must be attached to the front jacking bolt, in a manner acceptable to ARCA Officials. Monoball(s), excessive taper, bevels, or other devices on the end of the front jacking bolt or in the front upper spring mount plate will not be permitted. The upper coil spring mount plate must support the front coil spring for 360 degrees. The lower coil of the front coil spring must be in contact for 270 degrees with the lower spring seat at all times.
10. Heavy-duty solid magnetic steel bolts (jacking bolts), with a minimum diameter of 1-1/8 inch, utilizing right-hand threads, and a single thread count of not less than 12 threads per inch for the entire length of the jacking bolt, must be used. The jacking bolts must be installed, using a solid threaded sleeve either welded or bolted with a minimum of four (4), 5/16 inch diameter grade-8 bolts and nuts or threaded into the frame spring bucket, in a manner acceptable to ARCA Officials for the purpose of raising or lowering the vehicle. Jacking bolts and the threaded sleeves must be the same thread configuration on the left and right side.

B. Rear Coil Springs

1. The rear coil springs must be heavy-duty magnetic steel and must be constructed with both coil ends closed and ground. The closed ends of the coil spring must not have a gap larger than 1/8 inch.
2. The maximum number of coils for each rear coil spring must not exceed 10 coils. All coils must be evenly spaced between the top and bottom closed ends of the spring. Coil count will be referenced on a line perpendicular to either closed end of the coil spring at the end of the spring wire. All coils must be wound producing the same inside and outside diameter.
3. The free height of the bare rear coil springs must not be greater than 16 inches and must not be less than 11 inches.
4. All rear coil springs must maintain a minimum outside diameter of 4-3/4 inches and a maximum outside diameter of 5-1/4 inches.
5. Progressive or digressive rate springs will not be permitted.
6. Coil springs may be coated but coating thickness and material must be acceptable to ARCA Officials.
7. Coil spring rubber inserts not to exceed two (2) full coils of the rear coil spring at any time, acceptable to ARCA Officials, will be permitted. Coil spring rubber inserts must not be less than 1/2 of a full coil.
8. Coil spring wire wraps will not be permitted on rear coil springs.
9. All upper and lower rear coil spring mounts must be located between the rear sub-frame side rails. Only one (1) rear jacking bolt solid threaded mounting sleeve per side will be permitted. All rear jacking bolts and all

jacking bolt sleeves must be a minimum of one (1) inch diameter thread, utilize right-hand threads and a single thread count of not less than 12 threads per inch for the entire length of the jacking bolt and mounting sleeve. All rear jacking bolts must be made of magnetic steel. All jacking bolt mounting sleeves must be welded into the rear sub-frame assembly. Jacking bolts and the threaded sleeves must be the same thread configuration on the left and right side. Rear jacking bolts will not be permitted to extend through the frame rails. The jacking bolt crossmember must have a solid sleeve extending through the crossmember from top to bottom and be welded completely into the crossmember.

10. The rear coil spring lower mounts must be located on the trailing arms forward of the rear axle and must be centered on the trailing arm I-beam. A maximum distance of nine (9) inches will be permitted from the center of the rear spring to the center of the rear axle housing. The rear coil spring lower mounts must be located on the rear trailing arms directly below the upper rear coil spring mounts when viewed from the rear and the side of both mounts when the vehicle is on the ground at ride height. Jacking bolts, upper and lower spring mounts, and the spring must be on a common centerline perpendicular to the ground.
11. The rear coil spring upper mounts must be located and welded on the chassis directly above the lower mounts. The upper adjustment to the jacking bolts (located just under the rear window) must not be located further rearward than the center of the rear axle housing. The distance between the upper adjustment to the jacking bolts must be the same as the distance between the centers of the upper rear spring mounts.
12. Monoball(s), excessive taper, bevels or other devices on the end of the rear jacking bolt or in the rear upper spring mount will not be permitted.
13. Any device(s) such as chains, cables, etc. that limit the travel of the rear suspension either up or down will not be permitted. When jacking the vehicle, a minimum of one (1) inch of chassis movement is required before movement of the axle/tire assembly.

20C - 12.2 Sway Bars (Anti-Roll Bars)

Front and rear sway bars, when used must be used for the purpose of anti-roll only. Pre-loading of the sway bar(s) beyond the limits of the driver's weight in the driver's seat or on the left door top will not be permitted. The front and rear sway bars must freely rotate in their mounts. The movement of the front and rear sway bar arms must not be prevented or restricted beyond that of normal use as an anti-roll bar.

A. The main body of the front and rear sway bar must be made of one-piece magnetic steel.

B. The front sway bar (anti-roll bar) mounting tube must be a welded component of the front sub-frame assembly, mounted below the sub-frame rails, using a maximum of three (3) inch outside diameter round steel tubing.

C. The front sway bar arms must be constructed of magnetic steel and must not exceed a maximum of 1-1/8 inch in width. Only one (1), one-piece sway bar arm per side must be used on the front sway bar. Sway bar arms must be attached to the lower control A-frames. Heim joints (spherical rod ends) may be used for attaching the sway bar arms to the lower A-frames only. During qualifying and the Race, all upper and lower sway bar arm links must be attached to their respective mounting bracket using only positive nut and bolt mounting fasteners. Holes and/or other modifications that, in the judgment of ARCA Officials, have been made with the intent of weight reduction will not be permitted.

D. Rear sway bars will be permitted at road courses only. The rear sway bar, if used, must be mounted in a manner acceptable to ARCA Officials.

1. The rear sway bar must be mounted above the rear axle tubes.
2. Only one (1) one-piece sway bar arm per side must be used on the rear sway bar.
3. Heim joints (spherical rod ends) may be used on the rear sway bar connecting links.

20C - 12.3 Shock Absorbers

A. Shock absorbers and components must be from an approved manufacturer and must be acceptable to ARCA Officials.

B. All approved shock absorbers must be of the nitrogen-gas pressurized mono-tube, deflective disc valve type with an integral gas reservoir. Only gas state materials will be permitted to be used to fill the reservoir.

C. Shock absorber base valves will be permitted.

D. Shock absorbers must meet the following dimensions:

<u>PARAMETER</u>	<u>SPECIFICATION (inches)</u>
Overall Center-to-Center Length (Extended)	18:00 (minimum) – 24.75 (maximum)
Piston/Main Shock Absorber Body Outside Diameter	2:00 (maximum)
Piston/Main Shock Absorber Body Length	10.75 (maximum)
Shock Shaft Diameter	0.540 (minimum) – 0.630 (maximum)

E. The internal bore of the shock absorber body must remain as supplied by the manufacturer. The internal bore diameter of the shock absorber body must be the same from top to bottom. Tapers, steps, grooves and other misalignments will not be permitted. Modifications which provide position sensitive piston travel will not be permitted.

F. Internal bump stops will not be permitted. The shock absorber shaft must not have any sleeves, spacers, or devices inside the main shock absorber body that could limit the travel of the shaft into or out of the main shock absorber body.

G. Shock absorbers will be permitted to have only one (1) manual external adjustment.

- On low speed standard shock absorber shaft applications, a single manual external shaft bleed adjustment through a tapered needle into a fixed orifice in the hollow shaft will be permitted on the shock absorbers.
- On high speed shock absorber shaft applications, a single manual external adjustment that adjusts the pre-load of the applicable pressure relief mechanism will be permitted. This adjustment must only affect either the rebound force or the compression force, not both.

H. Changes in shock absorber force must not be made by the position of the shock absorber shaft, only by the velocity of the shaft through the compression and rebound stroke.

I. Only one (1) piston per shock with one (1) shim stack on compression side and one (1) shim stack on the rebound side of piston will be permitted.

J. Except for shortening of the main shock absorber body, modifications to the main shock absorber body will not be permitted. The main shock absorber body must remain the manufacturer's specified thickness.

K. Except for the removal of material on shock absorber shafts and metering rods, modifications to the shock absorber shaft will not be permitted.

L. At any time after being charged, the shock absorbers must fully compress and fully extend the entire length of the shock absorber shaft with the external adjustment set in any position.

M. During shock absorber inspection, the shock absorbers and the shock absorber fluid must not be less than the ambient temperature or more than 100 degrees Fahrenheit, determined by the ARCA temperature monitoring devices.

N. The front shock absorber nitrogen gas pressure must not be less than 25 PSI or greater than 300 PSI.

O. The rear shock absorber nitrogen gas pressure must not be less than 25 PSI or greater than 175 PSI.

P. A maximum of one (1) shock absorber per wheel will be permitted.

Q. Shock absorbers will not be permitted inside of the front or rear coil springs. Shock absorbers will not be permitted inside of the upper A-frames.

R. At all times during the Event (inspection, qualifying and the Race), all upper and lower shock absorber mounting eyelets must be attached to their respective mounting bracket using only positive nut and bolt mounting fasteners.

S. Shock absorbers must be mounted on the vehicle with the gas reservoir to the top.

T. Front shock absorber upper and lower mounts must be non-adjustable components.

U. Rear shock absorber upper mounts must be located inside the frame and the mounts must be non-adjustable components welded directly to the rear shock absorber crossmember.

V. Rear shock absorber lower mounts must be attached to the inside of the trailing arms rearward of the rear axle housing a maximum distance of two (2) inches when measured from the rear of the axle tube to the shock absorber shaft. The rear shock absorbers may not angle inboard towards the center of the vehicle more than 30 degrees from vertical.

W. It is the responsibility of the crew chief, not ARCA, to ensure the shock absorbers are used in accordance with the manufacturer's instructions and specifications.

20C -12.3.1 Travel Limiting Devices

A. Only one (1) travel limiting device, per front shock absorber, will be permitted.

B. Only one (1) magnetic steel coil spring, one (1) upper bump spring seat, one (1) lower bump spring seat, and additional packers may be added to the front shock

absorber shaft.

- C. The spring must not exceed a maximum outside diameter of 2.60 inches.
- D. Bump spring seats must be constructed of metal.
- E. Packers must be constructed of metal.
- F. The top and bottom surfaces of all packers must be parallel.
- G. One (1) jam nut spacer, constructed of metal, added to the front shock absorber external shaft will be permitted.
- H. Non-metallic bushings and/or o-rings may be used to prevent shock shaft wear. If used, they may only be added to the upper and lower bump spring seats.
- I. Jam nuts for front shock absorber eyelets may be modified or constructed by the Competitor to be used in conjunction with the travel limiting device.
- J. Pre-loading of the travel limiting device will not be permitted.
- K. Outer cups, covers, or heat shields will not be permitted. The spring must remain visible at all times.
- L. Any other device or procedure that is used as a travel limiter will not be permitted.

20C - 12.4 A-Frames

A. A-frames must have a stock appearance and be made of magnetic steel. All lower A-frames must be a one-piece welded assembly constructed of flat plate and rectangular box tubing. Holes and/or other modifications that, in the judgment of ARCA Officials, have been made with the intent of weight reduction or to increase the components weight beyond normal standards will not be permitted.

B. A metal, non-adjustable lower spring seat may be bolted inside the lower A-frame spring bucket using four (4), 5/16 inch diameter bolts. The bolts must be evenly spaced in the bottom of the lower A-frame spring bucket. Only four (4) bolt holes will be permitted in the lower A-frame spring bucket. Additional holes for "clocking" of the spring seat must be installed in the spring seat. The lower spring seat must have a minimum two (2) inch inside diameter hole, located on center, for inspection purposes. The lower coil of the front coil spring must be in contact for 270 degrees with the lower spring seat at all times.

C. The lower A-frames for all 110 inch wheelbase vehicles must be the same length, plus or minus (+/-) 1/2 inch, and mount in the approved position (i.e., left and right must agree; offsets will not be permitted).

D. The lower A-frames for all 105 inch wheelbase vehicles must be the same length and mount in the approved position (i.e., left and right must agree; offsets will not be permitted).

E. The minimum thickness of the lower A-frames must be 0.090 inch. Lower A-frames must be constructed with one (1) front bushing pivot and one (1) rear bushing pivot. Strut type lower A-frames will not be permitted.

F. Heim joints (spherical rod ends) will not be permitted on upper and lower A-frames.

G. The lower A-frames must attach to the chassis using two (2), minimum 1/2 inch diameter magnetic steel bolt and nut assemblies per side. Only one (1) non-adjustable lower A-frame mounting hole per side will be permitted.

H. Only one (1) eccentric per side on the lower A-frame mounting points will be permitted.

I. The upper A-frame cross-shafts must maintain a minimum diameter of 3/4 inch. The upper A-frames must attach to the chassis using two (2), minimum 1/2 inch diameter magnetic steel bolt and nut assemblies per side.

J. The upper A-frame tubing must be round and maintain a minimum outside diameter of one (1) inch and have a minimum thickness of 0.083 inch.

K. Ball joints must be heavy-duty magnetic steel construction and must be acceptable to ARCA Officials. The ball joints must not have any adjustment with the exception of a free play adjustment in the housing for the ball and socket.

20C - 12.5 Spindles / Wheel Bearings / Hubs

A. One-piece, non-adjustable, heavy-duty magnetic steel spindles must be used. Steering arms, if separate, must be bolted to the spindles using two (2) minimum 5/8 inch diameter, grade 8, magnetic steel bolts. Hollow or drilled spindles will not be permitted.

B. Offset spindles will not be permitted.

C. Hubs may be offset a maximum of 1/4 inch.

D. Only magnetic steel hubs acceptable to ARCA Officials will be permitted. Holes and/or other modifications that, in the judgment of ARCA Officials, are made or used with the intent of weight reduction will not be permitted.

E. The front spindles must be linked to the front sub-frame using two (2) Vectran HS V-12 fiber cables. One eye of the cables must loop over the upper portion of the spindle and must be secured, and the other eye must loop over either the upper or lower portion of the solid, magnetic steel jacking bolt, minimum diameter 1-1/8 inches, and be securely retained with a heavy-duty metal washer, minimum two (2) inches in diameter and minimum 1/8 inch thick steel, or minimum 1/4 inch thick aluminum, and a locking nut. The fiber cable must be constructed from a continuous loop of 5/16 inch diameter 12 strand cable (with a red tracer thread) woven from Vectran® HS V-12 fiber. Spindle tethers must be installed using the supplied nylon

thimble or a metal sleeve that prevents the spindle tether from coming in contact with the jacking bolt threads.

F. Wheel bearings must be magnetic steel, tapered roller bearings and bearing races. The bearings, races and seals must be assembled separately in the hubs.

20C - 12.6 Tread Width Requirements

A. When the ARCA-approved (Generation 4) frame and roll cage assembly is used, a minimum center to center front and rear tread width of 60-1/4 inches and a maximum tread width of 60-3/4 inches will be permitted. The tread width will be determined by measuring from the front left outside wheel bead surface to the front right outside wheel bead surface at spindle height. A minimum of 70 inches and a maximum of 70-1/2 inches must be maintained.

B. When the NASCAR-approved (Generation 5) frame and roll cage assembly is used, a minimum center to center front and rear tread width of 60-1/4 inches and a maximum tread width of 61-3/4 inches will be permitted. The tread width will be determined by measuring from the front left outside wheel bead surface to the front right outside wheel bead surface at spindle height. A minimum of 70 inches and a maximum of 71-1/2 inches must be maintained.

C. Only magnetic steel spacers, with a maximum outside diameter of seven (7) inches, acceptable to ARCA Officials, will be permitted between the brake rotor mounting hat and the wheel to adjust the tread width to within the specifications as stated above. When spacers are used, there may be a maximum difference in thickness of 1/2 inch between the left and right side, while maintaining the tread width as stated above, but the front and rear do not have to be the same thickness.

20C - 12.7 Wheelbase Requirements

A. All vehicles competing with a 110 inch wheelbase must measure the wheelbase as follows; one side measurement must be 110 inches. The opposite side wheelbase must measure a minimum of 109-1/2 inches and a maximum of 110-1/2 inches.

B. All vehicles competing with a 105 inch wheelbase must measure the wheelbase as follows; one side measurement must be 105 inches. The opposite side wheelbase must measure a minimum of 104-1/2 inches and a maximum of 105-1/2 inches. Any device or procedure which has the ability to dynamically change the wheelbase beyond normal travel parameters will not be permitted.

105 inch wheelbase vehicles are approved for competition at all ARCA West Series stand-alone Events on oval tracks less than 3/4 mile in length and road courses only.

Effective January 1, 2025, 105 inch wheelbase vehicles will be approved for competition at all ARCA West Series Road Course Events only.

Only the approved "Spec" and Built engines will be permitted for use with 105 inch wheelbase vehicles.

If the NASCAR-approved (Generation 5) frame and roll cage assembly is used, it must be used for 110 inch wheel base vehicles only.

20C - 12.8 Body Height / Ground Clearance Requirements

20C - 12.8.1 Body Height Requirements

A. All vehicles competing must maintain a minimum roof height of 54 inches and a maximum roof height of 55-1/2 inches. The vehicle height off the ground and the body height, including the rake or the degrees of body angle, shall be determined by measuring the overall height of the vehicle at the divot on the roof centerline. After competition, the minimum roof height permitted will be 53-3/4 inches and a maximum roof height of 55-3/4 inches.

B. Competitors presenting vehicles for inspection must have their tires inflated to the recommended technical inspection inflation pressures as specified by the participating tire manufacturer for the Event. If tire pressure(s) are not at the recommended technical inspection inflation pressures after competition, tires will be adjusted to the recommended technical inspection inflation pressure(s) as specified by the participating tire manufacturer for the Event.

C. The rear height will be measured with ARCA rear height gauges. Both the left side and right side must measure a minimum of 44 inches and a maximum of 44-1/2 inches. After competition, the minimum rear height permitted will be 43-3/4 inches and a maximum rear height of 44-3/4 inches. The gauges will contact the top surface of the rear spoiler 23 inches left and right of the deck lid centerline.

D. At road course Events, the height of the rear of the vehicle must be a minimum of 43-3/4 inches and a maximum of 44-3/4 inches on the left side and the right side. After competition, the minimum rear height permitted will be 43-1/2 inches and a maximum rear height of 45 inches. The gauges will contact the top surface of the rear spoiler 23 inches left and right of the deck lid centerline.

20C - 12.8.2 Ground Clearance Requirements

A. On all vehicles, except as provided in sub-section B below, the left side frame rail and rocker panel clearances must be a minimum of 4-3/4 inches and the right side frame rail clearance must be a minimum of six (6) inches measured at the end of the frame rail ahead of the right rear tire.

B. On all vehicles, for road course Events, the frame rail and rocker panel clearances on the highest side of the vehicle must be a minimum of six (6) inches when measured at the end of the frame rail ahead of the rear tire on that side. The lowest frame rail must have a minimum clearance of 4-3/4 inches.

C. The front air dam clearance must be a minimum of four (4) inches.

D. All suspension parts clearance must be a minimum of four (4) inches.

E. The oil pan clearance must be a minimum of three (3) inches.

F. The exhaust pipe clearance must be a minimum of three (3) inches.

G. The left side vertical extension clearance must be a minimum of three (3) inches and the right side vertical extension clearance must be a minimum of four (4) inches.

*At road course Events, the right side vertical clearance must be a minimum of three (3) inches.

H. The engine ground clearance from the center of the leading edge of the crankshaft accessory drive bolt must be a minimum of 10 inches and a maximum of 12 inches for all currently approved engines. Nothing may be located directly forward or below the front end of the crankshaft that would interfere with the engine ground clearance inspection.

20C - 12.9 Vehicle Height Adjustment / Handling Devices

A. The only device permitted for adjusting the height of a vehicle will be the front and rear jacking bolts, as described in sub-section 20C-12.1.A(9) and 20C-12.1B(8). Adjustments will be permitted during an Event but must be done in a manner that results in the vehicle maintaining body height requirements, as described in sub-sections 20C-12.8.1.

B. Any device(s) for adjusting the handling characteristics or the vehicle's height, which can be activated by the driver, will not be permitted inside of the driver's compartment.

C. Electrical, pneumatic, hydraulic, remote control, or any other devices that change the handling characteristics or height of the vehicle will not be permitted.

D. Devices and/or procedures to, or used to, reduce or hold the vehicle lower than the normal stiffness of the springs will not be permitted.

20C - 13 STEERING COMPONENTS

All steering components must be approved by ARCA. Each such part may thereafter be used until ARCA determines that such part is no longer eligible.

A. Steering wheels must have three (3) solid magnetic steel spokes securely attached to a magnetic steel rim structure.

B. The center-top of the steering post must be padded with at least two (2) inches of resilient material acceptable to ARCA Officials.

C. A quick release steering wheel coupling with a housing must be used. The quick release steering wheel coupling may be constructed of aluminum; the housing must be constructed of magnetic steel. Three magnetic steel bolts must be used to secure the steering wheel to the quick release steering wheel coupling. The steering wheel coupling must meet the SFI 42.1 specification and display a valid SFI 42.1 label on the outside surface.

D. All vehicles must be equipped with a magnetic steel steering shaft with a collapsible section acceptable to ARCA Officials.

E. The steering shaft, forward of the firewall, must have a minimum of two (2) universal joints or a collapsible steering shaft. The use of universal joints in the steering shaft must be acceptable to ARCA Officials.

F. Rack and pinion steering will not be permitted.

G. Hydraulic power assist steering will be permitted. The power steering pressure pump must be mounted on the front of the engine and must be engine driven through a V-type or flat type V-ribbed belt.

H. The steering box must be constructed of magnetic cast steel and approved by ARCA. The Delphi (formerly Saginaw) type 600 and 700 Series steering boxes are the only currently approved steering boxes.

I. Tie rods, drag links and steering component parts must be solid, heavy-duty magnetic steel. The tie rod ends must not have any adjustment with the exception of a free play adjustment in the housing for the ball and socket. Holes and/or other modifications in steering components that, in the judgment of ARCA Officials, have been made with the intent of weight reduction will not be permitted.

J. The tie rod adjusting sleeve must not be more than five (5) inches in length. Heim joints (spherical rod ends) will not be permitted on any steering linkage.

20C - 14 BRAKES / BRAKE COOLING

All brakes and brake cooling components must be approved by ARCA. Each such part may thereafter be used until ARCA determines that such part is no longer eligible.

Holes and/or other modifications in the braking system or components that, in

the judgment of ARCA Officials, have been made with the intent of weight reduction will not be permitted.

20C - 14.1 Brake Components

A. Only disc brakes with magnetic cast iron or cast steel round rotors using aluminum mounting hats will be permitted. All mounting hats must be installed over the outside of the hub between the wheel and the hub. Only metal brake calipers will be permitted. Each brake caliper mounting bracket must mount solid to the rear axle housing or front spindle.

B. Brakes must be operational on all four (4) wheels at all times.

C. Only one (1) brake caliper per wheel using only two (2) brake pads per caliper will be permitted.

D. Brake calipers must be acceptable to ARCA Officials. A complete list of approved brake calipers may be obtained by contacting the NASCAR R&D Center in Concord, North Carolina. ARCA Officials may use a brake caliper provided by the respective manufacturer as a guide in determining whether a Competitor's brake caliper conforms to the specifications of the Rule Book.

E. A maximum of six (6) pistons will be permitted in all front brake caliper assemblies. A maximum of four (4) pistons will be permitted in all rear brake caliper assemblies.

F. Floating calipers will not be permitted.

G. Brake pads must have a magnetic steel backing plate.

H. Front brake rotors must be a minimum thickness of one (1) inch. Rear brake rotors must be a minimum thickness of 5/8 inch.

I. Master cylinders must be metal and must be mounted on the front side of the brake and clutch pedal mounting assembly above the steering column. Remote brake and clutch fluid reservoirs or master cylinders with integral fluid reservoirs must be mounted on the engine side of the vertical front firewall.

J. Overhead metal brake and clutch pedals must be mounted above the steering column and must be foot operated only. Brake pedal arms constructed of aluminum will not be permitted.

K. Only mechanical, hand operated, cable driven brake bias adjustment systems will be permitted.

L. In-line brake pressure proportioning systems and their location, acceptable to ARCA Officials, will be permitted. In-line brake pressure proportioning systems will not be permitted inside the driver's compartment. Electronic or remote control devices will not be permitted.

M. Electronic wheel speed sensors or brake actuators will not be permitted.

N. Quick disconnect fittings on the brake lines will not be permitted.

20C - 14.2 Brake Cooling

A. On all vehicles, all air used for front brake cooling must enter through the front of the vertical air dam wall above the valance and below the front bumper. Only a maximum of three (3) approved, maximum four (4) inch diameter, round air inlets which connect to a maximum of three (3), four (4) inch diameter flexible hoses on the back side of the vertical air dam will be permitted. The round air inlets must be mounted in the vertical air dam wall at a minimum distance of 14-1/2 inches from the vehicle's longitudinal centerline. One (1) in-line fan will be permitted to be used in each cooling hose. All brake cooling hoses must have one end mounted flush to the inside of the vertical air dam and the opposite end must be mounted a minimum of four (4) inches from the brake assembly for each wheel. Mounting of brake cooling components must be acceptable to ARCA Officials.

B. Brake fluid may be cooled by re-circulating the fluid through the brake hydraulic system.

C. Liquid or gas cooling of the brakes will not be permitted.

D. A maximum of two (2), three (3) inch diameter cooling hoses per rear brake will be permitted. The brake cooling hoses must be mounted with one end going to the rear brake assembly. One (1) in-line fan per hose may be used. The in-line fans must be mounted to supply air drawn from outside the driver's compartment. All in-line fans and hoses must not be mounted lower than the bottom of the rear trailing arms. Air scoops will not be permitted. The mounting of rear brake cooling components must be acceptable to ARCA Officials.

20C - 15 FUEL

ARCA reserves the right to have all vehicles use the same brand of fuel in a given Event. When this right is exercised, it will be stated on the Official Entry Blank or in other ARCA bulletins for that Event, and the specific brand of fuel will be named the "Official Fuel". In all such cases, fuel used for practice, qualifying, and the Race itself will be supplied at the track by the "Official Fuel" supplier and must be used exactly as supplied by the "Official Fuel" supplier's dispensing equipment at the track. At an Event where an "Official Fuel" has been named, ARCA Officials will use a sample of the actual fuel provided at the track by the fuel supplier to determine whether the fuel used by a Competitor conforms to the specifications in the Rule Book.

20C - 15.1 Definition

In the event there is no "Official Fuel" at a given Event, the term "Fuel" wherever used in this document, shall be understood to mean automotive gasoline that complies with the specifications given in sub-section 20C-15.2. ARCA Officials will use a sample of the actual fuel(s) provided at the track by the fuel supplier(s) to determine whether the fuel used by a Competitor conforms to the specifications in the Rule Book.

20C - 15.2 Specifications

- A. The fuel must be automotive gasoline only.
- B. The gasoline must comply with ASTM D-4814 entitled "Standard Specification for Automotive Spark-Ignition Engine Fuel", except limited to liquid hydrocarbons only, Class A, B, C, D, or E, but without regard to geographical or seasonal limitation.
- C. The gasoline must not be blended with alcohols, ethers or other oxygenates, and it must not be blended with aniline or its derivatives, nitro compounds or other nitrogen containing compounds.
- D. Icing or cooling of fuel will not be permitted during the Event in the garage, pit or racing premises.

20C - 15.3 Fuel Samples

ARCA has the right to sample a Competitor's fuel at any time during the Event. Samples will be impounded for observation and/or testing by ARCA and/or any outside laboratories at ARCA's discretion.

20C - 16 FUEL SYSTEM

All fuel systems and fuel system components must be approved by ARCA. Each such part may thereafter be used until ARCA determines that such part is no longer eligible.

- A. ARCA Officials will not permit the use of any previously approved fuel cells, containers, or check valves that appear to be damaged, defective, or do not function properly. Fuel cell vent pipe check valves must be used. Check valves and the fuel cell must be acceptable to Officials.
- B. Pressure systems will not be permitted. Any concealed pressure type containers, feed lines, or actuating mechanisms will not be permitted, even if inoperable. Icing, freon type chemicals or refrigerants must not be used in or near the fuel system.

20C - 16.1 Fuel Cell

A. Only the following fuel cell bladders are approved by ARCA for use in competition:

Aero Tec Laboratories, Inc. (ATL)	Aircraft Rubber Manufacturing, Inc.
FB 222 D	(FUEL SAFE)
FB 222 E	RB 122 E
FB 322 D	RB 122 E-L
FB 522 D	RB 022 E
FB 518	NASCOT 5B

Schultz Engineered Products (Schultz Fuel Cells)	Waterman Racing Components
STB22D	(WRC)
	NAS-220
	NAS-000

- B. Modifications to the approved fuel cell bladders, including the nut ring, will not be permitted.
- C. Standard foam, acceptable to ARCA Officials and used as provided by an approved fuel cell manufacturer, must be used.
- D. All approved fuel cells must be equipped with an approved fuel cell check valve assembly that meets one of the following minimum requirements:

FUEL CELL CHECK VALVE ASSEMBLIES
(STEEL BALL TYPE)

1. The fuel cell check valve housing must be manufactured of aluminum or magnetic steel plate not less than 1/4 inch thick. A cast aluminum check valve housing assembly will not be permitted. The bottom surface of the check valve plate must be flat. Spacers will not be permitted between the check valve plate and the fuel cell bladder. Only one (1) gasket with a maximum thickness of 0.065 inch will be permitted between the check valve plate and the fuel cell container.
2. The solid steel ball check valve must be encased in a four (4) rail carriage. The carriage rails must be constructed of solid aluminum or magnetic steel not less than 1/4 inch thick by not less than 3/4 inch wide material. The carriage rails must be positioned such that the surface of the 1/4 inch thick edge rides against the steel check ball. Outside surfaces of the carriage must not have any sharp edges. The carriage must not be altered in any

way and must remain perpendicular to the fuel check valve top flange plate.

3. The fuel filler check valve carriage must not exceed a maximum depth of 8-1/2 inches. The maximum inside diameter of the filler neck including the check ball seat must not exceed 2-1/8 inches. When seated, at least 1/2 of the check ball must be visible. The diameter of the solid steel check ball must be 2-3/8 inches. The filler neck must not be made of cast aluminum.
4. The fuel vent check valve carriage must not exceed a maximum depth of 8-1/2 inches. The maximum inside diameter of the vent pipe neck including the check ball seat must not exceed 1-1/4 inches. When seated, at least 1/2 of the check ball must be visible. The diameter of the solid steel check ball must be 1-3/8 inches. The fuel vent check valve neck must not be made of cast aluminum.
5. The fuel inlet tube and vent tube must have a bead around its outside circumference for hose retention.

(FLAP TYPE)

1. The fuel cell check valve housing must be from an approved manufacturer and be made of aluminum or magnetic steel plate not less than 3/16 inch thick. A cast aluminum check valve housing assembly will not be permitted. The bottom surface of the check valve plate must be flat. Spacers will not be permitted between the check valve plate and the fuel cell bladder. Only one (1) gasket with a maximum thickness of 0.065 inch will be permitted between the check valve plate and the fuel cell container.
2. The fuel filler check valve assembly equipped with a fuel resistant flap (Viton) mounted in the center of its circumference and must maintain a minimum outside diameter of 3-1/2 inches. The maximum inside diameter of the fuel filler inlet must not exceed 2-1/8 inches. The fuel filler check valve assembly must not be made of cast aluminum.
3. The fuel vent check valve carriage must not exceed a maximum depth of four (4) inches. The maximum inside diameter of the vent pipe neck including the check ball seat must not exceed 1-1/4 inches. The diameter of the solid steel ball/poppet must be 1-3/8 inches. The fuel vent check valve neck must not be made of cast aluminum.
4. The fuel inlet tube and vent tube must have a bead around its circumference for hose retention.

(ALUMINUM PADDLE FLAP TYPE)

1. The fuel cell check valve assembly must be from an approved manufacturer and meet the SFI 32.2 specification and display a valid SFI 32.2 label. Only the following fuel cell check valve assemblies are approved for competition:

<u>MANUFACTURER</u>	<u>PART NUMBER</u>
CV PRODUCTS	SPIN-EFI-1400
FUEL SAFE	NASCOT-5P1
FUEL SAFE	NASCOT-5P2
WATERMAN	NAS-007

2. The fuel cell check valve plate must be constructed of aluminum with a maximum nominal thickness of 1/4 inch. The bottom surface of the fuel cell check valve plate must remain flat. Spacers will not be permitted between the check valve plate and the fuel cell bladder. Only one (1) gasket with a maximum thickness of 0.065 inch will be permitted between the check valve plate and the fuel cell container.
3. The fuel cell filler check valve must be a spring loaded, metal, paddle type and must remain closed in any position except when refueling the vehicle.
4. The fuel cell filler hose neck must be constructed of aluminum. The fuel cell filler hose neck must be a curved shape with a reinforcing gusset in the bend radius. The fuel cell filler hose neck must have a maximum inside diameter of 2.125 inches and a maximum outside diameter of 2.500 inches.
5. The fuel cell vent check valve must be a spring-assisted, magnetic steel "bullet" poppet type valve.
6. The fuel cell vent hose neck must be straight, with a maximum height of 2.500 inches above the fuel cell check valve plate. The fuel cell vent hose neck must have a maximum inside diameter of 1.250 inches and a maximum outside diameter of 1.500 inches.
7. The fuel cell filler neck and vent hose neck must have a bead around its circumference for hose retention.

E. For road course Events, ARCA Officials may require the complete check valve assembly, be installed to accommodate a right side fuel filler.

F. Fuel cells must not be used beyond five (5) years after the date of manufacture.

20C - 16.2 Fuel Cell Container

The fuel cell container must be acceptable to ARCA Officials.

A. The fuel cell must be encased in a container of not less than 0.031 inch thick magnetic sheet steel.

B. The fuel cell may be encased in a container with a bolt-in end panel or a seamless container without removable panels.

1. If the fuel cell container has a bolt-in end panel, it must be fastened together with minimum 10/32 inch diameter bolts spaced a maximum of four (4) inches apart.
2. If the fuel cell container is a seamless container, it must not be less than 0.037 inch thick magnetic sheet steel of welded construction to form a seamless box without removable panels. Only a single opening will be permitted in the container. Such opening must be located at the center of the top of the container, must include the bolt pattern for the fuel cell bladder, and must not be larger than necessary for insertion and fastening of the fuel cell bladder.

C. The outside dimensions for the fuel cell container size must be one of the following:

22 Gallon Fuel Cell

33 inches in width by 17 inches in depth by 9-1/4 inches in height.

18 Gallon Fuel Cell

33 inches in width by 17 inches in depth by 8 inches in height.

D. Handles must be attached at the top of each end in the center of the fuel cell container for removal from the recessed well. Handles must not interfere with the ARCA inspection gauge.

E. Holes in the fuel cell container will not be permitted except for two (2) 1/8 inch drain holes in the bottom of the fuel cell container.

F. The fuel cell container must be coated bright red.

20C - 16.3 Fuel Cell / Fuel Cell Container Installation

The fuel cell and the fuel cell container must be installed in a manner acceptable to ARCA Officials.

A. The fuel cell and the fuel cell container must be installed in a recessed well of not less than 0.031 inch thick magnetic sheet steel welded to the trunk floor. The recessed well must be a minimum of 34 inches and a maximum of 37 inches in length, when measured from the left vertical wall to the right vertical wall. The vertical corners from top to bottom and the horizontal corners from front to rear of the recessed well should be reinforced using a one (1) inch by one (1) inch, 0.062 inch thick corner reinforcement, or the complete recessed well end cap, welded to the outside of the recessed well. The vertical walls of the fuel cell recessed well must be at 90 degrees to the fuel cell recessed well floor without any offset seams to interfere with the installation of, or create a void between, the wall of the fuel cell recessed well and the fuel cell container. The fuel cell recessed well, when measured from the bottom must be a minimum height of eight (8) inches. The fuel cell recessed well height will be measured with tire air pressures set at the tire manufacturer's recommended technical inspection inflation pressures for the Event. When installed in the fuel cell recessed well, the fuel cell container must be centered in the fuel cell recessed well. When installed in the fuel cell recessed well, each end of the fuel cell container must have honeycomb aluminum spacers installed between the fuel cell container and the fuel cell recessed well. The right and left spacers must be equal in thickness. All aluminum honeycomb spacers must be constructed using a minimum of 0.023 inch thick aluminum skins sandwiching a 1/2 inch cell, 60 psi strength minimum, aluminum honeycomb core. Filler panels must be constructed of clear solid (no holes) polycarbonate sheets.

B. The fuel cell and the fuel cell container must be installed as far forward as possible in the trunk compartment with equal distance between the frame rails. The fuel cell container must maintain the same height on all four (4) corners. When the fuel cell container is installed in the recessed well, the top of the fuel cell container must not be lower than the top of the rear sub-frame side rails and the rear sub-frame crossmember.

C. The fuel cell container, installed in the recessed well, must be secured on the top by a flat fuel cell top rack made of one (1) inch by one (1) inch by 0.065 inch minimum thick square magnetic steel tubing meeting the ASTM A-513 specification, bolted without removable spacers to the rear sub-frame rails and the front and rear fuel cell crossmembers or brackets welded to the rear sub-frame rails or the fuel cell crossmembers. The flat fuel cell top rack must consist of two (2) tubes lengthwise and two (2) tubes crosswise centered in the area from the fuel cell fill plate to the outside of the fuel cell container across the top of the fuel cell container. The flat fuel cell top rack must be attached using eight (8) minimum 5/16 inch diameter magnetic steel mounting bolts tightened to a minimum of 20 foot pounds. All fuel cell top rack mounting bolts must pass vertically through the top rack and be secured to the rear sub-frame or the fuel cell mounting crossmembers. When upright stands are needed to fill the space between the rear sub-frame rails, mounting spacers, or the fuel cell crossmembers and the flat fuel cell top rack, these upright stands must be completely welded to the sub-frame rails, mounting spacers, or the fuel cell mounting crossmembers. The flat fuel cell top rack must not be located more than 9-1/4 inches above the floor of the recessed well.

D. The front and rear fuel cell crossmembers must be constructed using one (1) inch wide by three (3) inches in height by 0.065 inch minimum thick magnetic steel tubing meeting the ASTM A-500 specification. The front and rear fuel cell crossmembers must remain straight and 90 degrees to the rear sub-frame rails.

E. The bottom support frame must be constructed using three (3) tubes, one (1) inch by one (1) inch by 0.065 inch minimum thick square magnetic steel tubing meeting the ASTM A-513 specification, equally spaced (and should be 9-1/2 inches center to center) across the recessed well. These tubes must be completely welded to the fuel cell front and rear crossmembers. The bottom of the fuel cell recessed well must be stitch welded to both sides of each one (1) inch by one (1) inch vertical and horizontal support frame tube. The support tubes must extend down the front and rear, and under the fuel cell container recessed well and must be located according to the construction guidelines at the rear of the Rule Book (refer to the Construction Guidelines at the rear of the Rule Book).

F. Holes in the fuel cell recessed well will not be permitted except for four (4) maximum 1/2 inch diameter drain holes in the corners of the floor of the recessed well.

G. A rear firewall (including any removable panels or access doors) of magnetic sheet steel not less than 0.027 inch thick must be located between the trunk area and the driver's compartment and must be welded in place. (refer to sub-section 20C-3.4B & C). The rear firewall, as viewed from left to right, must be straight and flat between the rear sub-frame rails. Removable panels and access doors must be sealed at all times during competition.

When the NASCAR-approved (Generation 5) frame and roll cage assembly is used it must meet the following specifications. Modifications to any of the specifications or components will not be permitted.

Fuel Cell / Fuel Cell Container Installation

The fuel cell and the fuel cell container must be installed on the frame's longitudinal centerline in a manner acceptable to ARCA Officials and in accordance with the following requirements:

A. The fuel cell and the fuel cell container must be installed in a recessed well constructed of magnetic sheet steel with a minimum thickness of 0.055 inch welded to the rear sub-frame side rails and the front and rear fuel cell crossmembers. The recessed well must be 37 inches wide, when measured from the left vertical wall to the right vertical wall, and 18 inches in length when measuring from the front vertical wall to the rear vertical wall. The vertical walls of the fuel cell recessed well must be at 90 degrees to the fuel cell recessed well floor without any offset seams to interfere with the installation of, or create a void between, the wall of the fuel cell recessed well and the fuel cell container. The fuel cell recessed well, when measured from the bottom must be a minimum height of 11 inches. The fuel cell recessed well height will be measured with tire air pressures set at the tire manufacturers recommended technical inspection inflation pressures for the Event. The fuel cell recessed well must be located 60.9 inches rearward of the trailing arm crossmember (see Diagram #1A, in the rear pages of the Rule Book). Beginning November 1, 2011, all new chassis must meet the following requirements: The "X" distance measurement to the forward, inside vertical surface of the fuel cell recessed well must be equal when comparing the left side to the right side, plus or minus (+/-) 0.125 inch. This measurement will be taken at the intersection of the floor and the forward inside vertical surface of the fuel cell recessed well, at a "Y" location of plus or minus (+/-) 17-1/2 inches from the chassis longitudinal centerline. Once the location of the recessed well has been verified, it must not be moved, altered, or modified.

B. The floor of the fuel cell recessed well must always remain parallel to the rear sub-frame rear side rails and rear sub-frame rear crossmember. When the fuel cell container is installed in the recessed well, the horizontal centerline of the rear sub-frame side rails and rear sub-frame rear crossmember must be in line with the horizontal centerline of the fuel cell container.

C. The fuel cell container, installed in the recessed well, must be secured on the top by a flat fuel cell top rack constructed of one (1) inch square magnetic steel tubing with a minimum wall thickness of 0.065 inch, meeting the ASTM A-513 specification, bolted to the rear sub-frame side rails and the front and rear fuel cell crossmembers. The flat fuel cell top rack must consist of two (2) tubes lengthwise, and two (2) tubes crosswise centered in the area from the fuel cell fill plate to the outside of the fuel cell container across the top of the fuel cell container. The flat fuel cell top rack must be attached using eight (8) minimum 5/16 inch diameter magnetic steel mounting bolts tightened to a minimum of 20 foot pounds. All fuel cell top rack mounting bolts must pass vertically through a maximum 3/8 inch inside diameter sleeve insert which has been completely welded for the full circumference of the sleeve to the top and bottom surface of the one (1) inch by one (1) inch fuel cell top rack at each mounting location. Removable spacers will not be permitted between the fuel cell top rack and its mounting locations. The eight (8) fuel cell top rack mounting bolts must be secured to the rear sub-frame or the fuel cell mounting crossmembers. When upright stands are needed to fill the space between the rear sub-frame rails or the fuel cell crossmembers and the flat fuel cell top rack, these upright stands must be completely welded to the sub-frame rails and/or the fuel cell mounting crossmembers. Fuel cell top rack mounting stands must be constructed of one (1) inch square magnetic steel tubing with a minimum wall thickness of 0.065 inch, meeting the ASTM A-513 specification. The flat fuel cell top rack must not be

located more than 9-1/4 inches above the floor of the recessed well.

D. When installed in the recessed well, the forward vertical side of the fuel cell container must have a 7-3/4 inches in height by 33 inches in length by 3/4 inch thick minimum honeycomb aluminum spacer installed between the fuel cell container and the fuel cell recessed well. When installed in the fuel cell recessed well, each end of the fuel cell container must have honeycomb aluminum spacers installed between the fuel cell container and the fuel cell recessed well. The honeycomb aluminum spacers must be 7-3/4 inches in height by 18 inches in length, with a single or combined thickness of 1-1/2 inches. A maximum of two (2) honeycomb aluminum spacers for each end may be used, and must be equal in thickness right and left, to center the fuel cell container in the fuel cell recessed well. All aluminum honeycomb spacers must be constructed using a minimum of 0.023 inch thick aluminum skins sandwiching a 1/2 inch cell, 60 psi strength minimum, aluminum honeycomb core. Spacers or filler panels, between the fuel cell container and the fuel cell recessed well, must be constructed of clear solid (no holes) polycarbonate sheets.

E. Holes in the fuel cell recessed well will not be permitted except for four (4) maximum 1/2 inch diameter drain holes in the corners of the floor of the recessed well.

F. The front and rear fuel cell crossmembers must be constructed of one (1) inch wide by three (3) inches high magnetic steel box tubing with a minimum wall thickness of 0.059 inch and a maximum wall thickness of 0.083 inch, meeting the ASTM A-500 specification. The front and rear fuel cell crossmembers must remain straight and 90 degrees to the rear sub-frame rails.

G. The fuel cell recessed well support frame must be constructed using three (3) tubes of one (1) inch square magnetic steel tubing with a minimum wall thickness of 0.065 inch, meeting the ASTM A-513 specification, equally spaced and must be 9-1/2 inches center to center across the recessed well. These tubes must be completely welded to the fuel cell front and rear crossmembers. The bottom of the fuel cell recessed well must be stitch welded, using one (1) inch of weld every three (3) inches, to both sides of each one (1) inch by one (1) inch vertical and horizontal support frame tube. The support tubes must extend down the front and rear, and under the fuel cell container recessed well and must be located according to the Construction Guidelines at the rear of the Rule Book.

20C - 16.4 Fuel Filler / Vent

20C - 16.4.1 Fuel Filler

At Events where refueling is required during the Event, the fuel filler must be acceptable to ARCA Officials and meet the following minimum requirements:

A. Dry coupling systems using a probe on the fuel filler cans and a receptacle on the vehicle, must be used. Dry coupling receptacles must be bolted from the inside of the quarter panel and at an angle on the left rear quarter panel. The mounting must be as near to the top of the panel and as far back as possible.

B. An ARCA-approved closed loop vehicle refueling system, consisting of a fuel filler vehicle adapter, a fuel filler can coupler and a fuel filler can vent valve will be permitted.

C. A ground cable must be installed from the metal mounting flange of the dry coupling receptacle to the fuel cell filler plate.

D. The check valve filler neck inside diameter must not exceed 2-1/8 inches. The outside diameter must not be less than 2-1/4 inches and not more than 2-1/2 inches.

E. The maximum filler spout size is 4-1/4 inches outside diameter by eight (8) inches long, then tapering over the next 8-1/2 inches to 2-1/2 inches outside diameter extending to an overall length of 18 inches.

F. A minimum of six (6) inches of 2-1/2 inches maximum inside diameter flex hose must be used between the end of the filler spout and fuel cell neck.

G. For road course Events, ARCA Officials may require the fuel filler to be installed on the right side.

20C - 16.4.2 Fuel Cell Vent

The fuel cell must be vented as follows:

A. A single, one (1) inch minimum up to a 1-1/4 inch maximum inside diameter vent to the outside of the body must be installed at and sealed to the left rear corner in the taillight area only, except when a ARCA-approved closed loop vehicle refueling system is used. The vent must have a self-closing flap type valve that can only be opened by inserting a wire or flat metal strip to allow refueling. The vent tube must not extend more than two (2) inches outside the vehicle's bodywork. The vent tube must remain perpendicular to the taillight.

B. The fuel cell check valve vent hose neck must not exceed 1-1/4 inches inside diameter and three (3) inches length. The fuel cell check valve vent hose neck must have a bead around its outside circumference for hose retention. The fuel cell vent flexible hose must have a maximum inside diameter of 1-1/2 inches and a maximum length of 40 inches when measured from the outside end of the fuel cell check valve vent pipe to the top of the fuel cell fill plate. The fuel cell vent hose must be transparent, neoprene or convoluted Teflon® and must be acceptable to ARCA Officials. The hose must be secured with two (2) hose clamps at the fuel cell fill plate.

C. When fuel is added during a pit stop, a crew member must catch any overflowing fuel into a container acceptable to ARCA Officials except when an ARCA-approved closed loop vehicle refueling system is used. The overflow container must be metal and coated red.

D. For road course Events, ARCA Officials may require the vent to be installed on the right side.

20C - 16.5 Fuel Lines and Fuel Pump

Engine compartment mounted fuel pressure regulators must be mounted in an area on or forward of the front firewall above the engine block and between the cylinder heads. Fuel pressure may only be measured from a fuel line or engine mounted regulator at the intake manifold. Fuel lines from the carburetor will not be permitted on the cockpit side of the front firewall. Fuel pressure gauge isolators or sensors for electronic fuel pressure gauges must remain on the engine side of the front firewall.

20C - 16.5.1 Fuel Lines

The fuel lines and fuel line connections must be acceptable to ARCA Officials and meet the following minimum requirements:

A. An approved dual, right or left side fuel pickup(s) may be used. An ARCA-approved Holley hydramat fuel blanket will be permitted. The size, material and location of the fuel cell pickup must be acceptable to ARCA Officials.

B. For carbureted engines, only one (1), maximum 5/8 inch inside diameter fuel line with a maximum AN-10 fitting, will be permitted from the fuel cell to the carburetor. The length of the fuel line inside the trunk area from the fuel cell to the rear firewall must not exceed 55 inches including the fittings and fuel filter (if used).

For EFI engines, only one (1), maximum 5/8 inch inside diameter fuel line with a maximum AN-10 fitting, will be permitted from the fuel cell to the EFI. The length of the fuel line inside the trunk area from the fuel cell to the rear firewall must not exceed 90 inches. The total length will include the fuel line fittings, dual fuel pump and fuel filter(s). A maximum of two (2) fuel filters will be permitted.

C. All fuel lines must be stainless steel, full coverage, outer braid protected synthetic rubber hose attached with threaded, nipple design hose end fittings and should be covered with flame resistant covering acceptable to ARCA Officials. This includes the fuel line to the fuel pressure gauge and/or sending unit.

D. The fuel line from the fuel cell to the fuel pump may be relocated to prevent vapor lock. The fuel line running through the driver's compartment, must be enclosed in a straight or parallel to the drive shaft and transmission tunnel (as viewed from above) maximum 1-1/4 inch outside diameter metal tube, painted red and labeled "FUEL LINE", mounted near the floor pan between the transmission tunnel and the inside of the right side frame rail. The fuel line must not be mounted more than six (6) inches above the floor pan then rising toward the firewalls forward of the dash panel bar (#8) and rearward of the horizontal tunnel bar (#6). The fuel line must not be mounted to any roll bars inside the driver's compartment. The fuel lines and location must be acceptable to ARCA Officials.

E. An ARCA-approved check valve mounted at the fuel line outlet on the fuel cell may be used.

F. Additional lines or extra length must not be used on the fuel system. Extra fuel lines or fuel cells, concealed or otherwise, will not be permitted.

G. Quick disconnect fittings will not be permitted.

H. Only one (1) fuel filter may be used between the fuel cell and the fuel pump for carbureted engines. The fuel filter must be mounted on the rear firewall forward of the fuel cell container. The fuel filter must be located on or near the center of the firewall and the fuel line must pass through the right half of the firewall. The size of the fuel filter, without fittings and end caps, must not exceed 8-1/2 inches in length and 2-1/2 inches outside diameter and must have a minimum wall thickness of 0.100 inch. The fuel filter assembly must meet or exceed a minimum pressure rating of 150 psi and must be acceptable to ARCA Officials. Fuel filter(s) on the pressure side of the fuel pump must only be used at the carburetor fuel bowl inlets. When the ARCA Ilmor engine is used a maximum of two fuel filters will be permitted. The fuel filter(s) must be mounted to the fuel cell top rack or rear firewall.

20C - 16.5.2 Fuel Pumps

Fuel pumps must be acceptable to ARCA Officials meeting the following requirements:

A. For carbureted engines, a mechanical, lever-action, camshaft actuated fuel pump in the approved location will be permitted.

B. An ARCA-approved, remote cable driven mechanical fuel pump will be permitted for carbureted engines, except the approved "Spec Engine". The pump must be driven off of the rear of the engine oil pump. The cable driven fuel pump must be mounted in the trunk area on the rear firewall, forward of the fuel cell container near the center of the chassis. If a remote fuel pump is used, the fuel line fitting on the inlet side of the remote fuel pump may be a manufacturer certified, crash-worthy, break-away, self sealing type. It is recommended that the remote cable assembly meet the SFI 8.1 specification.

C. Electric fuel pumps will not be permitted, except when the ARCA Ilmor engines are used.

D. The ARCA Ilmor engines must use the Holley dual fuel pump Part #12-873 or Part #12-868 and Holley fuel pressure regulator Part #12-872. The fuel pumps and pressure regulator must be mounted to the fuel cell top rack on the left side.

E. Liquid cooling of the fuel pump will not be permitted.

20C - 16.6 Fuel Filler Cans

A. Unless authorized by ARCA, a maximum of three (3) approved maximum 12 gallon metal fuel filler cans will be permitted in the pits at all tracks.

B. The metal fuel filler cans must be coated red and be acceptable to ARCA Officials. (See Diagram in the rear pages of the Rule Book for an ARCA-approved fuel filler can.) The only decals used beyond those of ARCA Officials that will be permitted on any fuel filler can will be those of a participating fuel supplier that is approved by ARCA. The fuel filler can must be metal, ventilated and equipped with a flexible filler nozzle.

C. When an ARCA-approved closed loop vehicle refueling system is used, the metal fuel filler cans must be equipped with a vent valve and vent tube.

D. The use of two (2) fuel filler cans at the same time to refuel the vehicle will not be permitted.

E. Elevated fuel drums or refueling towers will not be permitted.

F. Only metal fuel filler cans without dry coupling system fuel probes, coated red, acceptable to ARCA Officials, will be permitted to be used to refuel the vehicle in the garage area or pit area. When adding or removing fuel to/from the vehicle in the garage area, the vehicle must be outside of the garage structure. When teams are parked behind the team's transporters in the garage area, the vehicle must be moved away from the transporters before adding or removing fuel to/from the vehicle. ARCA Officials may require that fuel be added or removed to/from the vehicle in a designated area of the garage.

G. Fuel filler cans must not be stored in the garage structure.

H. The fuel filler cans must only be transported from the fuel station to the pit area in a cart acceptable to ARCA Officials.

I. When installing or removing fuel can couplers, power tools **MUST NOT** be used. It is recommended that a non-conductive nut driver be used.

20C - 17 PERSONAL SAFETY EQUIPMENT

A. General

1. Each Competitor is solely responsible for the effectiveness of personal safety equipment used during an Event. ARCA IS NOT RESPONSIBLE FOR THE EFFECTIVENESS OF ANY PERSONAL SAFETY EQUIPMENT.

2. Each Competitor is expected to investigate and educate himself/herself fully with respect to the availability and effectiveness of personal safety equipment. ARCA may, from time to time, schedule information sessions with Competitors and safety experts. Each Competitor is expected to attend and participate in such sessions.

B. Protective Clothing

IT IS THE RESPONSIBILITY OF THE DRIVER AND CREW MEMBER, NOT ARCA, TO ENSURE THAT HE/SHE MAINTAINS, WEARS AND PROPERLY USES PROTECTIVE CLOTHING.

DRIVERS – Unless otherwise authorized, while on the track during the Event, Drivers must comply with the following:

	Use Required	Use Recommended	SFI / FIA Specification (minimum)	SFI Specification (recommended)	SFI Label Visibly Displayed
Uniform	X One-piece Uniform		3.2A/5	3.4	Outside Surface of Left Sleeve
Shoes	X		3.3		X
Gloves	X		3.3		X
Head Sock and/or Helmet Skirt	X		3.3 FIA 8856-2000 FIA 8856-2018		X
Underwear/ Socks	X		3.3 FIA 8856-2000 FIA 8856-2018		X
Helmet	X Refer to Section 20C17.1A Helmets				Helmet Certification Label Affixed To Helmet At All Times

CREW MEMBERS – During race conditions, any crew member who steps into the vehicle servicing area must comply with the following:

	Use Required	Use Recommended	SFI / FIA Specification (minimum)	SFI Specification (recommended)	SFI Label Visibly Displayed
Uniform	X		3.2A/1	3.2A/5 or 3.4	Outside Surface of Left Sleeve
Shoes	X		3.3		X
Gloves	X		3.3		X
Head Socks (Must Cover Nose & Mouth)	X		3.3 FIA 8856-2000 FIA 8856-2018		X
Helmet Skirts		X			X
Underwear		X		3.3	
Socks		X		3.3	
Helmet	X Refer to Section 20C17.1A3 Helmets				

FUEL HANDLER/FUELER (CREW MEMBER) – During race conditions, any crew member involved in fueling the vehicle or handling or transporting fuel in the garage or pit area must comply with the following:

	Use Required	Use Recommended	SFI / FIA Specification (minimum)	SFI Specification (recommended)	SFI Label Visibly Displayed
Uniform	X		3.2A/5	3.4	Outside Surface of Left Sleeve
One-Piece Uniform		X		3.2A/5 or 3.4	Outside Surface of Left Sleeve
Shoes	X		3.3		X
Gloves	X		3.3		X
Apron	X		52.1		X
Underwear		X		3.3	X
Socks		X		3.3	X
Head Socks* and/or Helmet Skirt Must Cover Nose & Mouth	X		3.3 FIA 8856-2000 FIA 8856-2018		X
Full-face Helmet with Covering Face Shield	X Refer to Section 20C17.1A Helmets				Helmet Certification Label Affixed To Helmet At All Times

C. Onboard Fire Suppression

1. It is required that each vehicle have two (2) distinct, fully charged onboard fire suppression systems (OBFSS), one servicing the driver's compartment (cockpit) and the second servicing the fuel cell area (trunk) and engine compartment. OBFSS must be installed, maintained and used in accordance with the manufacturer's/suppliers directions. The OBFSS systems must meet the SFI 17.1 specification and display a valid and visible SFI 17.1 label. The OBFSS cylinders must be certified by the manufacturer every two (2) years. An additional manufacturer's label with a visible date code must be located directly below the pressure gauge on the surface of each OBFSS cylinder.
2. Both OBFSS cylinders must have a visible operating pressure gauge, compatible with the agent and be charged with DuPont FE-36, 3M NOVEC 1230 or equivalent agent. Equivalent agents are determined by ARCA. Shut off valves are not permitted within the onboard fire suppression systems.
3. Both OBFSS cylinders must be DOT-approved and constructed of steel or aluminum.
4. The driver (cockpit) area OBFSS cylinder must contain a minimum of five (5) pounds of agent. All discharge lines and fittings must be steel or steel reinforced hose. The OBFSS nozzles may be aluminum and must be appropriate for the agent and must be installed per the manufacturer's

instructions.

5. The fuel cell area (trunk) and engine compartment OBFSS cylinder must contain a minimum of ten (10) pounds of agent. This cylinder must be thermally activated (may have manual and/or pneumatic override) discharge nozzle(s) appropriate for the agent and installed per the manufacturer's instructions. The nozzle(s) may be aluminum.
6. All discharge lines and fittings must be steel or steel reinforced hose.
7. The fuel cell area (trunk) line must remain in the passenger compartment and only breach the firewall to enter directly into the fuel cell (trunk) area near the longitudinal centerline of the vehicle. The discharge nozzles must be secured with clamps constructed of metal. Placement and orientation of the discharge nozzle are the responsibility of the team according to their installations and OBFSS manufacturer instructions.
8. The engine compartment line must remain in the passenger compartment and only breach the front firewall once. The thermal discharge nozzle must be secured with metallic hardware. Placement and orientation of the discharge nozzle are the responsibility of the team according to their installations and OBFSS manufacturer instructions. The engine compartment discharge nozzle may only pass through the front firewall within an area between thirteen inches outward from the right side of the front windshield bar (#4) and a maximum of four (4) inches downward from the top of the front firewall.
9. Both OBFSS cylinders must be securely mounted in one or both of the following locations.
 - a. To the right of the driver's seat. The cylinder(s) and its mount(s) must not be beyond the inside edge of the right side main frame rail.
 - b. Behind the driver's seat. The cylinder(s) must be mounted to and parallel to the horizontal tunnel bar (#6).
 - c. The cylinders must be mounted with the operating pressure gauge visible and facing the center of the vehicle.

The mounting system must secure both ends of the cylinders for their full circumference to the structure of the vehicle. Hose clamps, worm drive clamps or cable ties will not be permitted. A device(s) must be installed to keep the cylinders from sliding out of the mounting system. Clamp style or "figure eight" mounts must completely encircle the circumference of the 1-3/4 inch outside diameter of the roll bar. The mounting system and location must be acceptable to ARCA Officials.
10. A manually controlled push/pull nozzle activation knob which activates the driver (cockpit) area OBFSS system must be used (thermally activated discharge nozzle is recommended). The manually controlled activation system must only use the OBFSS manufacturer's supplied push/pull cable, push knob or other manual activation device. The activation device must be mounted within the drivers reach to either the left or right-side leg extension or the left side dash panel. While on track, the lock pin must be removed from the manually controlled push/pull activation device. A red tag with white lettering stating, "REMOVE BEFORE ON TRACK" must be attached to the lock pin.

D. All competitors must have in their garage or pit area as part of their equipment, at all times, a fully charged minimum 10 pound, Class B fire extinguisher with a visible, operating pressure gauge.

E. Passengers will not be permitted in or on a race vehicle at any time.

20C - 17.1 Helmets / Head and Neck Restraint Devices / Systems

A. Helmets

1. Drivers must wear a full-face helmet carrying at least one (1) of the following certifications:
 - FIA 8860-2010 (with a date of manufacture after January 1, 2016)
 - FIA 8859-2015 (with a date of manufacture after January 1, 2020)
 - FIA 8860-2018
 - Snell SA 2015
 - Snell SA 2020

Helmet certification (label) must be affixed to the helmet at all times.

Helmets should be fitted with an ARCA-approved helmet removal system. The following systems are currently approved:

Eject™ Helmet Removal System

2. The driver must wear the helmet in accordance with the directions provided by the helmet supplier and/or manufacturer. Any modification to the helmet for any purpose should not detract from its effectiveness. Helmet surface protrusions such as visor tear-off posts should be removed.
3. During Race conditions, any crew member who steps into the vehicle servicing area must wear a helmet and a fire resistant head sock. The head sock must meet the SFI 3.3 specification and must visibly display a valid

SFI 3.3 label.

4. During Race conditions, any crew member involved in fueling the vehicle must wear a full-face helmet with a covering face shield and a fire resistant head sock and/or helmet skirt. The head socks and/or helmet skirts must meet the SFI 3.3 specification and must visibly display a valid SFI 3.3 label. Helmets should be fitted with an ARCA-approved helmet removal system.

The following systems are currently approved:

Eject™ Helmet Removal System

5. IT IS THE RESPONSIBILITY OF THE DRIVER/CREW MEMBER, NOT ARCA TO ENSURE THAT HIS/HER HELMET IS APPROVED, CORRECTLY WORN, MAINTAINED AND PROPERLY USED.

B. Head and Neck Restraint Devices / Systems

1. At all times during an Event (practice, qualifying and competition), drivers must connect their helmet to an approved head and neck restraint device/system which is SFI-approved and acceptable to ARCA. The device/system must meet the SFI 38.1 specification and must display a valid SFI 38.1 label. The head and neck restraint device/system, when connected, must conform to the manufacturer’s mounting instructions, and it must be configured, maintained and used in accordance with the manufacturer’s instructions.
2. IT IS THE RESPONSIBILITY OF THE DRIVER, NOT ARCA, TO ENSURE THAT HIS/HER DEVICE/SYSTEM IS SFI-APPROVED, CORRECTLY INSTALLED, MAINTAINED AND PROPERLY USED.
3. The following are the SFI-approved Head and Neck Restraint Devices/ Systems that are currently acceptable to ARCA:

MANUFACTURER	MODEL	OPTIONS
HANS	Professional Series	Fixed or Sliding Tethers
HANS	Extra/Economy Series	Fixed or Sliding Tethers
HANS	Pro Ultra	Sliding Tethers
HANS	Sport Series	Fixed or Sliding Tethers
HANS	Sport II Series	Sliding Tethers
HANS	Stilo HANS Zero	Sliding Tethers
Safety Solutions	Hybrid	Fixed Tethers
Safety Solutions	Hybrid Pro	Fixed Tethers
Simpson <i>(formerly Hutchens)</i>	Hybrid	Fixed Tethers
Simpson	Hybrid Pro	Sliding Tethers
Simpson	Hybrid Pro, carbon	Fixed Tethers
Stand21	Featherlite	Sliding Tethers

C. SFI 38.1-approved head and neck restraint devices/systems will remain approved for use in competition until their expiration date which is five (5) years after the date of manufacture. At this time, the head and neck restraint device/system must be returned to the manufacturer for inspection and re-certification.

20C - 17.2 Seat Belts

A. IT IS THE RESPONSIBILITY OF THE DRIVER, NOT ARCA, TO ENSURE THAT HIS/HER SEAT BELT RESTRAINT SYSTEM AND ALL COMPONENTS ARE SFI 16.5-APPROVED OR 16.6-APPROVED AND LABELED, CORRECTLY INSTALLED, MAINTAINED AND PROPERLY USED.

B. Each vehicle must be equipped with an SFI 16.5-approved, minimum 6-point seat belt restraint system that displays a valid SFI 16.5 label. It is recommended that an SFI 16.6-approved seat belt restraint system that displays a valid SFI 16.6 label be used. When the 16.6-approved seat belt system is used it must be either a 7 point or 9 point system only. When an ABTS (All Belts To Seat) seat is used the 16.6-approved seat belt system must be used. The shoulder harness and lap belt assembly must not be more than three (3) inches (nominal) in width. The shoulder harness must not be less than two (2) inches wide (nominal) as it passes over the approved head and neck restraint system. Approved seat belt restraint systems must have a latching mechanism attached to the lap belt or, if a cam lock latching mechanism is used, it must be attached to the lap belt, the shoulder harness or the anti-submarine belts. This latching mechanism must provide a common connection and release for the lap belt, shoulder harnesses and the anti-submarine belts, and must be designed with a quick and easy one-handed, gloved release of all belts in all conditions. It must have one (1) of two (2) approved release designs:

1. **Latch/Lever:** Utilizes a lever opening away from the body in a right to left hand movement, parallel to the lap belt with complete release of all belts. The lever must have a provision to prevent an unintentional release.
2. **Cam Lock:** A circular handle or raised surface that turns in both directions for a motion of not less than 30 degrees before completely releasing all

belts. A downward facing tab or toggle may be used, provided that its length does not extend more than 1/2 inch beyond the outer diameter of the release mechanism unless a provision to prevent unintentional rotation or release is provided.

C. The seat belt restraint system must be installed in accordance with the directions provided by the system supplier and/or manufacturer. In addition, please note the following guidelines:

1. Lap belts must be installed and used in such a manner that, when secured to the latching mechanism, the seat belt webbing travels in a straight, clear and free path from the belt mount through the seat opening to the latching mechanism. Lap belt mounts must be able to swivel without binding or interference. When the driver is buckled in the seat, the free end of the seat belt webbing must rest in a position clearly aligned over the seat belt webbing entering any adjustment or latch release hardware.
2. On the left lap belt, if a roller adjuster is used, it must have tension springs installed and it must be attached to and be a part of the latch release mechanism directly without any webbing loop. The roller adjuster must not be attached to the lap belt mounting tab at the frame. A 3-bar slider, threaded to the manufacturer's instructions, may be used for the left lap belt length adjustment, in the absence of the roller adjuster. The 3-bar slider must be positioned outside the seat opening and as close to the mounting tab as possible. On the right lap belt, if a roller adjuster is used, it must have tension springs installed and the adjuster may be located anywhere on the belt except at the frame mounting tab. A webbing link may be used to connect the roller adjuster to the latching mechanism or a 3-bar slider, threaded to the manufacturer's instructions, may be used for the right lap belt length adjustment, in the absence of the roller adjuster. The 3-bar slider must be positioned outside the seat opening and as close to the mounting tab as possible. Wrap-around style lap belt mounts and clip-on/hook/eyebolt style mounts will not be permitted, only tab style lap belt mounts secured with a nut and bolt will be permitted for aluminum seats. ARCA-approved composite material seats must use the lap belt mounts which are integral with the seat and must be of the same mount style as approved with the seat.
3. Shoulder belts must mount to horizontal shoulder bar (#7) or shoulder belt bar (#7B) only (as shown in the Diagram in the rear pages of the Rule Book). If shoulder belt mounting brackets are used, the shoulder belt mounting brackets must not exceed three (3) inches in length and be a minimum 1-3/4 inches in width. The shoulder belt mounting brackets must be made of solid magnetic steel with a minimum thickness of 3/16 inch welded to the horizontal shoulder bar (#7) or shoulder belt bar (#7B). The shoulder belt mounting holes must have a minimum edge-to-hole distance of 1/4 inch. If the shoulder belt bar (#7B) is used, and the center-to-center distance from the horizontal shoulder bar (#7) is more than four (4) inches, then the shoulder belts must mount directly to the shoulder belt bar (#7B) or to tabs welded directly to the shoulder belt bar (#7B). The opening in the seat for this type of belt must be either a single or double open slot with a finished inside edge or a grommet installed. Only individual shoulder harness belts will be permitted. Y-type shoulder harnesses will not be permitted. Wrap-around shoulder harness mounts will be permitted provided the belts do not cross behind the driver and all wrap-around mount style shoulder belts must be retained by a guide on horizontal shoulder bar (#7) or shoulder belt bar (#7B) to prevent lateral movement of the belt on the roll bar. Shoulder belts may cross behind the driver provided they use a tab-style mount and not a wrap-around mount. The seat opening for these crossed shoulder belts must be a single, open slot with a finished inside edge or grommet where the shoulder belts cross behind the driver. Each shoulder belt using a tab mount must use an individual mounting tab or a steel sleeve welded through horizontal bar (#7) or shoulder belt bar (#7B) and be secured with a nut and bolt. Roller adjusters on the shoulder harnesses must have tension springs installed. Sternum or cross belts using metal or hard surface hardware will not be permitted.
4. Approved anti-submarine belts must be mounted to the seat frame or a steel reinforced seat bottom mount. Either wrap-around or tab-style anti-submarine belt mounts will be permitted and must be installed in accordance with the directions provided by the system supplier and/or manufacturer.

D. The manufacturer's label must not be located under the adjusting mechanism when the driver is buckled in the seat and has tightened the seat belts and shoulder harness. If the label is under the adjusting mechanism, the label may be removed and relocated in a manner that does not affect the integrity of the belt material. The date of manufacture must remain visible on the belt at all times. Seat belt restraint systems must not be used beyond two (2) years after their date of manufacture.

E. The driver must use the seat belt restraint system at all times on the race track

in accordance with the instructions and/or recommendations of the system supplier and/or manufacturer, as set forth above.

F. The SFI 16.5 and 16.6-approved seat belt restraint systems will remain approved for use in competition until their expiration date which is two (2) years after the date of manufacture. The seat belt restraint systems must be used as a complete restraint system. Brands may not be mixed.

20C - 17.3 Seats

A. IT IS THE RESPONSIBILITY OF THE DRIVER, NOT ARCA, TO ENSURE THAT HIS/HER SEAT, HEADREST/HEAD SURROUND ASSEMBLY AND ALL SEAT COMPONENTS ARE CORRECTLY INSTALLED, MAINTAINED AND PROPERLY USED.

B. Each vehicle must be equipped with an SFI 39.1 approved seat and headrest/head surround assembly displaying valid SFI 39.1 labels and be acceptable to ARCA. Custom-manufactured aluminum seats constructed from solid aluminum sheet material from the seat bottom to above the driver's shoulders, acceptable to ARCA, will be permitted. ARCA-approved composite material seats will be permitted. Composite material seats and/or seats which incorporate lap and/or shoulder belt anchorages are subject to additional testing with documentation supplied to ARCA. Each composite seat must have a unique, identifier that matches records on file with ARCA. Seats constructed of multiple materials, including composite materials, must be SFI 39.1-approved and must be acceptable to ARCA. The SFI 39.1-approved seat and headrest/head surround assembly will remain approved for use in competition until their expiration date which is two (2) years after the date of manufacture. Once a seat and headrest/head surround assembly has reached the expiration date, the seat and headrest/head surround assembly must be inspected and recertified by the seat manufacturer.

Effective January 1, 2025, Only SFI 39.1 approved ABTS (All Belts To Seats) will be permitted.

C. All seat interiors must be lined with inserts and/or padding meeting the SFI 45.2 specification and display a valid SFI 45.2 label. Any additional non-SFI 45.2 insert/padding materials used must not exceed a maximum thickness of 1/2 inch. No gaps or non-SFI 45.2 specification material(s) may be present between the seat structure and driver's uniform in the area directly under the driver with the exception of standard seat cover upholstery, with a maximum thickness of 1/4 inch or flame retardant knit materials. A minimum thickness of 3/4 inches of insert/padding meeting the SFI 45.2 specification must be used in this area directly under the driver. The area directly under the driver extends from the driver's waist (belt line) forward to the front edge of the sub-strap pass through holes or four (4) inches forward of the lap belt mount, whichever is greater, as well as extends five (5) inches to both the left and right of the driver's centerline. The area directly under the driver is shown in Diagram #9, in the rear pages of the Rule Book. A 3/8 inch diameter inspection through-hole must be located on the driver's centerline between the leading edge of the lap belt pass through holes as shown in Diagram #19, in the rear pages of the Rule Book. All seat coverings and/or upholstery should be flame retardant.

D. The seat and headrest/head surround assembly must be installed in accordance with the directions provided by the system supplier and/or manufacturer. SFI 39.1 seats and headrest/head surround assemblies must not be modified or altered. The back of the seat, at shoulder level, must be positioned as close to the horizontal shoulder bar (#7) as possible.

E. All seats must have padded seat leg extensions on the left side and the right side. Leg extensions must be securely mounted to the seat and vehicle structure. Leg extensions must be padded. It is recommended that the padding meet the SFI 45.2 specification and display a valid SFI 45.2 label. Composite material seat leg extensions should meet the SFI 56.1 specification for flammability. All leg extension coverings and/or upholstery should be flame retardant.

F. Headrests/head surround assemblies must be designed to provide rigid support around both sides of the helmet, across the back of the helmet and to the forward most point of the helmet chin bar. Extra length on the head surround must also account for forward head motion during impact. The left side of the headrest/head surround assembly may be shortened to permit egress of the driver but must not be shortened to a location rearward of the helmet chin bar. Foam, tape or other non-original coverings may not be added to the headrest without the approval of the seat manufacturer and must be acceptable to ARCA Officials. The headrest/head surround assembly must be rigidly bolted to the top of the seat using a minimum of 5/16 inch diameter bolts, except for the ARCA-accepted composite seats. Steel brackets welded to the roll cage must be a minimum 1/8 inch thick and aluminum brackets welded to the headrest/head surround assembly should be a minimum 3/16 inch thick. All bolts must have a minimum of 3/4 inch of metal from the center of the mounting bolt to the edge of the bracket. In addition, it is recommended that the headrest/head surround assembly be bolted to the shoulder supports with a minimum 3/16 inch thick brackets and a minimum 5/16 inch diameter bolts. The headrest/head surround assembly must not extend into the window opening

beyond the area defined by the upper roll cage. All headrests must be fabricated in a rigid construction and of materials which provide adequate support in an impact.

G. All headrest/head surround assemblies must be lined with inserts and/or padding meeting the SFI 45.2 specification and display a valid SFI 45.2 label. Except for Road Course Events, the headrest/head surround assembly must be padded with flat impact absorbent material, a minimum of four (4) inches thick on the right side and a minimum of 2-1/2 inches thick on the left side, meeting the SFI 45.2 specification. For Road Course Events, the insert and/or padding in the headrest/head surround assembly may be a minimum of three (3) inches thick on both the right side and left side.

H. Optional strap-type headrest supports or nets must be equipped with a quick release fastener accessible by the driver.

I. The upper seat back must be secured to horizontal shoulder bar (#7) or to a bracket that is secured to horizontal shoulder bar (#7) with a minimum of three (3) high quality 5/16 inch minimum diameter bolts through the horizontal shoulder bar (#7). For aluminum seats, if a seat bracket is used to attach the seat to the horizontal shoulder bar (#7), the bracket must be constructed using a minimum of 3/16 inch thick metal plate, and it must have a minimum of 3/4 inch of metal from the center of the mounting bolt to the edge of the bracket or the bracket may utilize the composite seat bracket design. For composite seats, the seat bracket must attach the seat to the horizontal shoulder bar (#7) and must be constructed from magnetic steel.

Minimum upper seat bracket thicknesses:

Hendrick; 0.090 inch

Sabelt; 3/16 inch

Sparco; 3/16 inch

The magnetic steel seat bracket to be used with a composite seat must be constructed according to the manufacturer's instructions, including all required gussets and reinforcements (see Diagrams # 8A & B, in the rear pages of the Rule Book). All gussets must be solid and must run from the centerline of the seat mounting hole to the centerline of the roll cage mounting hole. The outer diagonal gusset edge must be straight unless the gusset is relieved to make room for the horizontal shoulder bar (#7). Holes and or other modifications that, in the judgment of ARCA Officials were made with the intent of weight reduction will not be permitted.

The seat bracket must be fastened to the seat with a minimum of four (4) high quality 5/16 inch minimum diameter bolts for aluminum seats manufactured with four (4) mounting holes. Aluminum seats manufactured with three (3) mounting holes for the seat bracket must be fastened to the seat bracket with a minimum of three (3), high quality 5/16 inch minimum diameter bolts. Composite seats must be fastened to the seat bracket with a minimum of three (3), high quality 5/16 inch minimum diameter bolts.

J. The seat bottom must be secured to the vehicle's frame/roll cage assembly with a tubular seat frame in a symmetrical fashion with a minimum of two (2) high quality 5/16 inch minimum diameter bolts per side. Seat mount brackets and/or mounting systems must be a minimum of 1/4 inch thick. All mounting brackets must have a minimum of 1/2 inch of metal from the center of the mounting bolt to the edge of the bracket. All seat mounting brackets, welded to the frame rail, frame crossmembers, floors, roll bars, or removable seat mounting frame assemblies, must be made of a minimum of 1/4 inch magnetic steel if single shear or a minimum of 3/16 inch if the double shear configuration is used. If a slotted mount is used to mount the seat to the seat frame, the seat must be bolted to the seat frame bracket using an additional bolt to prevent sliding. When mounting through aluminum seats or brackets, large diameter washers must be used.

When an ABTS (All Belts To Seat) seat is used the seat must be secured to the vehicle's frame/roll cage assembly with a tubular seat frame which includes the seat mounting brackets. The tubular seat frame must be constructed from ASTM A513 type 5 round magnetic steel tubing with a 1-1/4 inch outside diameter and a 0.115 inch minimum wall thickness. The tubular seat frame must be secured at each end in a double shear configuration or must be welded at each end. If welded, a gusset must be used at each end. If using tubular seat frame mounting brackets, the tubular seat frame must have welded bungs with a 3/8 inch inside diameter installed. The welded bung must use a 3/8 inch magnetic steel hex head bolt or the welded bung may be threaded the entire length and welded around the entire circumference. A 5/8 inch maximum diameter through hole may be used on main frame assembly to locate weld bung. If tubular seat frame mounting brackets are used the mounting brackets must solid magnetic steel with a minimum thickness of 3/16 inch and a minimum bottom width of 1-1/4 inch. The seat frame mounting brackets must be completely welded to the main frame assembly and/or the horizontal tunnel bar (#6). Each mounting bracket must have a 3/8 inch seat frame mounting hole to attach the seat frame to the bracket. Slots will not be permitted in the seat frame mounting hole. The mounting hole must not be higher than 2-1/2 inches from the lower edge of the mounting bracket. The mounting bracket must have a minimum of 5/16 inch of metal from the edge of the mounting bolt to the outer edge of the bracket. All seat mounting frame configurations and specifications are shown in diagrams #8C and 8D in the rear pages of the Rule Book.

When an ABTS (All Belts To Seat) seat is used the seat must be secured to the

vehicle's tubular seat frame assembly and horizontal shoulder bar (#7). An approved upper seat mounting bracket shown in diagram 8A in the rear pages of the Rule Book must be used. All upper seat brackets must be a minimum thickness of 0.090 inch. The upper seat bracket must be secured to the seat with a minimum of three (3) high quality 5/16 inch minimum magnetic steel bolts. The upper seat bracket must be secured to the horizontal shoulder bar (#7) with a minimum of three (3) high quality 5/16 inch minimum magnetic steel hex head bolts through the horizontal shoulder bar (#7). The seat bottom must be secured to the seat mounting brackets with a high quality 5/16 inch minimum magnetic steel hex head bolt two (2) per side using the seat manufacturer's designated mounting locations. The seat mounting brackets must be completely welded to the tubular seat frame. The seat bottom mounting brackets must be solid magnetic steel with a minimum thickness of 1/4 inch. The seat mounting bracket must have a minimum width of 1-1/2 inch or a maximum width of 2-1/2 inches at the bottom. The seat mounting bracket must have a 5/16 inch minimum mounting hole to attach the seat to the bracket. Slots will not be permitted in the seat mounting hole. The mounting hole must not be higher than four (4) inches from the lower edge of the mounting bracket. The mounting bracket must have a minimum of 5/16 inch of metal from the edge of the mounting bolt to the outer edge of the bracket. Seat mounting bracket configurations and specifications are shown in diagram 8D in the rear pages of the Rule Book.

K. The seat shoulder support angle should not exceed 25 degrees from vertical when measured where the driver's shoulder contacts the seat with the seat installed in the vehicle. Additional angle may be added to the bottom of the shoulder support for driver arm clearance, if necessary. The interior shoulder support surface should be positioned perpendicular to the seat back in a plan view.

L. Rib/chest support structures, if used, should not interfere with the natural ingress and egress of the driver from the seat. Rib/chest support structures, if used, should provide full coverage from the seat back to the front of the driver's chest. Partial rib/chest supports constructed of foam, meeting the SFI 45.2 specification, will be permitted. Rib/chest support structures should not continue forward past the front of the driver's chest and should not curve or wrap around the front of the driver's chest. Rib/chest support foam, meeting the SFI 45.2 specification will be permitted to curve or wrap around the front of the driver's chest.

20C-17.4 Window Net

A. A window net meeting the SFI 27.1 specification and displaying a valid SFI 27.1 label must be installed in the left side door window opening. The window net must not be used beyond two (2) years from the date of manufacture.

B. The window net must be a rib-type construction made from minimum 3/4 inch, maximum one (1) inch wide material, with a minimum one (1) inch square opening between the ribs. The minimum window net size must be 20 inches wide by 14 inches high. Window net webbing must not be attached to the B-pillar. No flap(s) or additional material may be present on the driver's window net.

C. All window net mounts must be welded directly to the roll cage and must not attach to the door top or exterior body panel. All upper and lower window net mounts must be constructed using a minimum 1/2 inch diameter magnetic steel rod or a minimum one (1) inch wide by 1/8 inch thick flat magnetic steel and must be acceptable to ARCA Officials. The lower window net mounting bar must not extend above the door top.

D. The window net when in the closed position must fit tightly and be secured with a lever-type quick release latch acceptable to ARCA Officials. The lever must be secured by a detent ball in the lever and may be supplemented by a Velcro® fastener only; pins or clips will not be permitted. The latch must be mounted at the top in the front to the roof bar (#3) or at the top of the left front roll bar leg (#2A) near the roof bar (#3).

20C - 18 Roll Bars

A. As a minimum, all vehicles are required to have the basic and typical roll cage configured as shown in Diagrams #2, #3, #4, and #4A. Unless otherwise specified below, all roll bars must be made from round magnetic steel seamless tubing 1-3/4 inches by 0.090 inch thick minimum wall thickness meeting the ASTM A-519 specification. Electric resistance welded tubing, aluminum and/or other soft metals will not be permitted. Roll bar joints and intersections must be welded according to the ASTM specification for the material being welded. A maximum of one (1), maximum 1/8 inch diameter hole may be drilled at each welded roll cage joint for the purpose of purging the tubes when welding. Once constructed and installed, the roll cage must be acceptable to ARCA Officials. Holes and/or other modifications that, in the judgment of ARCA Officials, were made with the intent of weight reduction will not be permitted. Modifications or alterations which detract from or compromise the integrity or effectiveness of any roll cage component will not be permitted.

B. Basic ARCA Roll Cage Structure

1. The main roll bar (#1 in Diagram #4) must be a continuous length of tubing with one end welded perpendicular to the top of the right frame rail and one end welded perpendicular to the top of the left frame rail and with both rising vertically a minimum of 21-1/4 inches before bending inward to

maintain a minimum clearance with the “B” posts and follow along the inner surface of the roof panel with minimum clearances for both the roof panel and the hinged air deflectors. The main roll bar (#1) must also be braced with one (1) diagonal bar (#5) and two (2) horizontal bars (#6) and (#7). All bends in the main roll bar (#1) must be as symmetrical as minimum clearances permit.

2. The distance from the center of each of the front roll bar legs (#2 A & B) to the center of the main roll bar (#1) must not measure less than 42-3/4 inches. Each of the front roll bar legs (#2 A & B) must be constructed from a continuous length of tubing. One leg must be welded perpendicular to the top of the right frame rail and one leg welded perpendicular to the top of the left frame rail with both legs rising vertically a minimum of 21-1/4 inches before bending inward and rearward to maintain a minimum clearance with the “A” posts. Both legs must follow along the inner surface of each respective “A” post. The front roll bar legs (#2 A & B) must be welded to the roof bar (#3) near the upper corners of the windshield.

When the Grand National-Approved (Flange Fit) Composite Body is used the front roll bar legs (#2 A & B) may be spliced and sleeved to reach the minimum roof bar (#3) height of 48 inches as described in this sub-section (B 3). If the front roll bar legs are spliced and sleeved they must meet the following requirements:

Front roll bar legs (#2 A & B) may only be spliced and sleeved in the straight length above the top door bar (#9 A & B) and the dash panel bar (#8) respectively.

The spliced area must be cut at an angle and welded where both the upper and lower sections of tubing join.

The splice sleeve must be a minimum of six (6) inches in length and extend internal into both the upper and lower sections of the front roll bar legs (#2 A & B).

Both the upper and lower sections of tubing must be drilled with a minimum of eight (8) 5/16 inch minimum and 7/16 inch maximum holes with a rosette weld. Rosette weld must remain intact and may not be ground.

3. The roof bar (#3) must be a continuous length of tubing extending forward from the outer edges of the main roll bar (#1) with minimum clearance to the roof panel and remains parallel to the main frame rails. The roof bar must follow the contour of the windshield as it bends across the front maintaining a minimum clearance to the top of the windshield. The center to center width of the roof bar (#3) must be a minimum of 43-1/4 inches, and a minimum distance of 28-3/4 inches must be maintained from the centerline of the roof bar (#3) to the centerline of the main roll bar (#1).

When the Grand National-Approved (Flange Fit) Composite Body is used the minimum roof bar (#3) height must be 48 inches. The measurement will be from the lower edge of the roof bar (#3) and 15 inches forward of the front of the main roll bar (#1) to the ground.

4. The centerline roof bar (#4) must be a continuous length of tubing, extending from the main roll bar (#1) forward to the roof bar (#3) near the vehicle's centerline. The center windshield bar (#4A) must extend forward from the roof bar (#3) near the vehicle's centerline and bend downward following the back of the windshield with minimum clearance. The center windshield bar (#4A) must pass through the top of the dash panel and attach to a support bar under the dash panel at the firewall.
5. The main roll bar diagonal bar (#5), must form a straight line, with no bends, and must begin near the upper left bend of the main roll bar (#1) behind the driver's head and after intersecting the horizontal shoulder bar (#7), it must be welded to the lower right side of the main roll bar (#1) where the horizontal tunnel bar (#6) is welded to the main roll bar (#1).
6. Two (2) horizontal bars (#6 & #7) must each be a continuous length of tubing and must be welded, with no bends, inside the vertical legs of the main roll bar (#1) with the horizontal tunnel bar (#6) welded just above the drive shaft tunnel and the horizontal shoulder bar (#7) at a minimum height of 21-1/4 inches above the main frame rails. An additional shoulder belt bar (#7B) must be a continuous length of tubing and may be added above the horizontal shoulder bar (#7) to facilitate shoulder harness mounting height. The shoulder belt bar (#7B) must be welded to the main roll bar (#1) and the main roll bar diagonal bar (#5) or it may be a bent tube constructed of 1-3/4 inches by 0.090 inch minimum wall thickness steel, round tubing, meeting the ASTM A-519 specification, welded at each end to the

horizontal shoulder bar (#7) to form a loop above the horizontal shoulder bar (#7). The shoulder belt bar (#7B) must not be forward of the plane of main roll bar (#1).

7. The diagonal bar (#7A) must be welded near the center of the horizontal shoulder bar (#7). The diagonal bar then extends forward to a junction with the roof support bar (#12) and continues through the firewall. This diagonal bar must be welded to the right front sub-frame rearward of the spring bucket. This bar must be made from 1-3/4 inches by 0.065 inch minimum wall thickness magnetic steel seamless round tubing.
8. The dash panel bar (#8) must be a continuous length of tubing, with no bends, welded beneath the dash panel between the two (2) front roll bar legs (#2 A & B) at a minimum height of 21-1/4 inches above the main frame rail.
9. (a) The door bars (#9 A & B), on both the left and right sides, must have a minimum of four (4) bars equally spaced from top to bottom that must be welded horizontally between the vertical uprights of the main roll bar (#1) and the front roll bar legs (#2 A & B). All door bars must each be a continuous length of tubing. The top door bar on each side must maintain a minimum vertical height of 21-1/4 inches from the top of the main frame rails to its centerline and match up with the intersection of the dash panel bar (#8) at the roll bar legs (#2A & B) at the front and the intersection of the of the horizontal shoulder bar (#7) at the main roll bar (#1) at the rear. All door bars must be convex in shape. The door bars (#9 A & B) must have a minimum of six (6) vertical supports per side with two (2) equally spaced between each door bar. These supports must be made from a minimum of 1-3/4 inches by 0.090 inch wall thickness magnetic steel seamless round tubing (not numbered but shown in the left side view of Diagrams #3, #4 and #4A, in the rear pages of the Rule Book).
(b) All vehicles must have a 0.0897 inch thick magnetic steel anti-intrusion plate(s) must be securely welded to the outside of the left side door bars. The anti-intrusion plate(s) must fill the area between the horizontal centerlines of the top and bottom door bars, and the vertical centerlines of the main roll bar (#1) and the left front roll bar leg (#2A). The plate(s) must be formed to match the curvature of the door bars. Individual plates welded in the openings between each door bar will not be permitted to be inset more than 1/4 inch from the tangent or outside surface of the door bar. Plate(s) welded between the vertical upright bars should be as large as possible. All plate(s) must have the corners welded with one (1) inch of weld followed by a maximum of three (3) inches of surface not welded and followed again by a minimum one (1) inch weld.

To facilitate emergency removal of the left side door bars (#9A), the anti-intrusion plate must have six (6), 2-1/2 inch diameter holes cut in the anti-intrusion plate, with three (3) holes near each end of the plate in the following locations:

The upper two (2) holes must be centered vertically between the left side door bars (#9A-1&2), at an on-center distance of three (3) inches from the center of the left front roll bar leg (#2A) and the main roll bar (#1).

The middle two (2) holes must be centered vertically between the left side door bars (#9A-2&3), at an on-center distance of three (3) inches from the center of the left front roll bar leg (#2A) and the main roll bar (#1).

The lower two (2) holes must be centered vertically between the left side door bars (#9A-3&4), at an on-center distance of five (5) inches from the center of the front roll bar leg (#2A) and the main roll bar (#1) (Refer to (Diagram #7) at the rear of the Rule Book).

10. The vertical vent window bars (#10 A & B) must each be a continuous length of tubing, welded from the upper surface of the top door bars on the right side and left side to the front roll bar legs (#2 A & B). The vertical vent window bars (#10 A & B) must be perpendicular to the top door bars (#9 A & B).
11. The two (2) angular supports (#11 A & B) must be welded to the top of the main frame rail and to the bottom surface of the second door bar from the bottom.
12. The roof support bar (#12) must be a continuous length of tubing, with no bends that extends from the right front corner of the roof bar (#3) and down to the rear suspension crossmember. The roof support bar (#12) must be welded near the intersection with the front roll bar leg (#2 B) and the roof bar (#3).

When the Grand National-Approved (Flange Fit) Composite Body is used the roof support bar (#12) may be spliced and sleeved to reach the minimum roof bar (#3) height of 48 inches as described in this sub-section (B 3). If the roof support bar (#12) is spliced and sleeved it must meet the following requirements:

The roof support bar (#12) may only be spliced and sleeved above the diagonal bar (#7A).

The spliced area must be cut at an angle and welded where both the upper and lower sections of tubing join.

The splice sleeve must be a minimum of six (6) inches in length and extend internal into both the upper and lower sections of the roof support bar (#12).

Both the upper and lower sections of tubing must be drilled with a minimum of eight (8) 5/16 inch minimum and 7/16 inch maximum holes with a rosette weld. Rosette weld must remain intact and may not be ground.

13. The rear support bars (#13 A & B) must be continuous lengths of tubing welded to the left and the right back side of the main roll bar (#1) near the roof panel at the top. They must extend to and be welded to the top of the rear sub-frame rail within one (1) inch of the rear edge of the fuel cell.

14. The trunk reinforcement bar (#14) must be a continuous length of tubing forming a loop directly above the rear sub-frame side rails and the rear-most crossmember and be welded to the rear support bars (#13 A & B). The trunk reinforcement bar (#14) must maintain a minimum height of five (5) inches from the top of the rear crossmember to the trunk reinforcement bar (#14's) center. The trunk reinforcement bar (#14) must remain parallel to the rear sub-frame rear side rails and rear crossmember.

15. Three (3) rear vertical support bars (#15), evenly spaced, must be welded perpendicular to the top of the rear crossmember and to the bottom surface of the trunk reinforcement bar (#14). These vertical supports must be made from a minimum of 1-3/4 inches by 0.090 inch wall thickness magnetic steel seamless round tubing.

16. The two (2) front sub-frame bars (#16 A & B) must each be a continuous length of tubing a minimum 1-3/4 inch diameter by 0.090 inch wall thickness magnetic steel seamless round tubing. They must be welded to the right side and the left side of the front roll bar legs (#2 A & B) at a minimum height of 21-1/4 inches. The front sub-frame bars (#16 A & B) must extend forward through the firewall, turn down, and must be welded to the front sub-frame rails forward of the spring buckets near the radiator mount.

C. Gussets

1. Gussets must be used at the intersection where the main roll bar (#1) and the front roll bar legs (#2 A & B) meet the main frame, and the gussets must be constructed using a minimum one (1) inch wide by two (2) inches high magnetic steel box tubing.

2. Gussets must be used at the intersection where the front roll bar legs (#2 A & B) intersect the roof bar (#3), and the gussets must be constructed from a minimum 0.095 inch thick triangular-shaped magnetic steel flat plate measuring a minimum of 1-1/2 inches long on each side that is to be welded.

3. Gussets must be used at the intersection of main roll bar (#1) and the front roll bar legs (#2 A & B) with door bars (#9 A & B) and the gussets must be constructed from a minimum 0.095 inch thick triangular-shaped magnetic steel flat plate measuring a minimum of 1-1/2 inches long on each side that is to be welded.

4. Gussets must be used at the intersection of main roll bar (#1) and the rear support bars (#13 A & B), and the gussets must be constructed from a minimum 0.095 inch thick triangular-shaped magnetic steel flat plate measuring a minimum of 1-1/2 inches long on each side that is to be welded.

D. For the approved location of the various roll bars, please reference both the basic roll cage diagrams and the typical roll cage diagrams at the rear of the Rule Book.

E. Modifications to the basic and typical roll cage design described above must be submitted in blueprint and/or computer aided design (CAD) files for acceptance to the NASCAR R&D Center in Concord, North Carolina at least 60 days before the design can be entered in competition. If ARCA Officials accepts the modification as set forth in the submitted files, the Competitor must submit for inspection a completed frame and roll cage at least 30 days prior to the date of intended competition. Acceptance of the submitted blueprint and/or computer aided design (CAD) files does not guarantee acceptance of the completed frame and roll cage design, and ARCA Officials may decide not to accept such design even if it is the same as the submitted files. If ARCA Officials accepts the completed frame and roll cage, it may then be used in competition in the form accepted, unless and until the form is no longer approved by ARCA Officials.

F. All roll bars within the driver's reach must be covered with impact absorbent material manufactured to the SFI 45.1 specification and be acceptable to ARCA Officials. Impact absorbent material used on roll bars must meet the SFI 45.1 specification and be imprinted on the outside surface with the SFI logo.

G. Roll bar padding must be symmetrically positioned between the centerline of the roll bar to which it is mounted and the nearest portion of the drivers body.

H. All roll bar padding must be adhered to the roll bar with adhesive or double-sided tape.

I. All references to the roll cage, roll bars, roll cage bars or the roll cage bar design specified in other sections of the Rule Book refer to sub-section 20C-18.

J. At the discretion of ARCA Officials, additional material and/or tubing may be required to be welded to any vehicle that does not conform to the January 1, 2024 roll cage or roll bar specifications as described in sub-section 20C-18.

When the NASCAR-approved (Generation 5) frame and roll cage assembly is used it must meet the following specifications. Modifications to any of the specifications or components will not be permitted.

Roll Bars

A. All vehicles are required to have the NASCAR-approved roll cage configured as shown in Diagrams #2A, B & C, 3A & B, in the rear pages of the Rule Book. Unless otherwise specified below, all roll bars described in sub-section 20C-18 must be made from round magnetic steel seamless tubing 1-3/4 inches outside diameter by 0.090 inch minimum wall thickness meeting the ASTM A-519 specification (alloys other than mild steel will not be permitted). Electric resistance welded tubing, aluminum and/or other soft metals will not be permitted. Roll bar joints and intersections must be welded according to ASTM specifications for the material being welded. A maximum of one (1), maximum 1/8 inch diameter hole may be drilled at each welded roll cage joint for the purpose of purging the tubes when welding. Once constructed and installed, the roll cage must be acceptable to ARCA Officials. A roll cage must conform to any and all ARCA-approved comparison pieces, and/or other measuring devices as applied and measured by ARCA Officials. Holes and/or other modifications that, in the judgment of ARCA Officials, were made with the intent of weight reduction will not be permitted. Modifications or alterations which detract from or compromise the integrity or effectiveness of any roll cage component will not be permitted.

The NASCAR-approved roll cage assembly consisting of numbered bars (#1 through #19) must be ARCA-approved and meet the specifications and dimensions as described in this sub-section and shown in Diagrams #2A, B & C, #3A & B, in the rear pages of the Rule Book. The addition or removal of roll bars, from the front roll bar legs (#2A & B) to the rear sub-frame rear crossmember, will not be permitted.

B. NASCAR Roll Cage Structure

1. The main roll bar (#1) must be located and welded to the outside top surfaces of the left and right main frame rails, seven (7) inches forward of the rear ends of each frame rail when measuring to the center of main roll bar (#1). The main roll bar (#1 in Diagram #3A, in the rear pages of the Rule Book) must be a continuous length of tubing with one end welded to the top of the right frame rail and one end welded to the top of the left frame rail and with both rising perpendicular to the inspection surface (with the frame heights set at six (6) inches in the front, and eight (8) inches in the rear) 21 inches before bending inward to maintain a minimum clearance with the "B" posts and follow along the inner surface of the roof panel with minimum clearances for both the roof panel and the hinged air deflectors. The main roll bar (#1) must also be braced with one (1) diagonal bar (#5) and two (2) horizontal bars (#6) and (#7). All bends in the main roll bar (#1) must be as symmetrical as minimum clearances permit (see Diagrams #3 A & B, in the rear pages of the Rule Book).
2. The distance from the center of each of the front roll bar legs (#2 A & B) to the center of the main roll bar (#1) must measure 45-3/4 inches. Each of the front roll bar legs (#2 A & B) must be constructed from a continuous length of tubing. One leg must be welded to the outside top surface of the right frame rail and one leg welded to the outside top surface of the left frame rail with both legs rising perpendicular to the inspection surface (with the frame heights set at six (6) inches in the front and eight (8) inches in the rear) 24-1/2 inches before bending inward and rearward to maintain a minimum clearance with the "A" posts. Both legs must follow along the inner surface of each respective "A" post. The front roll bar legs (#2 A & B) must be welded to the roof bar (#3) near the upper corners of the windshield.
3. The roof bar (#3) must be a continuous length of tubing extending forward from the outer edges of the main roll bar (#1). The height of the roof bar (#3), on the left side, must be 37 inches from its bottom surface at the intersection of the main roll bar (#1) to the top of the main frame rail. The height of the roof bar (#3), on the right side, must be 36 inches from its bottom surface at the intersection of the main roll bar (#1) to the top of the main frame rail. The height of the roof bar (#3) must be 38-3/8 inches from its bottom surface at the intersection of the front roll bar legs (#2A & B) to the top of the main frame rails. The roof bar must follow the contour of the roof as it bends across the front maintaining a minimum clearance to the top of the windshield. The center to center width of the roof bar (#3)

must be 49 inches, and a distance of 31-1/4 inches must be maintained from the centerline of the roof bar (#3) to the centerline of the main roll bar (#1). The forward roof bar (#3A) must be a continuous length of tubing extending from the top surface of front roll bar leg (#2A) at vertical vent window bar (#10A) to the top surface of front roll bar leg (#2B) at vertical vent window bar (#10B). The forward roof bar (#3A) must intersect the center windshield bar (#4A). The centerlines of vertical vent window bars (#10A & B) and forward roof bar (#3A) must be coplanar. The forward roof bar (#3A) must be bent at each end and at the center windshield bar (#4A) to aid in locating the bar as close to the windshield as possible.

4. The centerline roof bar (#4) must be a continuous length of tubing, extending from the main roll bar (#1) forward to the roof bar (#3) parallel to the vehicle's chassis longitudinal centerline. The centerline of roof bar (#4) must not be located to the left of the vehicle's chassis longitudinal centerline. The center windshield bar (#4A) must extend forward from the roof bar (#3) in line with centerline roof bar (#4), intersecting the forward roof bar (#3A), and bend downward following the back of the windshield with minimum clearance. The center windshield bar (#4A) must pass through the top of the dash panel and attach to a support bar under the dash panel at the firewall.
5. The main roll bar diagonal bar (#5) must form a straight line, with no bends, and must begin near the upper left bend of the main roll bar (#1) at the intersection of roof bar (#3) behind the driver's head and after intersecting the horizontal shoulder bar (#7), it must be welded to the lower right side of the main roll bar (#1) where the horizontal tunnel bar (#6) is welded to the main roll bar (#1).
6. Two (2) horizontal bars (#6 & #7) must each be a continuous length of tubing and must be welded, with no bends, inside the vertical legs of the main roll bar (#1) with the horizontal tunnel bar (#6) welded 7-1/2 inches on center above the main frame rail and the horizontal shoulder bar (#7) at 20-3/4 inches on center above the main frame rails. An additional shoulder belt bar (#7B) must be a continuous length of tubing and may be added above the horizontal shoulder bar (#7) to facilitate shoulder harness mounting height. The shoulder belt bar (#7B) must be welded to the main roll bar (#1) and the main roll bar diagonal bar (#5) or it may be a bent tube constructed of 1-3/4 inches by 0.090 inch minimum wall thickness steel, round tubing, meeting the ASTM A-519 specification, welded at each end to the horizontal shoulder bar (#7) to form a loop above the horizontal shoulder bar (#7). The shoulder belt bar (#7B) must not be forward of the plane of main roll bar (#1).
7. The diagonal bar (#7A) must be welded near the center of the horizontal shoulder bar (#7). The diagonal bar then extends forward to an intersection with the roof support bar (#12) and continues through the firewall. This diagonal bar must be welded to the right front sub-frame rearward of the spring bucket. This bar must be made from 1-3/4 inches outside diameter by 0.065 inch minimum wall thickness magnetic steel seamless round tubing.
8. The dash panel bar (#8) must be a continuous length of tubing, with no bends, welded beneath the dash panel between the two (2) front roll bar legs (#2 A & B) at a height of 22-1/4 inches on center above the main frame rail.
9. The door bars (#9 A & B), on both the left and right sides, must have a minimum of four (4) bars spaced from top to bottom that must be welded between the vertical uprights of the main roll bar (#1) and the front roll bar legs (#2 A & B). All door bars must each be a continuous length of tubing. The top door bar on each side must maintain a vertical height of 22-1/4 inches from the top of the main frame rail to its centerline at the front of the door bar, and it must maintain a vertical height of 20-3/4 inches from the top of the main frame rail to its centerline at the rear of the door bar. The top door bar on each side must match up with the intersection of the dash panel bar (#8) at the front roll bar legs (#2 A & B) at the front and the intersection of the horizontal shoulder bar (#7) at the main roll bar (#1) at the rear.

- a. Left Side Door Bars (#9A): All left side door bars must be convex in shape. The left side door bars must maintain vertical heights from the top of the main frame rail to the centerline of the door bar as follows:

Top left door bar (#9A-1):	22-1/4 inches at the front and 20 3/4 inches at the rear
Second left door bar (#9A-2):	17 inches at the front and 15 1/2 inches at the rear
Third left door bar (#9A-3):	11-1/2 inches at the front and 10 inches at the rear
Bottom left door bar (#9A-4):	5 inches at the front and 5 inches at the rear

The left side door bars must have six (6) vertical support bars with two (2) spaced between each door bar. The vertical support bars must be located 9-1/2 inches from the center of left front roll bar leg (#2A) to the center of each forward vertical support bar and 9-1/2 inches from the center of main roll bar (#1) to the center of each rearward vertical support bar. The intersection of each left side door bar located between the vertical support bars must be straight as viewed from the top and the side and must remain parallel to the frame's longitudinal centerline. The left side door bars must be located from the frame's longitudinal centerline to the center of the door bar tubing as follows:

- Top left door bar (#9A-1):** 32 inches from the longitudinal centerline of the frame to the center of the tubing
- Second left door bar (#9A-2):** 31 ½ inches from the longitudinal centerline of the frame to the center of the tubing
- Third left door bar (#9A-3):** 31 inches from the longitudinal centerline of the frame to the center of the tubing.
- Fourth left door bar (#9A-4):** 31 inches from the longitudinal centerline of the frame to the center of the tubing

An anti-intrusion plate constructed of magnetic sheet steel with a minimum thickness of 0.085 inch must be securely welded to the outside of the left side door bars. This anti-intrusion plate must fill the area between the horizontal centerlines of the top and bottom door bars, and the vertical centerlines of main roll bar (#1), and the left front roll bar leg (#2A), (see Diagram #2B, in the rear pages of the Rule Book).

To facilitate emergency removal of the left side door bars (#9A), the anti-intrusion plate must have six (6), 2-1/2 inch diameter holes cut in the anti-intrusion plate, with three (3) holes near each end of the plate in the following locations:

- The upper two (2) holes must be centered vertically between the left side door bars (#9A-1&2), at an on-center distance of three (3) inches from the center of the left front roll bar leg (#2A) and main roll bar (#1).
 - The middle two (2) holes must be centered vertically between the left side door bars (#9A-2&3), at an on-center distance of three (3) inches from the center of the left front roll bar leg (#2A) and main roll bar (#1).
 - The lower two (2) holes must be centered vertically between the left side door bars (#9A-3&4), at an on-center distance of five (5) inches from the center of the left front roll bar leg (#2A) and main roll bar (#1).
- b. **Right Side Door Bars (#9B):** The top, second from the top, and third from the top right side door bars, must be convex in shape. The bottom right side door bar must be straight. The right side door bars must maintain vertical heights from the top of the main frame rail to the centerline of the door bar as follows:

- Top right door bar (#9B-1):** 22 1/4 inches at the front and 20-3/4 inches at the rear
- Second right door bar (#9B-2):** 16 5/8 inches at the front and 15-1/4 inches at the rear
- Third right door bar (#9B-3):** 11 3/8 inches at the front and 9-7/8 inches at the rear
- Bottom right door bar (#9B-4):** 4 7/8 inches at the front and 4-7/8 inches at the rear

The right side door bars must have eight (8) vertical support bars with two (2) spaced between each door bar and two (2) spaced between the bottom right side door bar and the main frame rail. The

vertical support bars must be located 9-1/2 inches from the center of right front roll bar leg (#2B) to the center of each forward vertical support bar, and 9-1/2 inches from the center of main roll bar (#1) to the center of each rearward vertical support bar (see Diagram #3A, in the rear pages of the Rule Book). The intersection of each right side door bar located between the vertical support bars must be straight as viewed from the top and the side and must remain parallel to the frame's longitudinal centerline. The right side door bar must be located from the frame's longitudinal centerline to the center of the door bar tubing as follows:

Top right door bar (#9B-1): 32 inches from the longitudinal centerline of the frame to the center of the tubing

Second right door bar (#9B-2): 31-1/2 inches from the longitudinal centerline of the frame to the center of the tubing

Third right door bar (#9B-3): 31 inches from the longitudinal centerline of the frame to the center of the tubing

Bottom right door bar (#9B-4): 28 inches from the longitudinal centerline of the frame to the center of the tubing

10. The vertical vent window bars (#10 A & B) must each be a continuous length of tubing welded from the upper surface of the top door bars on the right side and left side to the front roll bar legs (#2 A & B). The vertical vent window bars (#10A & B) must be straight. The vertical vent window bars (#10 A & B) must be perpendicular to the top door bars (#9 A & B). The vertical vent window bars (#10 A & B) must be located 9-1/2 inches rearward of the front roll bar legs (#2 A & B), measuring center to center along the respective top door bar.
11. A foot compartment protection bar (#11) must be a continuous length of tubing extending from the left front roll bar leg (#2A), a minimum of 17 inches above the top surface of the left main frame rail and welded to the left side front sub-frame rail.
12. The roof support bar (#12) must be a continuous length of tubing, with no bends, that extends from the right front corner of the roof bar (#3) and down to the rear suspension crossmember, between the front drive shaft hoop assembly and the step for the exhaust pipe clearance. The roof support bar (#12) must be welded a maximum of 11-1/2 inches and a minimum of 7-1/2 inches inboard from the center of the right side of roof bar (#3) (see Diagram #2B, in the rear pages of the Rule Book). The center roof support bar (#12A) must be a continuous length of tubing, with no bends that extends from the intersection of roof bar (#3), centerline roof bar (#4) and center windshield bar (#4A) and down to front roll bar leg (#2B) at the intersection of diagonal bar (#17).
13. The rear support bars (#13 A & B) must be continuous lengths of tubing welded to the left and the right back side of the main roll bar (#1) near the roof panel at the top. They must extend to and be welded to the top of the rear sub-frame rail within one (1) inch of the rear edge of the fuel cell recessed well. The rear support bars (#13 A & B) must remain straight from end to end as viewed from the top and must be installed parallel to the chassis longitudinal centerline. The rear support bars (#13A & B) must remain straight, when viewed from the side, from the top end to the welded intersection of trunk reinforcement bar (#14). One (1), minimum 1-1/2 inch diameter by 0.083 inch thick round or minimum 1-1/2 inch by 1-1/2 inch by 0.083 inch thick square, tubular welded support must be installed to connect the top surface of the rear sub-frame rails above the rear axle housing to the respective rear support bars (#13A & B). The tubular supports must connect to bars #13A & B, at a location directly above the three (3) inch rear axle tube and must connect to the top of the rear sub-frame rails no further forward than the center of the rear jacking bolt crossmember.
14. The trunk reinforcement bar (#14) must be a continuous length of tubing forming a loop directly above the rear sub-frame side rails and the rearmost crossmember and be welded to the rear support bars (#13 A & B). The trunk reinforcement bar (#14) must maintain a height of 5-3/4 (+/- 1/8) inches from the top of the rear crossmember to the trunk reinforcement bar's (#14) center. The trunk reinforcement bar (#14) must remain parallel to the rear sub-frame rear side rails and rear crossmember.

15. Three (3) evenly spaced rear vertical support bars (#15) must be welded perpendicular to the top of the rear crossmember and to the bottom surface of the trunk reinforcement bar (#14).
16. The two (2) front sub-frame bars (#16 A & B) must each be a continuous length of tubing welded to the right side and the left side of the front roll bar legs (#2 A & B) at a height of 22-1/4 inches from the top of the main frame rail to the centerline of the two (2) front sub-frame bars (#16A&B). Bending of front sub-frame bars (#16A & 16B) rearward of the front firewall will not be permitted. The front sub-frame bars (#16 A & B) must extend forward through the firewall. The front sub-frame bars (#16A & B) must be a minimum height of 25-1/2 inches, measured from the surface plate to the center of the roll bar at chassis coordinate location -59X (59 inches forward of the back of the trailing arm crossmember). Front sub-frame bars (#16A & B) must bend down, using one (1), large radius, bend only, and must be welded to the front sub-frame rails forward of the spring buckets near the radiator mount.

Support tubes, connecting front sub-frame bars (#16A & B) to the front sub-frame rails, rearward of the front spring buckets, must be completely welded in place at both ends.

Support tubes, connecting front sub-frame bars (#16A & B) to the front sub-frame assembly at or forward of the front spring buckets, may be welded in place or removable.

All removable support tubes and tubes that connect front sub-frame bars (#16A & B) to each other (Bay Bars), or to the front sub-frame assembly at or forward of the front spring buckets, must be submitted for approval when materials other than magnetic steel tubing are used.

17. A diagonal bar (#17), using a continuous length of tubing, to support dash panel bar (#8), must be welded near the center of dash panel bar (#8) and to the right front roll bar leg (#2B) near the top of the right main frame rail.
18. The two (2) rear sub-frame outer support bars (#18A & B) must each be a continuous length of tubing welded between the rear sub-frame rails and the back of main roll bar (#1) at a vertical height of 20-3/4 inches from the top of the main frame rail to the center of the rear sub-frame outer support bars (#18A & B). Rear sub-frame outer support bars (#18A & B) must be made from 1-3/4 inches outside diameter by 0.049 inch minimum wall thickness magnetic steel, seamless, round tubing.
19. The two (2) rear sub-frame inner support bars (#19A & B) must each be a continuous length of tubing welded at or near the rear sub-frame rails and the back of the horizontal shoulder bar (#7) near the center of the roll cage. Rear sub-frame inner support bars (#19A & B) must be made from 1-3/4 inches outside diameter by 0.049 inch minimum wall thickness magnetic steel, seamless, round tubing.

C. Gussets

1. Gussets must be used at the intersection where the main roll bar (#1) and the right front roll bar leg (#2B) meet the right side main frame rail, and the gussets must be constructed using a minimum one (1) inch wide by two (2) inches high by 0.059 inch thick, magnetic steel box tubing.
2. Solid gussets must be used at the intersection where the front roll bar legs (#2A & B) intersect the roof bar (#3) and the upper side of forward roof bar (#3), and the gussets must be constructed from a minimum 0.095 inch thick triangular-shaped magnetic steel flat plate measuring a minimum of 1-1/2 inches long on each side that is to be welded.
3. Solid gussets must be used at the intersection of main roll bar (#1) and the front roll bar leg (#2B) with door bars (#9B) and the gussets must be constructed from a minimum 0.095 inch thick triangular-shaped magnetic steel flat plate measuring a minimum of 1-1/2 inches long on each side that is to be welded.
4. Solid gussets must be used at the intersection of main roll bar (#1), roof bar (#3) and rear support bars (#13A & B). The gussets must be constructed from a minimum of 0.095 inch thick triangular-shaped magnetic steel flat plate measuring a minimum of 1-1/2 inches long on each side that is to be welded. A solid gusset must be used at the intersection of center roof support bar (#12A) and roof bar (#3).
5. Holes and/or other modifications to roll bar gussets that, in the judgment of ARCA Officials, have been made with the intent of weight reduction will not be permitted.

D. For the approved location of the various roll bars, please reference the roll cage Diagrams #2A-C & #3A-B, in the rear pages of the Rule Book.

E. Modifications to the NASCAR-approved roll cage design described above must be submitted in blueprint and/or computer aided design (CAD) files for acceptance to the NASCAR R&D Center in Concord, North Carolina at least 60 days before the design can be entered in competition. If ARCA Officials accepts

the modification as set forth in the submitted files, the Competitor must submit for inspection a completed frame and roll cage at least 30 days prior to the date of intended competition. Acceptance of the submitted blueprint and/or computer aided design (CAD) file does not guarantee acceptance of the completed frame and roll cage design, and ARCA Officials may decide not to accept such design even if it is the same as the submitted file. If ARCA Officials accepts the completed frame and roll cage, it may then be used in competition in the form accepted, unless and until the form is no longer approved by ARCA Officials.

F. All roll bars within the driver's reach must be covered with an impact absorbent material manufactured to the SFI 45.1 specification and be acceptable to ARCA Officials. Impact absorbent material used on roll bars must meet SFI 45.1 specifications and be imprinted on the outside surface with the SFI logo.

G. Roll bar padding must be symmetrically positioned between the centerline of the roll bar to which it is mounted and the nearest portion of the drivers body.

H. All roll bar padding must be adhered to the roll bar with adhesive or double-sided tape.

I. All references to the roll cage, roll bars, roll cage bars or the roll cage bar design specified in other sub-sections of the Rule Book refer to sub-section 20C-18.

J. At the discretion of ARCA Officials, additional material and/or tubing may be required to be welded to any vehicle that does not conform to the roll cage or roll bar specifications as described in sub-section 20C-18.

CONSTRUCTION GUIDELINES

DIAGRAM #1 - TYPICAL ARCA FRAME (PLAN VIEW)

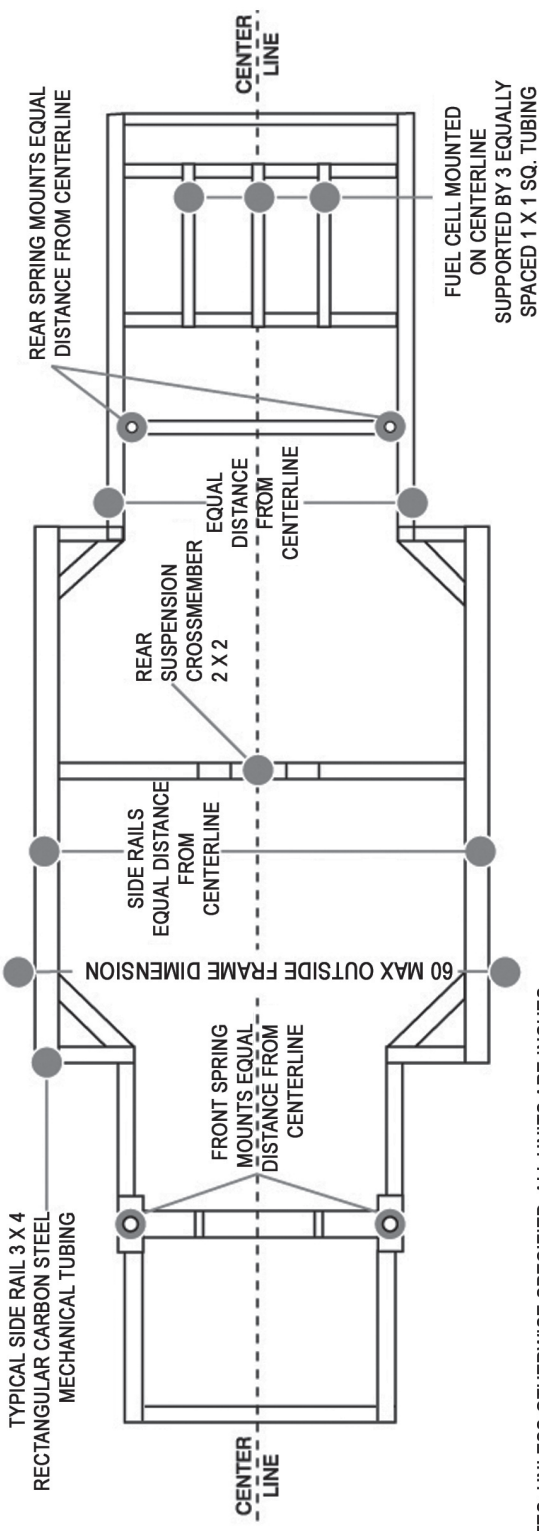

NOTES: UNLESS OTHERWISE SPECIFIED, ALL UNITS ARE INCHES.

DIAGRAM #1A FRAME (GEN 5)

NOTES:

* TYPICAL PARTS AND DIMENSIONS WHERE CONFIGURATION VARIATIONS WITHIN THE RULES WILL BE ALLOWED.

FUEL CELL WELL
20C-16.3

ALL "X" COORDINATES USE THE CENTER CONICAL RECEIVER IN THE TRUCK ARM CROSSMEMBER WITH A ONE (1) INCH OFFSET AS "0" (ZERO).
ALL "Y" COORDINATES USE THE LONGITUDINAL CENTERLINE OF THE CHASSIS AS "0" (ZERO).
ALL "Z" COORDINATES USE THE INSPECTION SURFACE AS "0" (ZERO).
UNLESS OTHERWISE SPECIFIED, ALL UNITS ARE INCHES.

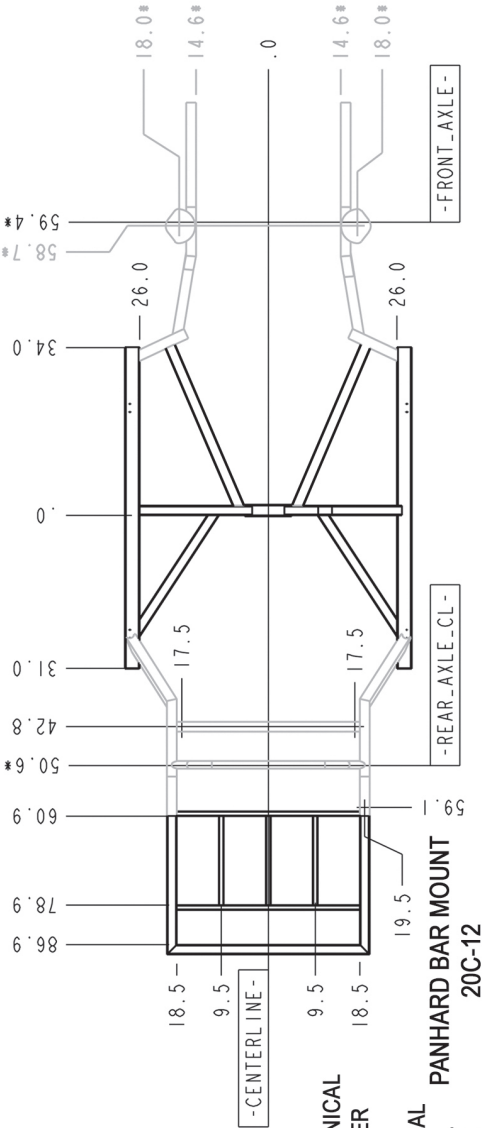

DIAGRAM #1B FRAME (GEN 5)

NOTES:

* TYPICAL PARTS AND DIMENSIONS WHERE CONFIGURATION VARIATIONS WITHIN THE RULES WILL BE ALLOWED.

NOTES:

ALL "X" COORDINATES USE THE CENTER CONICAL RECEIVER IN THE TRUCK ARM CROSSMEMBER WITH A ONE (1) INCH OFFSET AS "0" (ZERO).

ALL "Y" COORDINATES USE THE LONGITUDINAL CENTERLINE OF THE CHASSIS AS "0" (ZERO).

ALL "Z" COORDINATES USE THE INSPECTION SURFACE AS "0" (ZERO). UNLESS OTHERWISE SPECIFIED, ALL UNITS ARE INCHES.

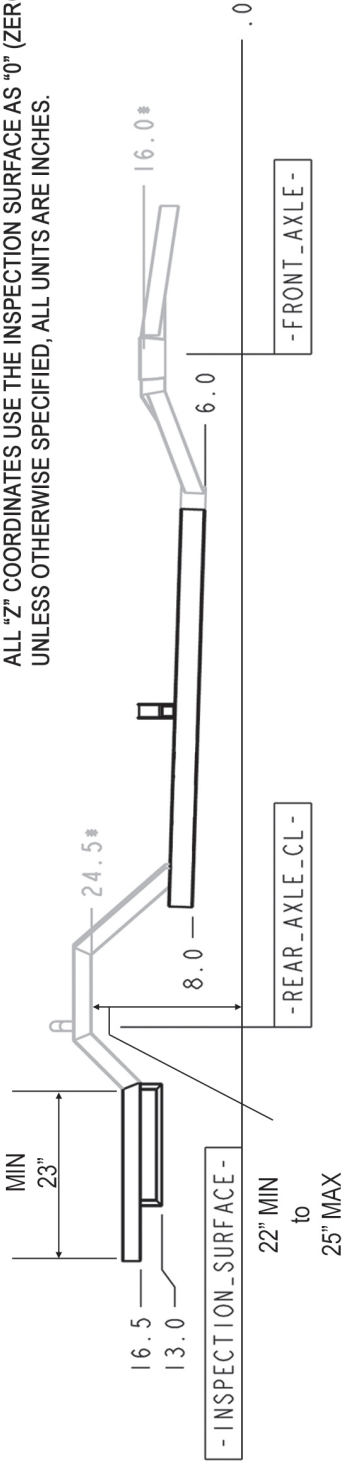
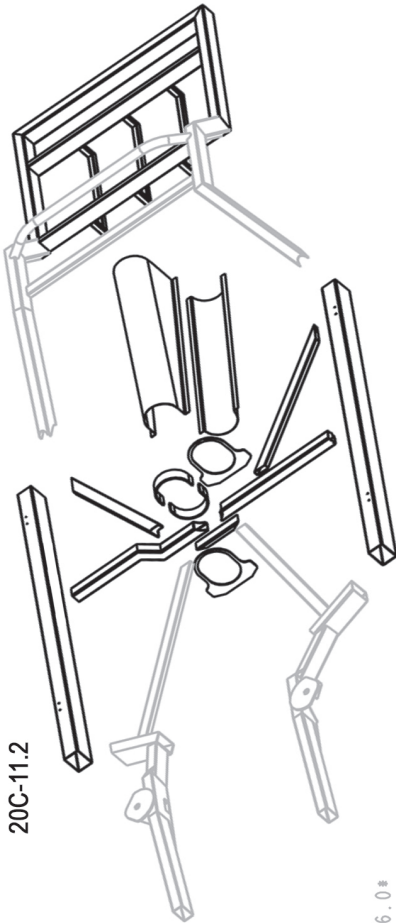

DIAGRAM #1C FRAME (GEN 5)

NOTES:

- * TYPICAL PARTS AND DIMENSIONS WHERE CONFIGURATION VARIATIONS WITHIN THE RULES WILL BE ALLOWED.
- ALL "X" COORDINATES USE THE CENTER CONICAL RECEIVER IN THE TRUCK ARM CROSSMEMBER WITH A ONE (1) INCH OFFSET AS "0" (ZERO).
- ALL "Y" COORDINATES USE THE LONGITUDINAL CENTERLINE OF THE CHASSIS AS "0" (ZERO).
- ALL "Z" COORDINATES USE THE INSPECTION SURFACE AS "0" (ZERO).
- UNLESS OTHERWISE SPECIFIED, ALL UNITS ARE INCHES.

DRIVESHAFT HOOP
20C-11.2



DRIVESHAFT TUNNEL
20C-3.4

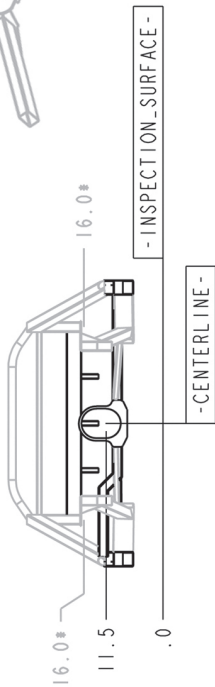
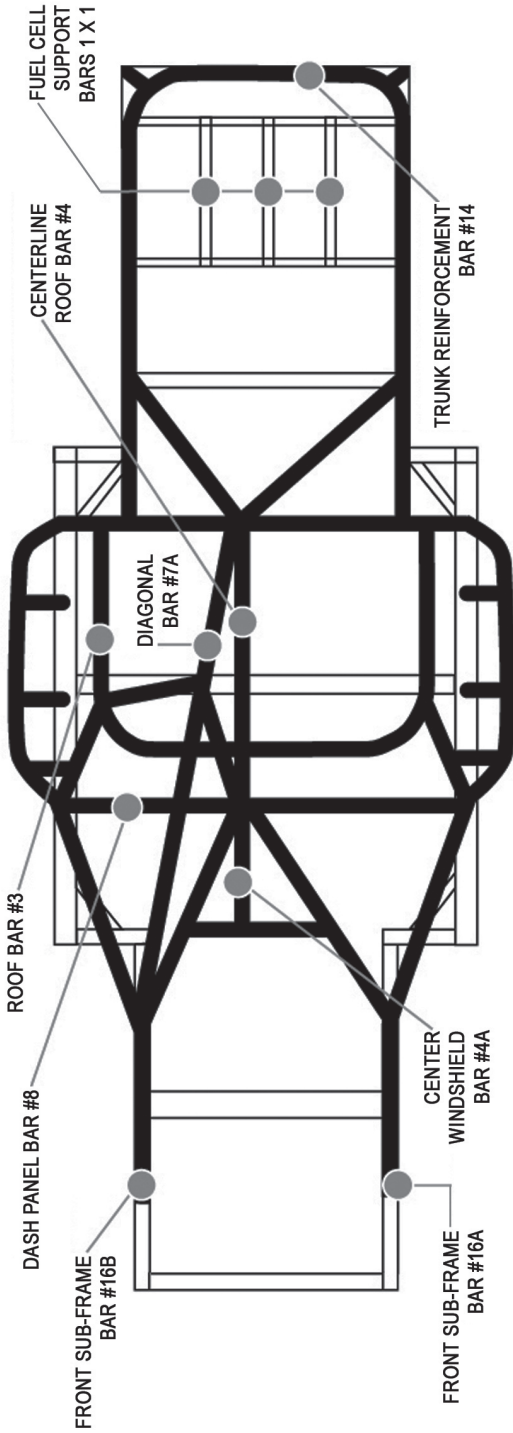

DIAGRAM #2 - TYPICAL ROLL CAGE AND FRAME CONSTRUCTION (PLAN VIEW)



NOTES: UNLESS OTHERWISE SPECIFIED, ALL UNITS ARE INCHES.

DIAGRAM #2A ROLL CAGE STRUCTURE (GEN 5)

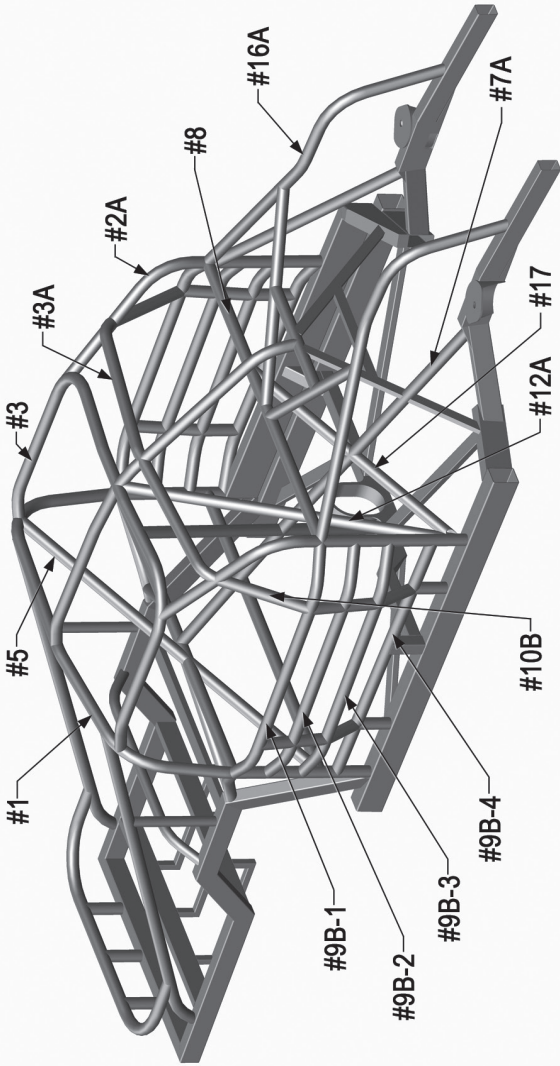

DIAGRAM #2B ROLL CAGE STRUCTURE (GEN 5)

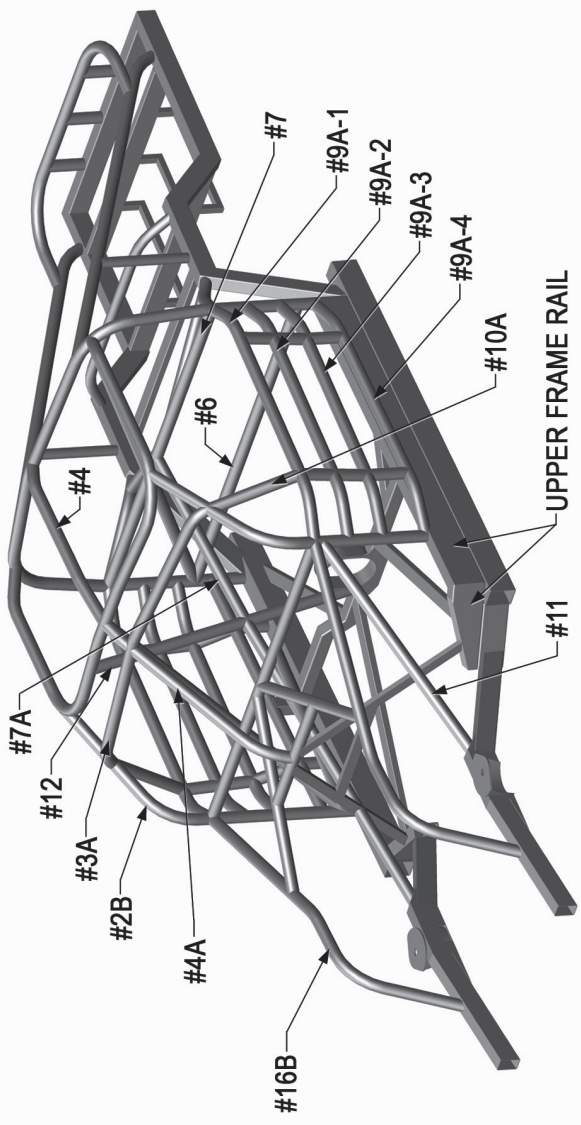

DIAGRAM #2C ROLL CAGE STRUCTURE (GEN 5)

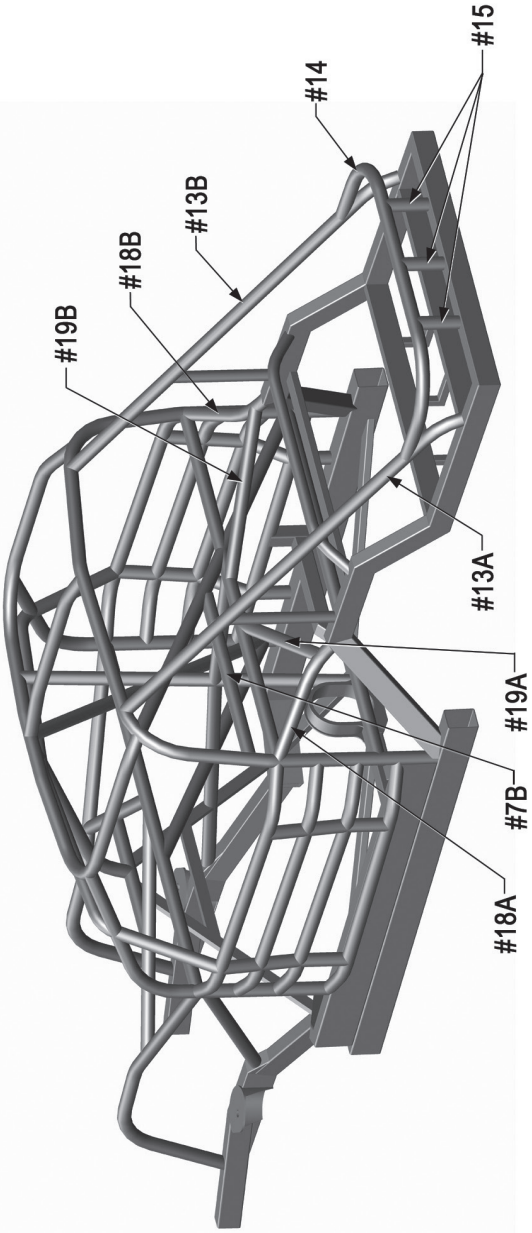
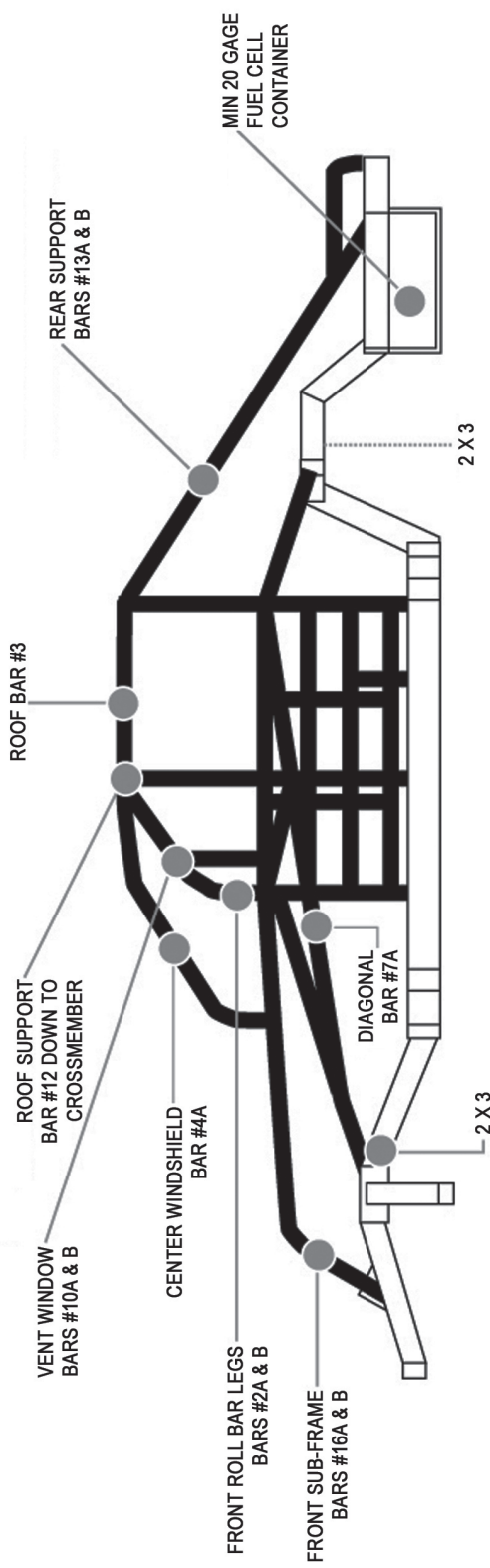

DIAGRAM #3 - TYPICAL ROLL CAGE AND FRAME CONSTRUCTION (SIDE VIEW)



NOTES: UNLESS OTHERWISE SPECIFIED, ALL UNITS ARE INCHES.

DIAGRAM #3A (GEN 5)

NOTES:

ALL "X" COORDINATES USE THE CENTER CONICAL RECEIVER IN THE TRUCK ARM CROSSMEMBER WITH A ONE (1) INCH OFFSET AS "0" (ZERO).

ALL "Y" COORDINATES USE THE LONGITUDINAL CENTERLINE OF THE CHASSIS AS "0" (ZERO).

ALL "Z" COORDINATES USE THE INSPECTION SURFACE AS "0" (ZERO).
UNLESS OTHERWISE SPECIFIED, ALL UNITS ARE INCHES.

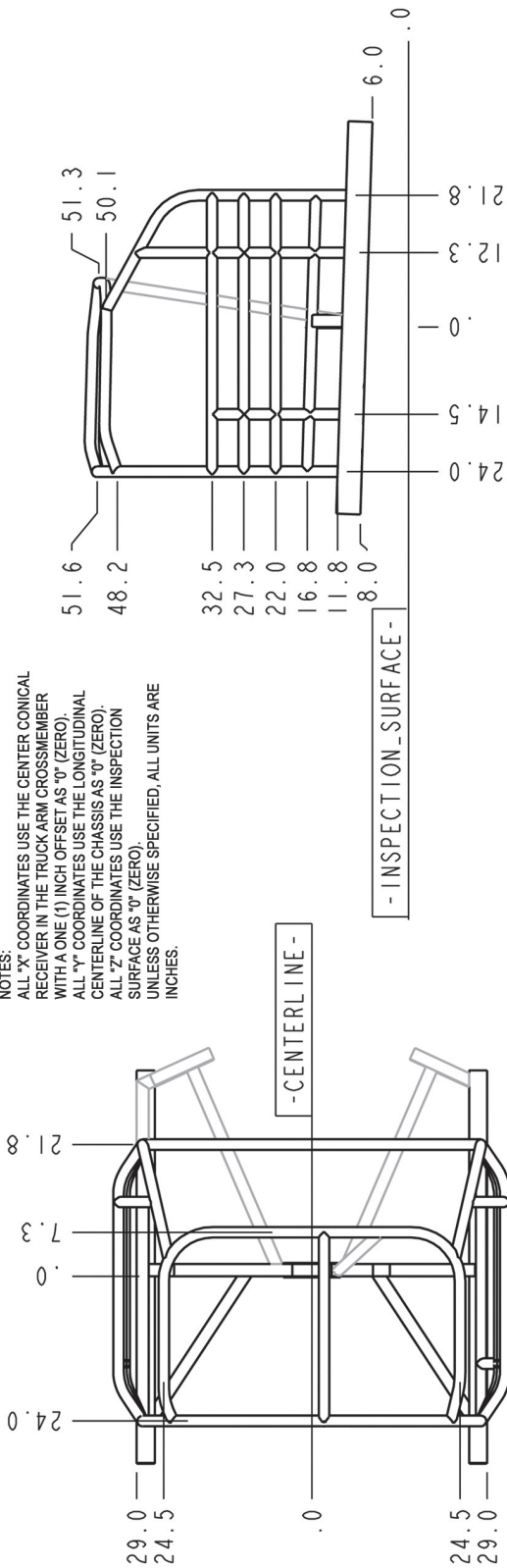
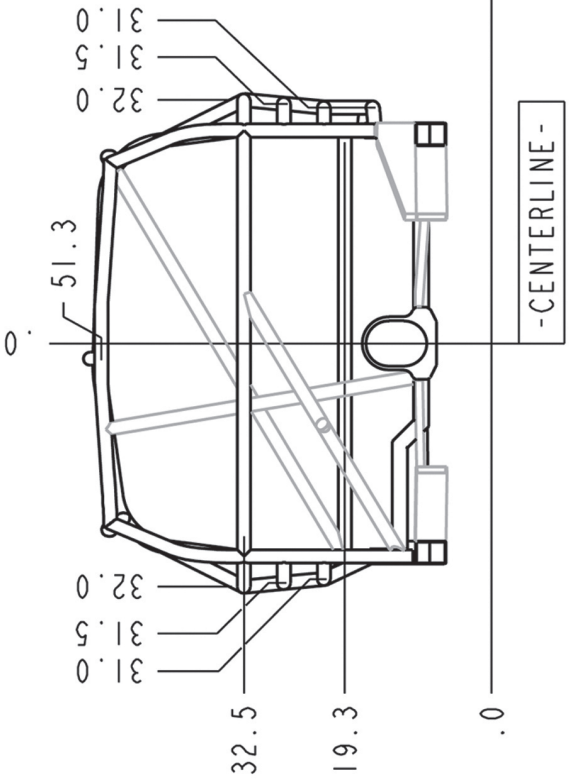

DIAGRAM #3B (GEN 5)



NOTES:

ALL "X" COORDINATES USE THE CENTER CONICAL RECEIVER IN THE TRUCK ARM CROSSMEMBER WITH A ONE (1) INCH OFFSET AS "0" (ZERO).

ALL "Y" COORDINATES USE THE LONGITUDINAL CENTERLINE OF THE CHASSIS AS "0" (ZERO).

ALL "Z" COORDINATES USE THE INSPECTION SURFACE AS "0" (ZERO).

UNLESS OTHERWISE SPECIFIED, ALL UNITS ARE INCHES.

DIAGRAM #4 - EXPLODED VIEW OF BASIC ROLL CAGE

(SOME BARS REMOVED FOR CLARITY)

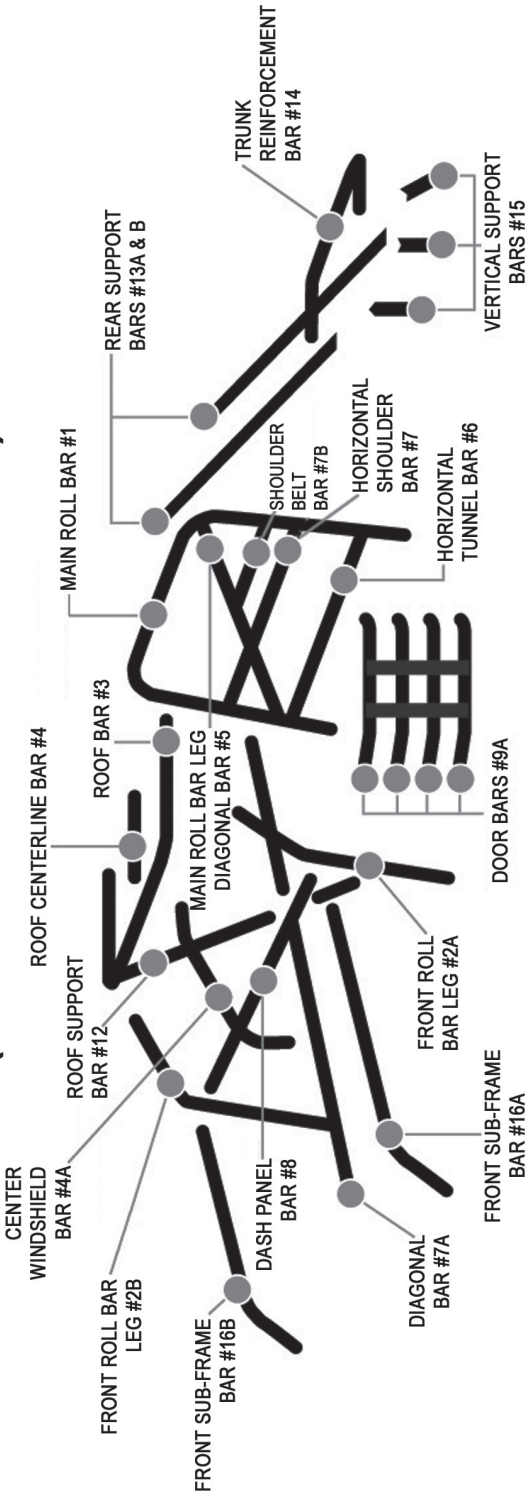

DIAGRAM #4A - BASIC ROLL CAGE STRUCTURE

(SOME BARS REMOVED FOR CLARITY)

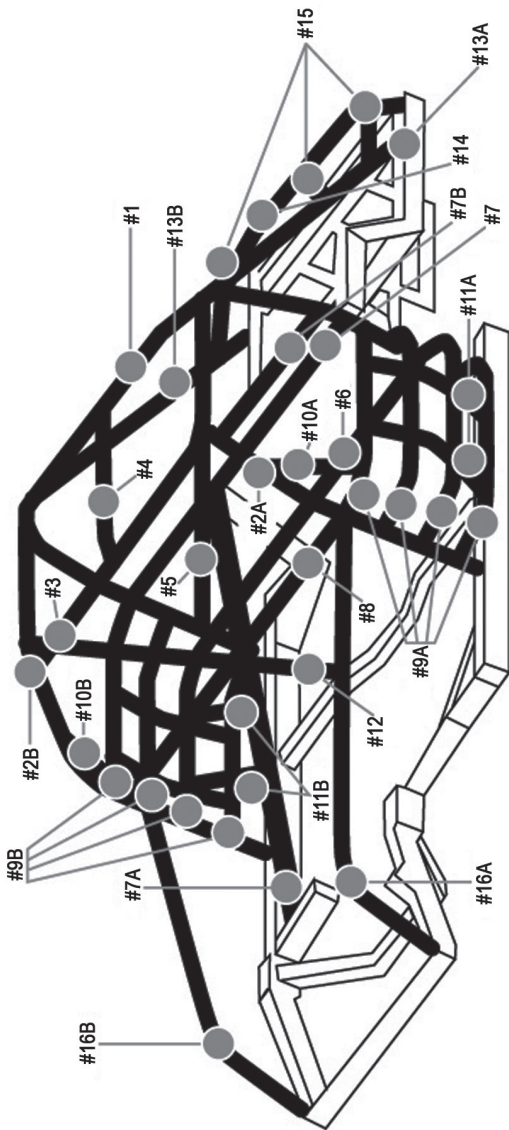

DIAGRAM #5A (GEN 5)

NOTES:
 ALL "X" COORDINATES USE THE CENTER CONICAL RECEIVER IN THE TRUCK ARM CROSSMEMBER WITH A ONE (1) INCH OFFSET AS "0" (ZERO).
 ALL "Y" COORDINATES USE THE LONGITUDINAL CENTERLINE OF THE CHASSIS AS "0" (ZERO).
 ALL "Z" COORDINATES USE THE INSPECTION SURFACE AS "0" (ZERO).
 UNLESS OTHERWISE SPECIFIED, ALL UNITS ARE INCHES.

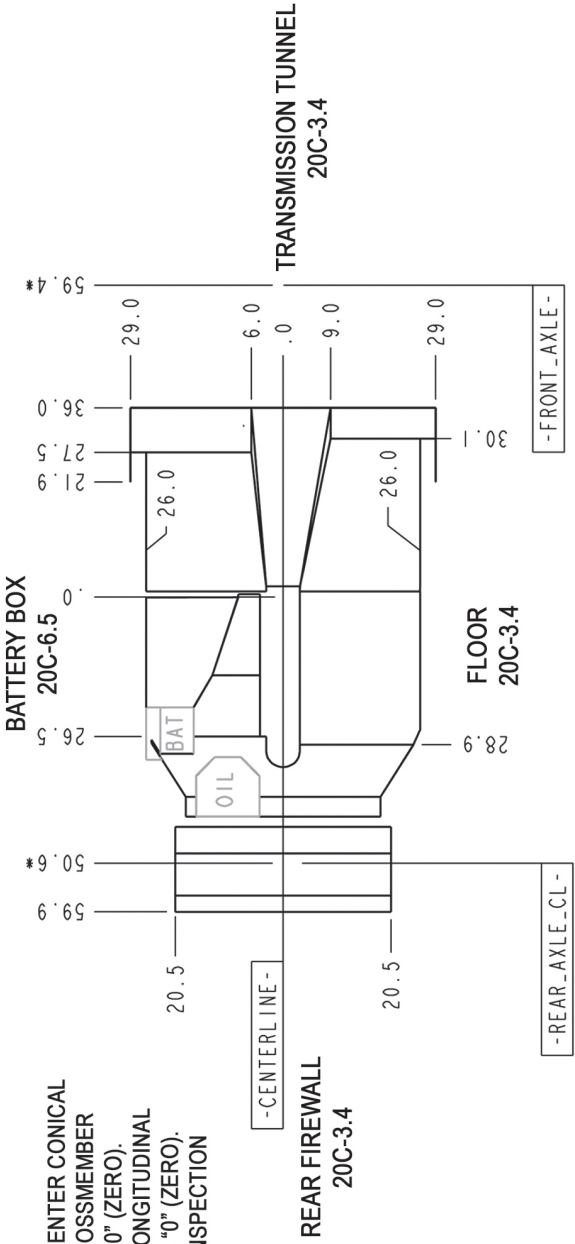

DIAGRAM #5B (GEN 5)

NOTES:

- ALL "X" COORDINATES USE THE CENTER CONICAL RECEIVER IN THE TRUCK ARM CROSSMEMBER WITH A ONE (1) INCH OFFSET AS "0" (ZERO).
 - ALL "Y" COORDINATES USE THE LONGITUDINAL CENTERLINE OF THE CHASSIS AS "0" (ZERO).
 - ALL "Z" COORDINATES USE THE INSPECTION SURFACE AS "0" (ZERO).
- 20C-3.4
20C-3.4
- UNLESS OTHERWISE SPECIFIED,
ALL UNITS ARE INCHES.

OIL TANK ENCASUREMENT 20C-3.4

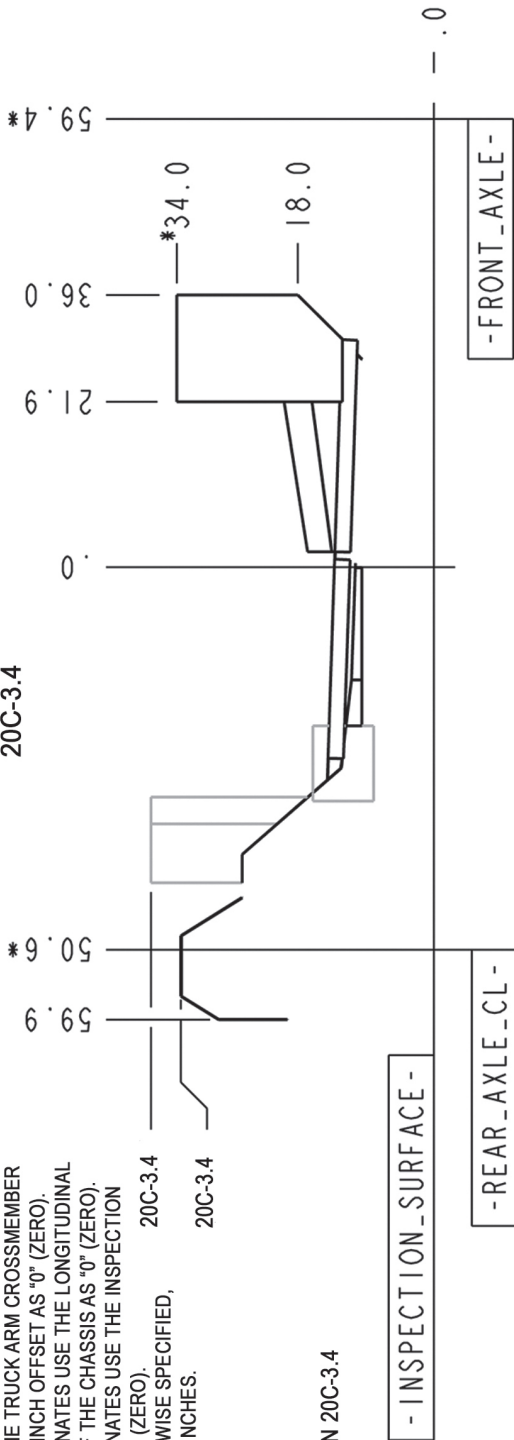
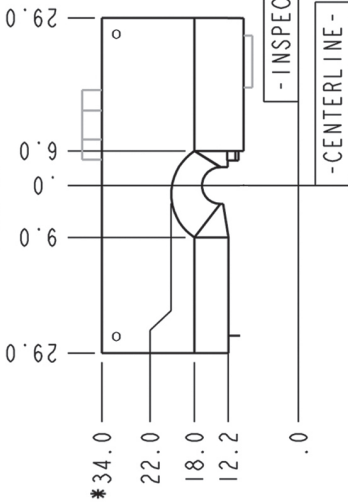

DIAGRAM #5C (GEN 5)

FRONT FIREWALL

20C-3.4



NOTES:

- ALL "X" COORDINATES USE THE CENTER CONICAL RECEIVER IN THE TRUCK ARM CROSSMEMBER WITH A ONE (1) INCH OFFSET AS "0" (ZERO).
- ALL "Y" COORDINATES USE THE LONGITUDINAL CENTERLINE OF THE CHASSIS AS "0" (ZERO).
- ALL "Z" COORDINATES USE THE INSPECTION SURFACE AS "0" (ZERO).
- UNLESS OTHERWISE SPECIFIED, ALL UNITS ARE INCHES.

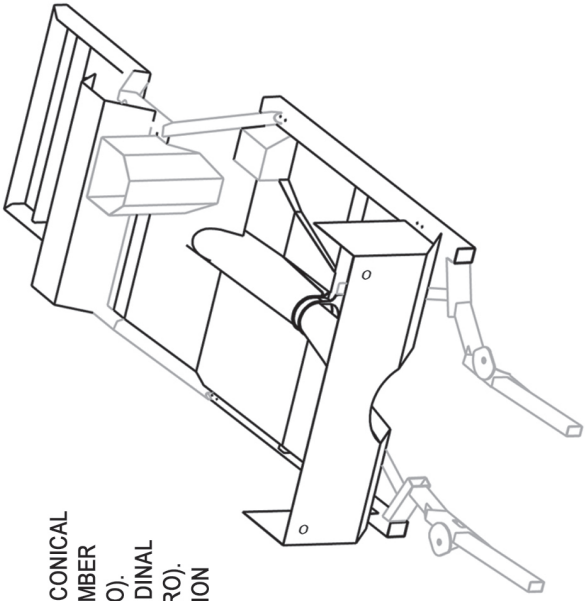

* SEE SECTION 20C-3.4

GRAND NATIONAL-APPROVED (Flange Fit) COMPOSITE BODY MOUNTING INSTRUCTIONS

The following Grand National-Approved (Flange Fit) Composite Body mounting instructions are to be used with Diagrams (#8A & B). To use these instructions, the numbered paragraphs each relate to corresponding numbers shown in Diagrams (#8A & B). Each paragraph explains the requirements for the mounting of the Grand National-Approved (Flange Fit) Composite Body.

1. The body must be mounted on the chassis centerline from front to rear with no offset. The body must remain as manufactured with no modifications.
2. The body location when measured horizontally rearward from the center of the roof at the divot to the vertical centerline of the rear axle housing must be 49 inches plus or minus (+/-) 1/2 inch for all 110 inch wheelbase cars and 45 inches plus or minus (+/-) 1/2 inch for all 105 inch wheelbase cars.
3. The greenhouse must be mounted to the roll cage using the mounting points provided in the greenhouse. The greenhouse must be mounted to the roll cage using braces constructed of 3/8 inch minimum diameter magnetic steel tubing. The roof braces may be adjustable (heim joint or slotted) on one end, the opposite end must be fixed with no adjustment. The front cowl must be attached to the leading edge of the dash. The rear panel (package tray) must be attached to the interior sheet metal.
4. The body mounting points must incorporate the hood hinges and rear deck lid hinges. The body mounts must use a 1/8 inch minimum thick magnetic steel plate mounted underneath the body and connected to the front sub-frame bars (#16A & B) on the front and connected in the rear to support bars (#13A & B) with braces constructed of 3/8 inch minimum diameter magnetic steel tubing using 10/32 inch minimum diameter flush mounting bolts.
5. The front bumper cover must be installed with a brace constructed of 3/8 inch minimum diameter magnetic tubing that follows the shape of the front bumper cover where the leading edge of the hood meets the front bumper cover. The brace must be mounted underneath the upper edge of the front bumper cover using 10/32 inch minimum diameter flush mounting bolts or pop-riveted to the brace. The brace must be connected to the front sub-frame bars (#16A & B) and the front sub-frame or front bumper mounting bars with 3/4 inch minimum diameter tubing. The lower edge of the front bumper cover must be connected to the front bumper or lower bumper cover braces with either 10/32 inch minimum diameter flush mounting bolts or pop-riveted.
6. The upper rear of the quarter panels must be installed using a minimum 1/8 inch thick magnetic steel plate mounted underneath the rear quarter panels. The outer edges of the mounting plate must be connected to the rear quarter panels under the inner edge of the quarter panel using 10/32 inch minimum diameter flush mounting bolts or pop-riveted. The mounting plate must be connected to either the trunk reinforcement bar (#14) or to the rear crossmember using 3/8 inch minimum diameter tubing. The rear bumper cover must be installed with a brace constructed of 3/8 inch minimum diameter tubing that follows the shape of the rear bumper cover where the deck lid waterfall meets the rear bumper cover. The brace must be mounted underneath the upper edge of the rear bumper cover using 1/4 inch diameter flush mounting bolts or pop riveted to the brace. The brace must be connected to either the trunk reinforcement bar (#14) or the rear crossmember with a minimum of two (2) supports using a minimum of 1/4 inch solid round magnetic steel rod. The lower edge of the rear bumper cover must be connected to the rear bumper with either 10/32 inch minimum diameter flush mounting bolts or pop-riveted.
7. The flange fit front fenders, door panels and rear quarter panels must be connected to the chassis and greenhouse using only 10/32 inch minimum diameter flush mounting bolts, pop rivets will not be permitted. The body panel flanges must be connected using only 10/32 inch minimum diameter mounting bolts and 1/2 inch minimum outside diameter washers, pop rivets will not be permitted. The braces may be adjustable on one end (heim joint or slotted), the opposite end must be fixed with no adjustment. The body mounting braces and locations must be acceptable to ARCA Officials.

8. The lower side of the body must be mounted to the rocker panel. The rocker panel must extend from the bottom of the main frame rail outward to the inside edge of the body and must have a 90 degree bend upward a minimum of 1-1/2 inches and bend inward a minimum of 1/2 inch. The rocker panel must be installed the full length of the side from wheel opening to wheel opening. The rocker panel must be a minimum of 24 gage (0.025 inch thick) magnetic sheet steel. The body must attach to the rocker panel using a minimum of eight (8) 10/32 inch minimum diameter flush mounting bolts evenly spaced from front to rear.
9. All additional body mounting braces and locations must be acceptable to ARCA Officials

The Grand National-Approved (Flange Fit) Composite Body must meet all other specifications as set forth in Section 20C of the ARCA Rule Book. All body mounting requirements must be acceptable to ARCA Officials.

DIAGRAM #6A (FLANGE FIT) COMPOSITE BODY MOUNTING INSTRUCTIONS

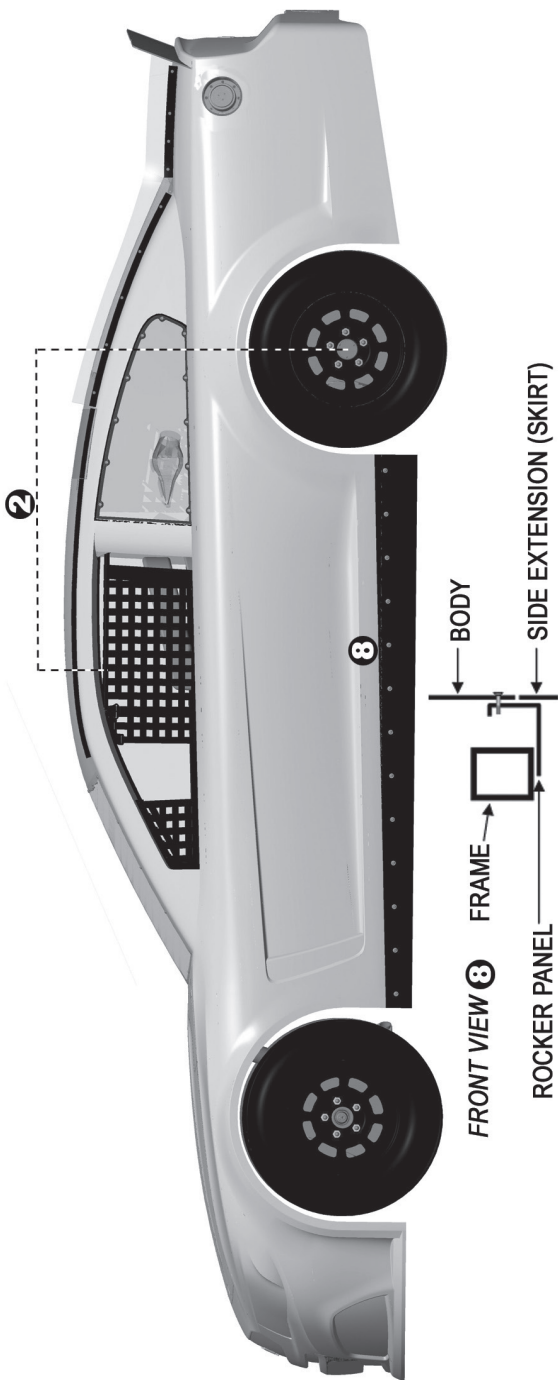
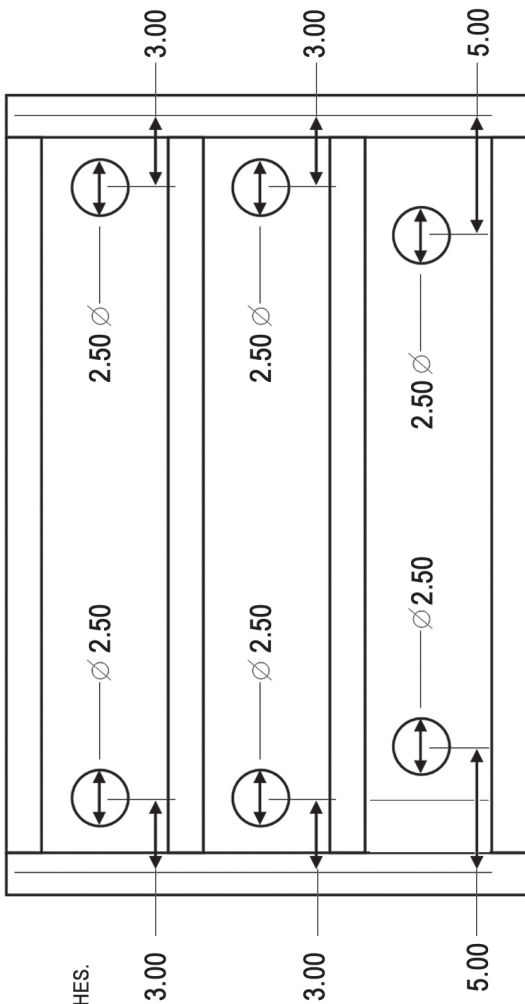

DIAGRAM #6B (FLANGE FIT) COMPOSITE BODY MOUNTING INSTRUCTIONS



DIAGRAM #7 ANTI-INTRUSION PLATE HOLE LOCATION

NOTES: UNLESS OTHERWISE SPECIFIED, ALL UNITS ARE INCHES.



VERTICAL BAR 2A

VERTICAL BAR 1

DIAGRAM #8A UPPER SEAT BACK MOUNTING BRACKET (ABTS)

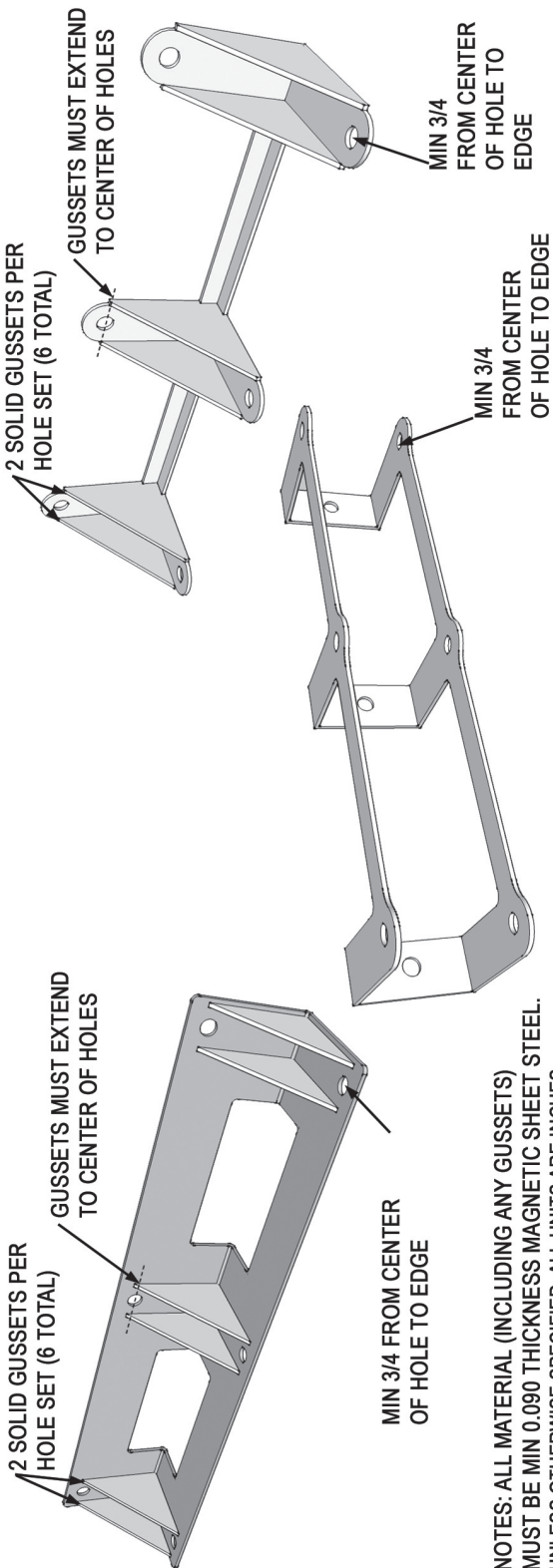

NOTES: ALL MATERIAL (INCLUDING ANY GUSSETS) MUST BE MIN 0.090 THICKNESS MAGNETIC SHEET STEEL. UNLESS OTHERWISE SPECIFIED, ALL UNITS ARE INCHES.

DIAGRAM #8B UPPER SEAT BACK MOUNTING BRACKET

SABELT

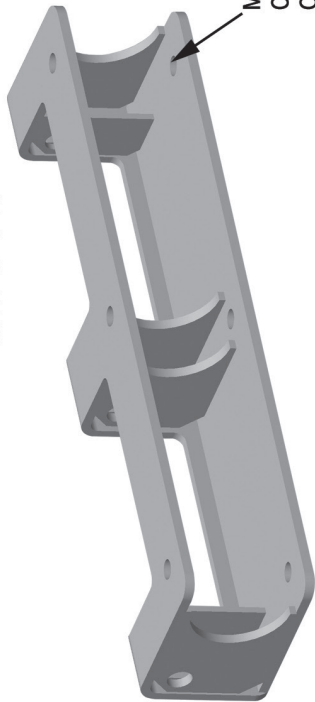

SPARCO

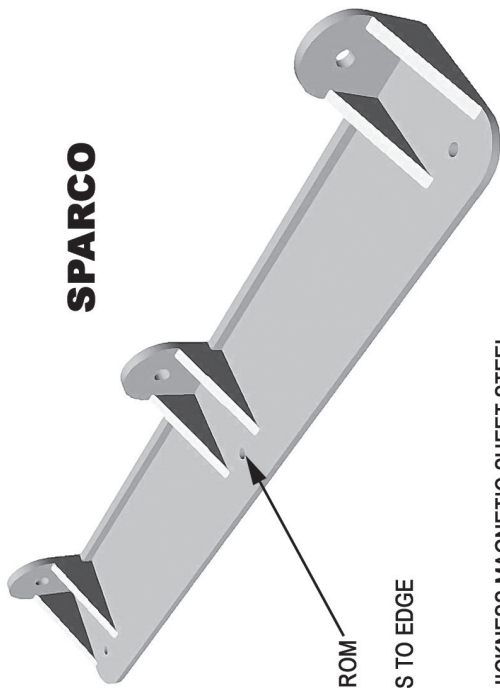

MIN 3/4 FROM
CENTER
OF HOLES TO EDGE

NOTES: ALL MATERIAL MUST BE MIN 3/16 THICKNESS MAGNETIC SHEET STEEL.
UNLESS OTHERWISE SPECIFIED, ALL UNITS ARE INCHES.

DIAGRAM #8C (ABTS) ALL BELTS TO SEAT MOUNTING

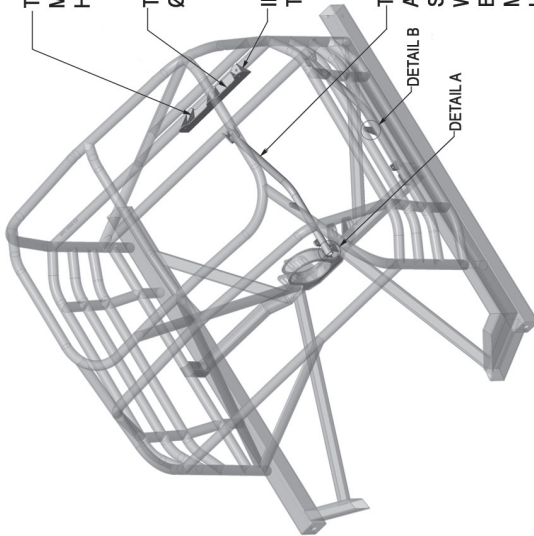

THE UPPER SEAT BRACKET MUST BE SECURED TO HORIZONTAL SHOULDER BAR #7 WITH MIN. (3) HIGH QUALITY \varnothing 5/16 MIN. MAGNETIC STEEL HEX HEAD BOLTS THROUGH THE HORIZONTAL SHOULDER BAR #7

THE UPPER SEAT BRACKET MUST BE FASTENED TO THE SEAT WITH A MIN. OF (3) HIGH QUALITY \varnothing 5/16 MIN. MAGNETIC STEEL BOLTS

IF USING A ABTS (ALL BELTS TO SEAT) SEAT, THE UPPER SEAT BRACKET MUST BE CONSTRUCTED PER DIAGRAM 8A

THE TUBULAR FRAME MUST BE CONSTRUCTED FROM ROUND MAGNETIC SHEET STEEL TUBING WITH A \varnothing 1.25 AND .088 MIN. WALL THICKNESS. IF USING A ABTS (ALL BELTS TO SEAT) SEAT, THE TUBULAR SEAT FRAME MUST BE CONSTRUCTED FROM ASTM A513 TYPE 5 ROUND MAGNETIC STEEL TUBING WITH A \varnothing 1.25 AND .15 MIN. WALL THICKNESS. THE TUBULAR SEAT FRAME MUST BE SECURED AT EACH END IN A DOUBLE SHEAR FASHION OR MUST BE SECURELY WELDED AT EACH END. IF WELDED, A GUSSET MUST BE USED AT EACH END. IF USING TUBULAR SEAT FRAME BRACKETS, THE SEAT FRAME MUST HAVE WELDED BUNGS WITH \varnothing 3/8 I.D.

ISO VIEW
SEATS - INSTALLATION

DIAGRAM #8D (ABTS) ALL BELTS TO SEAT MOUNTING

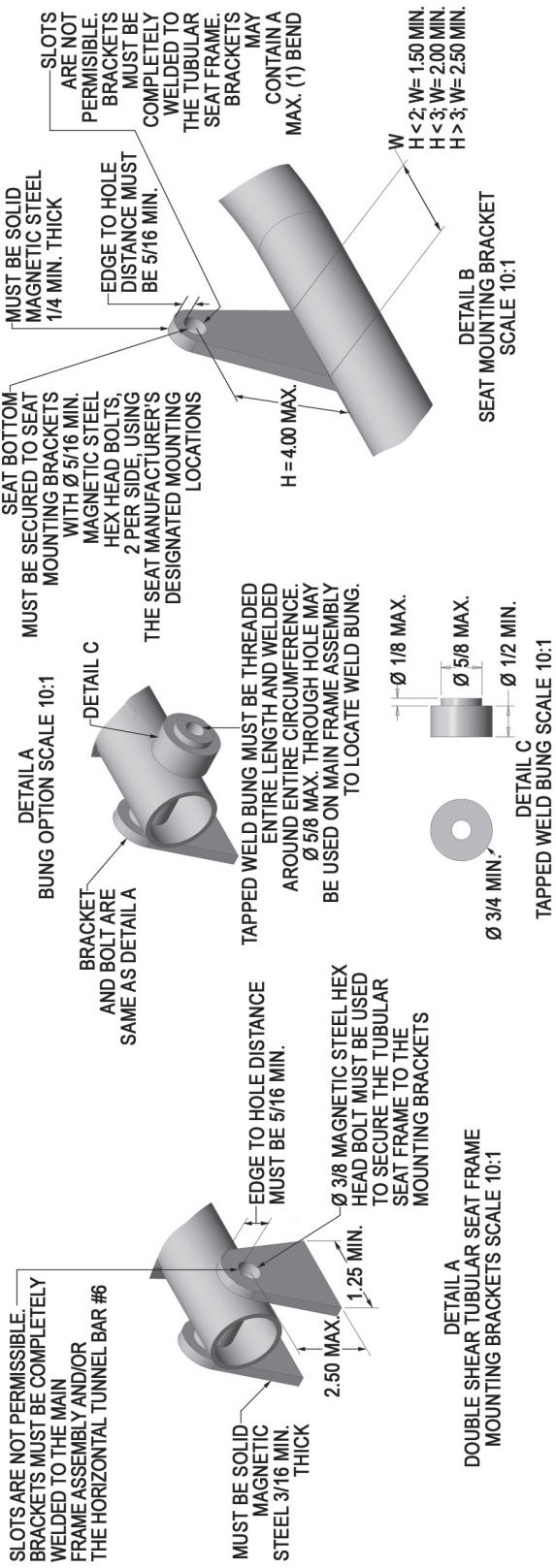
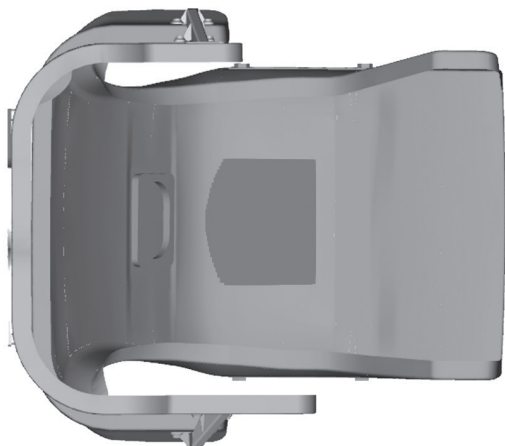
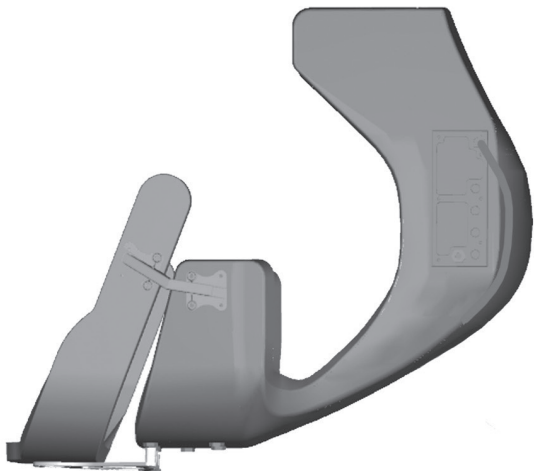

DIAGRAM #9 - SEAT PADDING

TOP VIEW



SIDE VIEW



FRONT VIEW

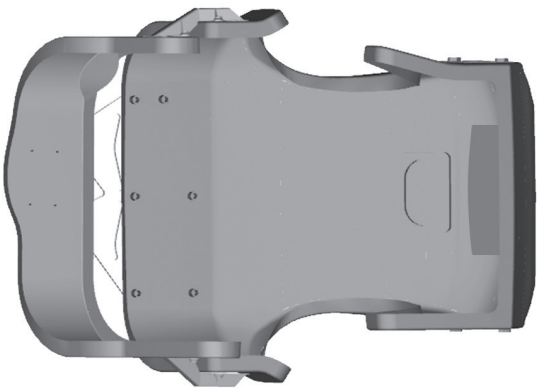
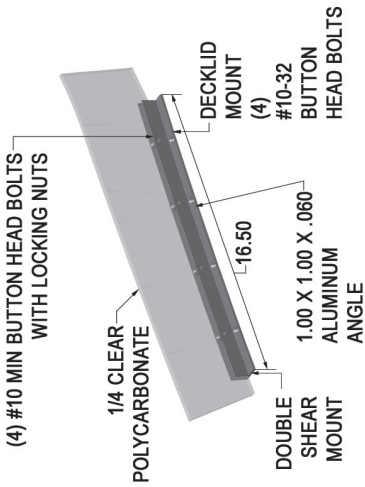
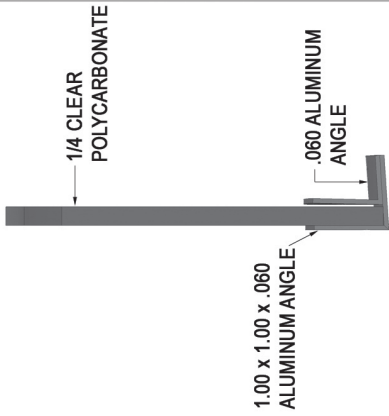

DIAGRAM #10 STATIONARY AIR DEFLECTOR MOUNTING

2015 REAR DECKLID STATIONARY AIR DEFLECTOR



DOUBLE SHEAR MOUNTING BRACKET



2015 STATIONARY AIR DEFLECTOR - REAR WINDOW

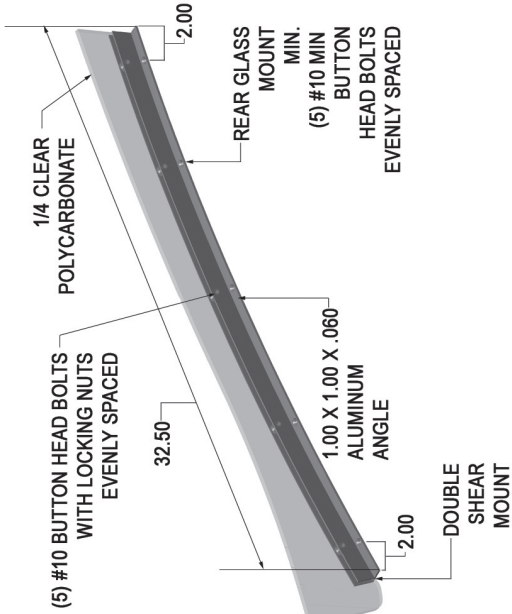

NOTES:
 VERTICAL AND HORIZONTAL BOLT HOLES ON THE DECKLID AND REAR WINDOW AIR DEFLECTOR MOUNTING BRACKETS SHOULD LINE UP WITH EACH OTHER. UNLESS OTHERWISE SPECIFIED, ALL UNITS ARE INCHES.

DIAGRAM #11 REAR QUARTER PANEL REINFORCEMENT

MATERIAL:
MIN 0.090"
thick aluminum

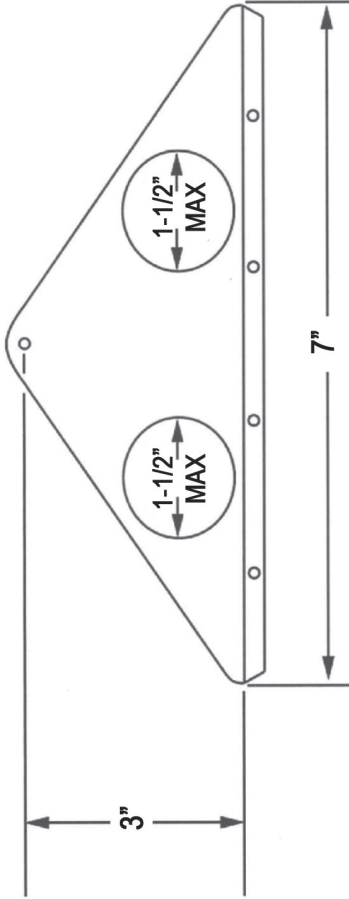

Modifications to these dimensions will not be permitted

DIAGRAM #12 - REAR RAIN/DIRT FLAP INSTALLATION

NOTES:

1. UNLESS OTHERWISE SPECIFIED, ALL UNITS ARE INCHES.
2. EACH FLAP MUST BE FASTENED TO THE FORWARD FACING SURFACE OF THE REAR CRUSH PANEL WITH A MIN. OF (4) FASTENERS WITH A BACKING PLATE FOR THE NUT PLATES. THE FASTENERS MUST BE 1/4 BOLTS WITH LARGE WASHERS.
3. THE BACKING PLATE MUST BE CONSTRUCTED OF MIN. 0.100 THICK ALUMINUM. THE BACKING PLATE IS INSTALLED ON THE INSIDE OF THE CRUSH PANEL AND MUST CAPTURE ALL THE FLAP MOUNTING FASTENERS.

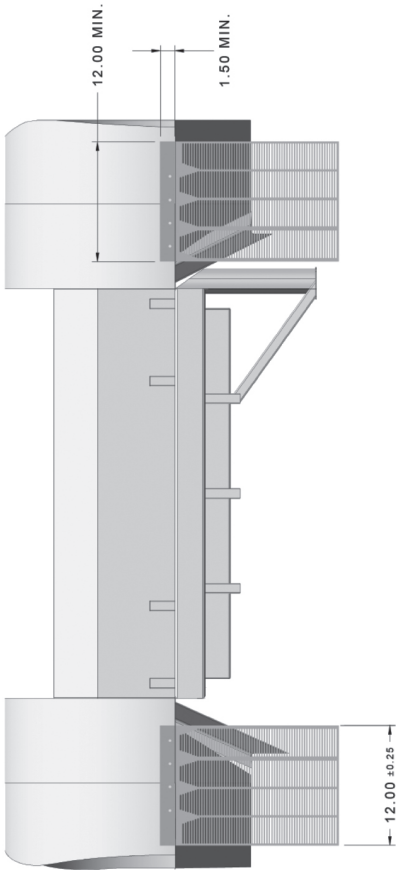
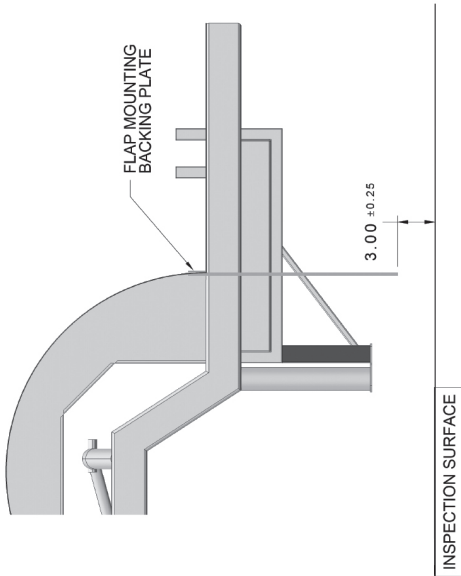

APPROVED REFUELING CAN

**APPROVED
MAX CAPACITY
12 GALLONS**

MATERIAL:

MIN 0.050 THICK ALUMINUM

NOTES: UNLESS OTHERWISE SPECIFIED,
ALL UNITS ARE INCHES.

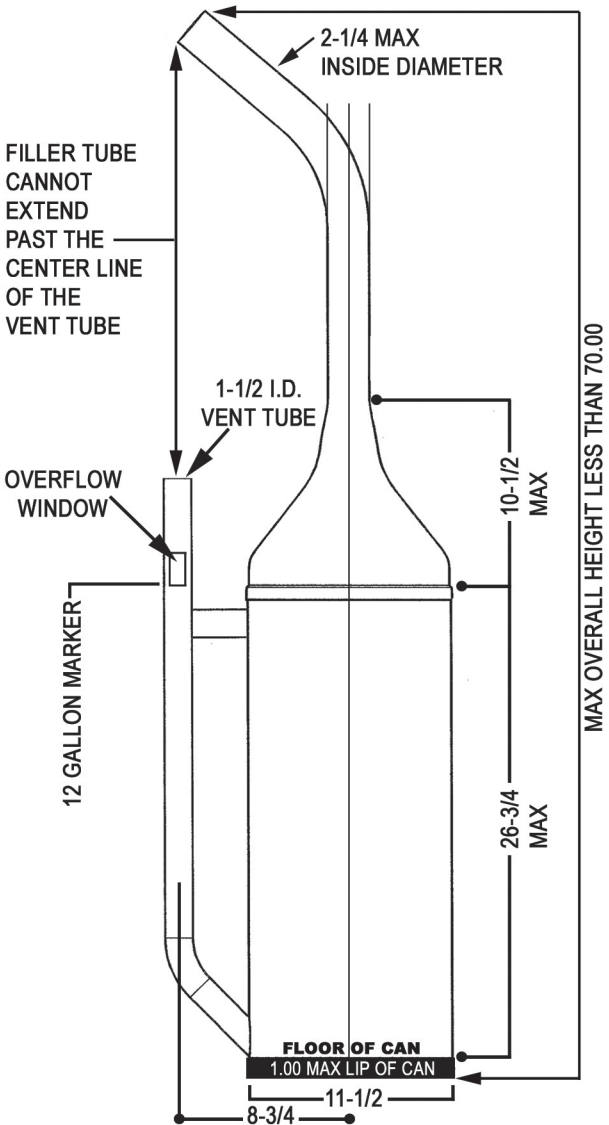

VEHICLE REQUIREMENTS INDEX

This is an alphabetical order subject index. To use this index, prefix the reference subsection number for given subject with the appropriate section number given below to obtain the complete subsection number. For example, to look up "Air Cleaner simply add number "20C to the referenced subsection number"-5.12.1" to obtain complete subsection number 20C-5.12.1.

<u>Index Topic</u>	<u>Subsection</u>
Accessories	-6.7
Advertising (Identification and Marking)	-3.11
A-Frames	-12.4
Air Cleaner/Air Filter.	-5.12.1
Air Dam (Front).	-3.1
Air Deflector (Roof Flap)	-3.8 H
Air Ducts (Side Window)	-3.2.3B & D
Air Intake.	-5.12.2
Alternator	-6.3
Auxiliary On/Off Switch.	-6.1.6A
Ball Joints.	-12.4K
Battery	-6.5
Battery Box	-6.5
Bell Housing.	-10.3
Body Dimensions	-2.1
Body Height Requirements	-12.8.1
Body, Detailed Requirements	-3
Body, General Requirements.	-2
Body Templates.	3.12.1
Bore and Stroke.	-5.4
Brakes and Brake Cooling	-14
Brake Components	-14.1
Brake Cooling	-14.2
Brake Fluid Re-circulating Device	-14.2B
Brake Pedal	-14.1J
Brake Pressure Proportioning System	-14.1L
Broadcast Telemetry System.	-6.7B
Bumper Covers	-2.1F;-2.1G;-3.10
Camera (In Vehicle)	-6.7
Camshaft	-5.8.1
Carburetor/Throttle Body	-5.10
Carburetor/Throttle Body Eligibility	-5.10.1
Carburetor/Throttle Body Gaskets	-5.10.2
Carburetor/Throttle Body Fuel Filter	-5.10.4
Carburetor/Throttle Body Restrictor	-5.10.3
Carburetor/Throttle Body Spacer	-5.10.2
Clutch	-10.1
Coil Spring Inserts	-12.1A
Coil Springs	-12.1
Competition Models	-20.1
Compression Ratio	-5.4
Computerized Systems	-6.1
Cowl Air Induction (Cold Air Box).	-5.12.2
Crankshaft	-5.7.1
Crush Panels	-2.1,-3.4.6
Cylinder Head Eligibility	-5.6.1
Cylinder Head External Changes.	-5.6.2
Cylinder Head Internal Changes	-5.6.3
Cylinder Head, Detailed	-5.6
Cylinder Head, General.	-4.2.B
Dash Inspection Panel	-3.3A

Dash Panel	-3.3
Decals	-3.11
Doors	-3.5
Drive Shaft	-10.5
Drive Train	-10
Electrical System	-6
Engine Block Eligibility	-5.5.1
Engine Block Internal Changes	-5.5.2
Engine Blocks	-5.5
Engine Characteristics, General	-4.2
Engine Cooling System	-7
Engine (Displacement)	-5.4
Engine Eligibility	-4.1
Engine Ground Clearance	-5.2
Engine Location	-5.1
Engine Lubrication	-8
Engine Mounts	-5.3
Engine, Detailed Requirements	-5
Engine, General requirements	-4
Exhaust Header	-9.1
Exhaust Pipes	-9.2
Exhaust System	-9
Fan	-7.2
Fan Shroud	-7.2
Fenders	-3.6
Fire Resistant Uniforms & Accessories	-17B
Firewall	-3.4.1
Floor Pan	-3.4.4
Flywheel	-10.2
Forced Air Induction	-5.11
Frame Requirements	-11.2
Frame Eligibility	-11.1
Frame Modifications	-11.2
Frames	-11
Fuel	-15
Fuel Cell	-16.1
Fuel Cell Container	-16.2
Fuel Cell Installation	-16.3
Fuel Cell Vent	-16.4.2
Fuel Definition	-15.1
Fuel Filler Cans	-16.6
Fuel Filler	-16.4.1
Fuel Lines	-16.5.1
Fuel Pump	-16.5.2
Fuel Specifications	-15.2
Fuel Systems	-16
Grilles	-3.7
Ground Clearance Requirements	-12.8.2
Gussets (Roll Bars)	-18.C
Harmonic Balancer	-5.7.2
Headlights	-3.2.4
Head & Neck Restraint Devices	-17.1B
Headrest	-17.3F
Headrest Supports & Nets	-17.3DH
Helmets	-17.1A
Hinged Air Deflectors (Roof Flaps)	-3.8H
Hinged Trap Doors (Hood Flaps)	-3.8E
Hood Cables	-3.8D
Hoods	-3.8
Hubs	-12.5

Identification and Marking	-3.11
Ignition System	-6.1
Ilmor Engine	-4.1B
Intake Manifold	-5.9
Lights	-3.2
Lug Bolts and Nuts	-10.7
Mirrors	-3.2
Oil	-8.1
Oil Coolers	-5.5.4
Oil Filters.	-8.3
Oil Pans	-5.5.4
Oil Pressure	-8.2
Oiling System.	-8.4
Onboard Fire Suppression System	-17C
Padding (Roll Bar)	-18F
Panhard Bar (Track Bar)	-12I
Parking Lights	-3.2.4
Personal Safety Equipment	-17
Pistons	-5.5.3
Pitman Arm	-13.1
Quarter Panels.	-3.6
Radar Guns	-6.7
Radiator	-7.4
Radiator Ducts.	-7.3
Radio.	-6.8
Radio Antenna	-6.8
Rear Axle	-10.6
Rear Deck Lids	-3.9
Rear Deck Lid Cables	-3.9F
Rear Firewall.	-3.4.5
Rear View Mirrors	-3.2.5
Rear Window	-3.2.2
Remote Control Device.	-12.9
Remote Lap Timing Devices	-6.7
Restrictor Plates (Carburetor/Throttle Body)	-5.10.3
Rocker Arms	-5.8.3
Rocker Panels	-3.6
Rocker Panel Extensions	-3.6
Rods	-5.5.3
Roll Bars	-18
Roof	-3.8
Roof Flap (Hinged Air Deflector)	-3.8H
Roof Hatch.	-3.8
Roof Strips	-3.8G
Rookie Stripes	-3.11
Seats & Seat Mounts.	-17.3
Seat Belts	-17.2
Shifter Boots	-10.4
Shock Absorbers.	-12.3
Shoulder Harness	-17.2
Side Windows	-3.2.3
Spark Plugs	-6.2
Spec Engine	-4.1C
Speed Sensing Devices	-6.7
Spindles	-12.5
Spoilers, Front Air Dam.	-3.1
Spoilers, Rear	-3.1.1
Starter.	-6.4
Steering Components.	-13
Steering Linkage	-13

Steering Shaft	-13
Steering Wheel	-13
Streamlining	-2.1H
Sub-Frame (Front & Rear).	-11.2
Suction Ducts	-3.2.3C
Suspension	-12
Sway Bars (Anti-Roll Bars)	-12.2
Switch Locations.	-6.6
Tire Usage Rules	-10.8.4
Tires	-10.8
Tires, ARCA-Approved	-10.8.2
Tires, ARCA Measurement Procedure	-10.8.3
Tires, Physical Requirements.	-10.8.1
Traction Control Devices	-6.7
Transmission	-10.4
Tread Width Requirements.	-12.6
Valves	-5.6.1
Valve Lifters	-5.8.2
Vehicle Bodies	-2.1
Vehicle Height Adjustment Devices.	-12.9
Vehicle Numbers	-3.11
Water Pump	-7.1
Weight, Added.	-2.3
Weight, Overall.	2.2
Wheel Bearings	-12.5
Wheel Spacers.	12.6C
Wheelbase Requirements	12.7
Wheels	-10.7
Windows.	-3.2
Window Net	- 17.4
Windshield	-3.2.1

NOTES

NOTES

NOTES